

THIS DRAWING IS UNPUBLISHED. RELEASED FOR PUBLICATION
 © COPYRIGHT - By - ALL RIGHTS RESERVED.

REVISIONS					
P	LTR	DESCRIPTION	DATE	DWN	APVD
T		REVISED PER ECO-110-012870	28APR11	HMR	DR
T1		REVISED PER ECO-17-008808	28FEB2018	RS	DR

AMP
WIRE RANGE

22-16 AWG
SOLID OR STRANDED

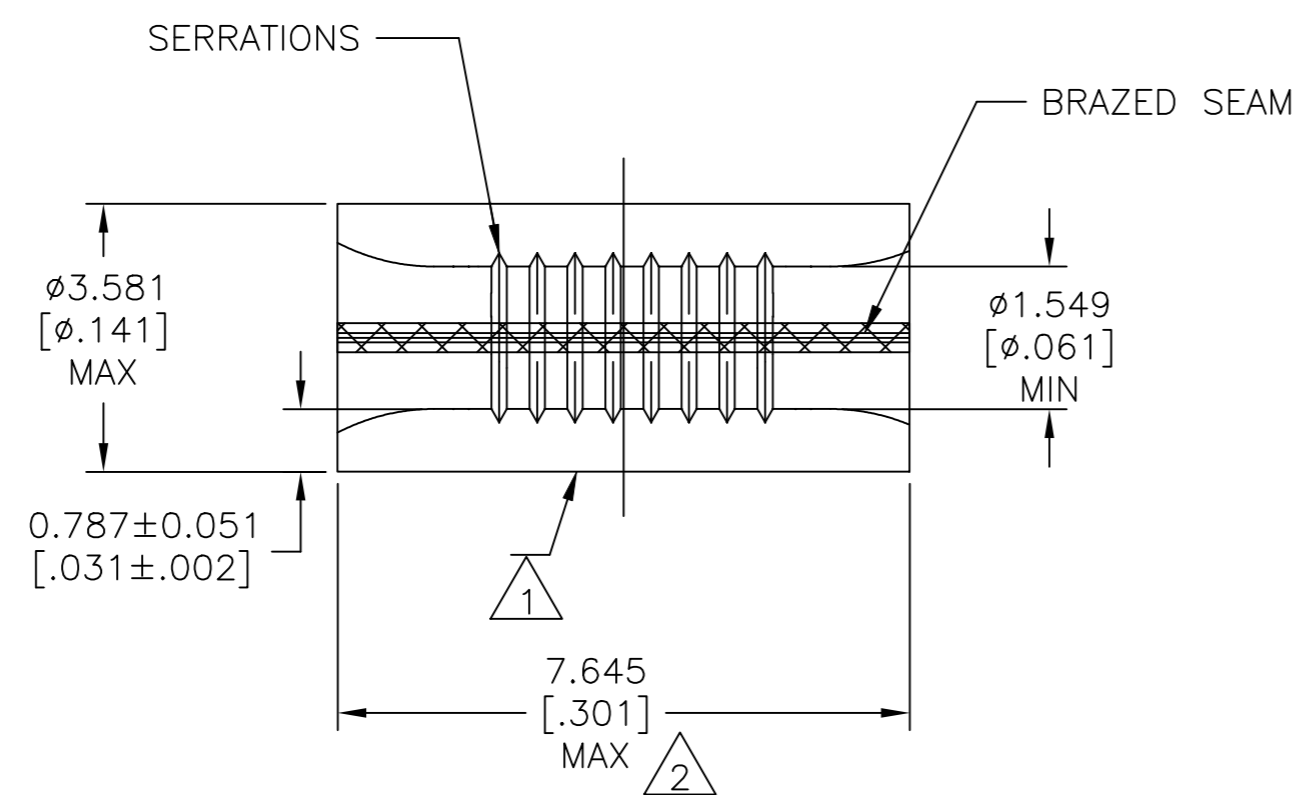

- 1 STAMP AMP 22-18* APPROX AS SHOWN 22-16 SPLICES ARE STAMPED 22-18 IN ACCORDANCE WITH MILITARY SPEC SAE AS7928 COMMERCIAL WIRE RANGE IS 22-16
- 2 MAXIMUM LENGTH DOES NOT INCLUDE MANUFACTURING TABS.
- 3 GOLD PLATE 0.00127 [.000050] MIN EXT THK PER ASTM B 488 TYPE 1, CODE C OVER NICKEL PLATE 0.00127 [.000050] MIN EXT THK PER SAE AMS QQ-N-290. OVER Cu FLASH PER SAE AMS 2418.
- 4 CSA CERTIFIED LR7189, 22-16 AWG SOLID OR STRANDED
- 5 UL LISTED E13288, 22-16 AWG SOLID OR STRANDED.
- 6 MATERIAL: COPPER PER ASTM B-152 ANNEALED
- 7 0.00254 [.000100] MIN EXT THK TIN PLATE PER ASTM B-545
- 8 0.00254 [.000100] MIN EXT THK TIN-LEAD (60/40) PLATE PER SAE-AMS-P-81728

170°C [338°F]	4 5	100	LOOSE PIECE, BOX	7 8-34130-1
170°C [338°F]	--	1000	LOOSE PIECE	8 34130-4
260°C [500°F]	--	1000	LOOSE PIECE	3 34130-3
170°C [338°F]	4 5	1000	LOOSE PIECE	7 34130
MAX TEMP	APPROVALS	QTY	PACKAGE TYPE	PART NO

AMP INCORPORATED
CUSTOMER SERVICE SYSTEMS

MAX RECOMMENDED OPERATING TEMPERATURE:
SEE TABLE

VOLTAGE RATING:
N/A

CIRCULAR MIL AREA:
0.26-1.65mm² [509-3,260]
SOLID OR STRANDED

FOR ADDITIONAL PRODUCT INFORMATION OR COPIES OF DRAWINGS AND TECHNICAL DOCUMENTS
PRODUCT INFORMATION CENTER
1-800-522-6752

FOR APPLICATION TOOLING INFORMATION
TOOLING ASSISTANCE CENTER
1-800-722-1111

FOR ORDER ENTRY
1-800-526-5142

THIS DRAWING IS A CONTROLLED DOCUMENT FOR AMP INCORPORATED. IT IS SUBJECT TO CHANGE AND THE CONTROLLING ENGINEERING ORGANIZATION SHOULD BE CONTACTED FOR THE LATEST REVISION.

THIS DRAWING IS A CONTROLLED DOCUMENT.

DIMENSIONS: mm [INCHES]

TOLERANCES UNLESS OTHERWISE SPECIFIED:

0 PLC ± -
1 PLC ± -
2 PLC ± -
3 PLC ± 0.127 [.005]
4 PLC ± -
ANGLES ± -
FINISH SEE TABLE

DWN TA BRINKMAN 4-14-93
CHK DA PATTERSON 4-14-93
APVD J MECKLEY 4-14-93

NAME
SPLICE, PARALLEL, SOLISTRAND 22-16 AWG

PRODUCT SPEC UL 486 C
APPLICATION SPEC -

SIZE A2 CAGE CODE 00779 DRAWING NO C=34130 RESTRICTED TO -

MATERIAL 6 WEIGHT CUSTOMER DRAWING SCALE 10:1 SHEET 1 of 1 REV T1

STE TE Connectivity Ltd.