

THIS DRAWING IS UNPUBLISHED. RELEASED FOR PUBLICATION
 © COPYRIGHT - By - ALL RIGHTS RESERVED.

REVISIONS					
P	LTR	DESCRIPTION	DATE	DWN	APVD
J2		REVISED PER ECO-16-004223	16JUL2016	NK	MZ

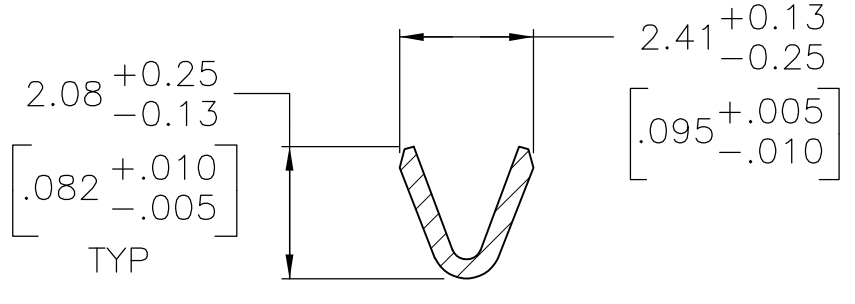
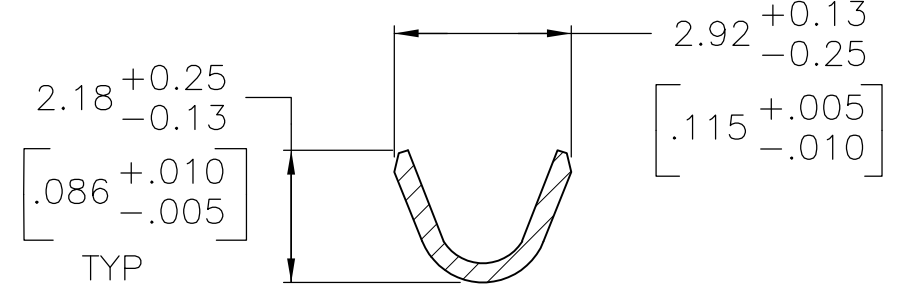
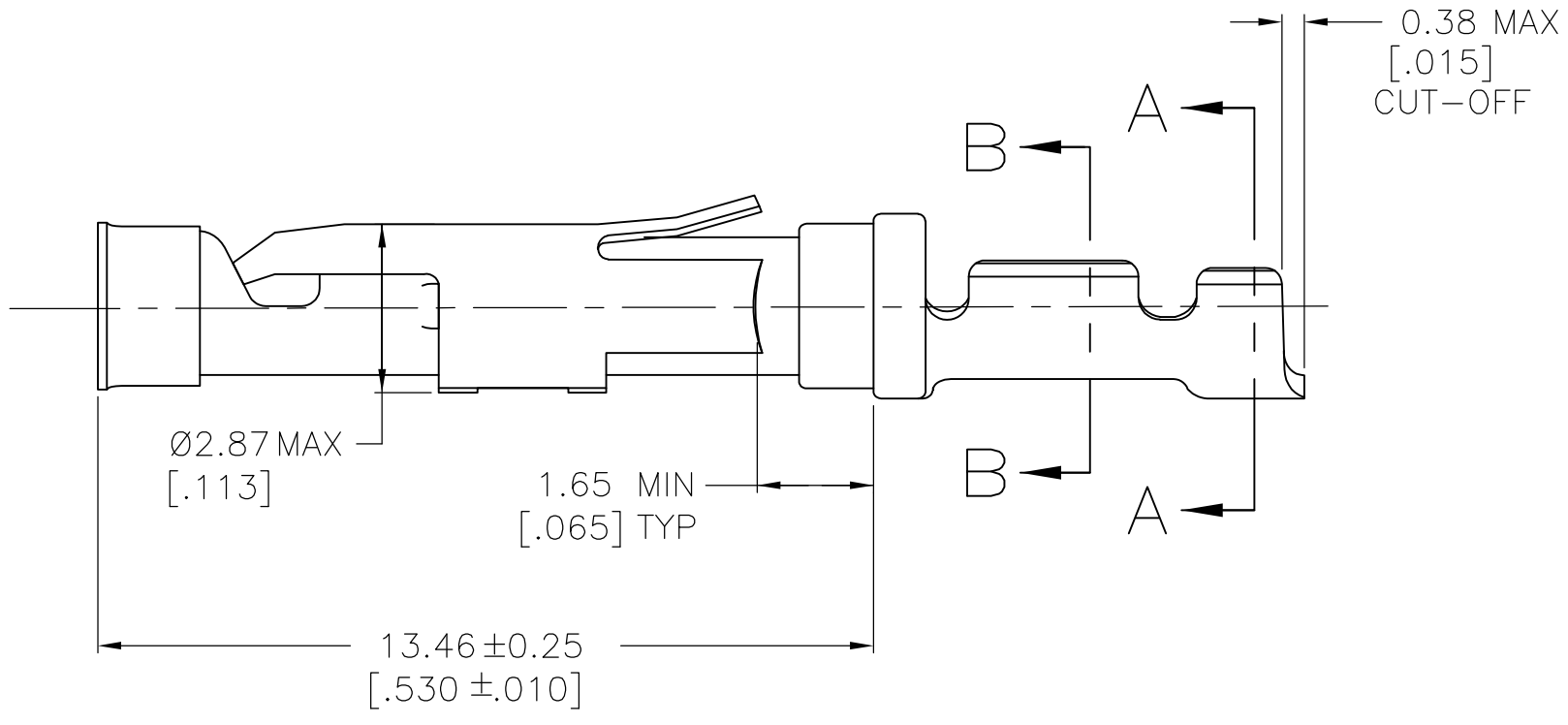
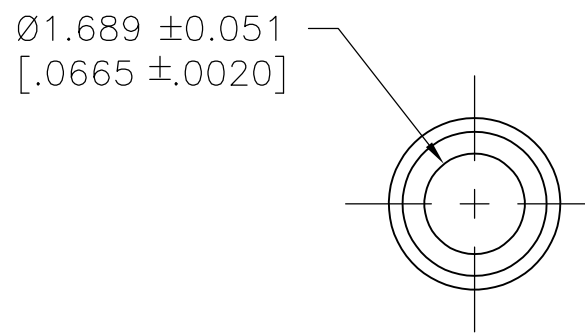
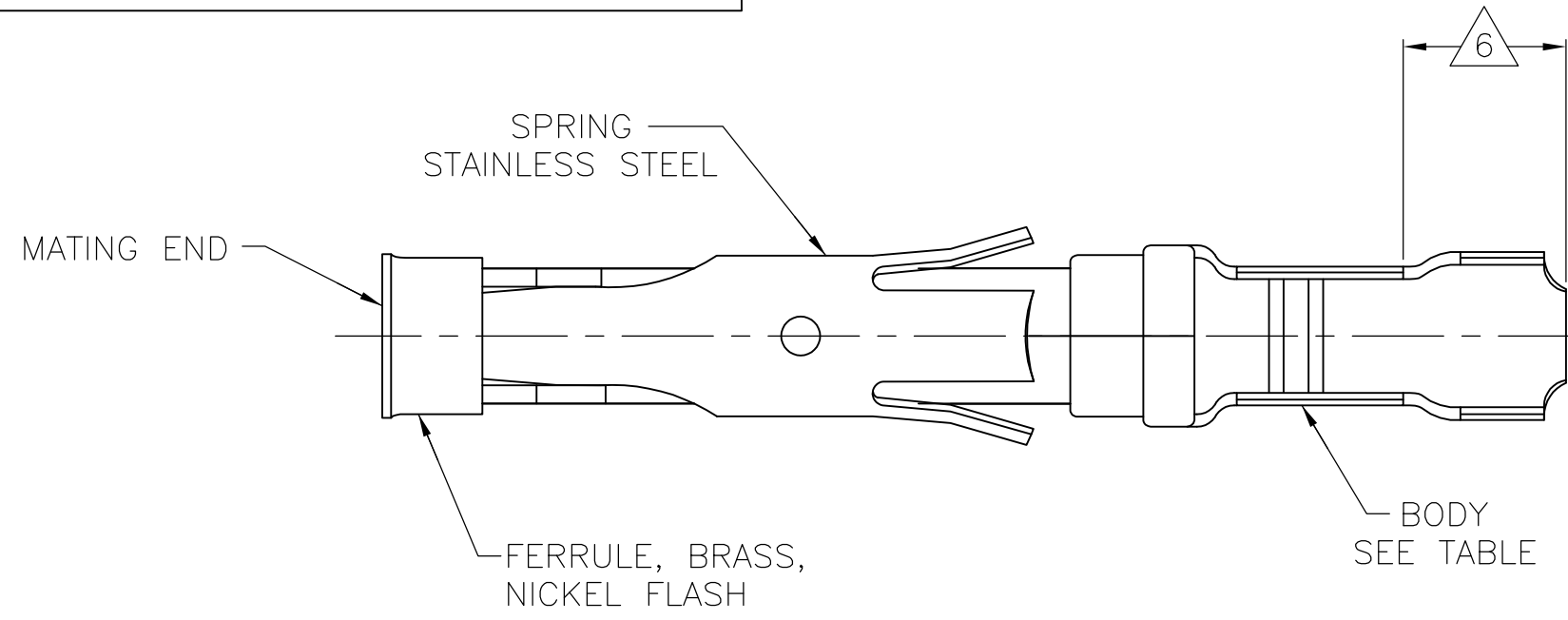

- 1 0.76µm [.000030] MIN GOLD PER MIL-G-45204 ON MATING END FOR A LENGTH OF 5.08 [.200] MIN WITH 1.27µm [.000050] MIN MATTE TIN PLATE IN WIRE CRIMP AREA, BOTH OVER 0.76µm [.000030] MIN NICKEL PER QQ-N-290.
- 2 1.27µm [.000050] MIN TIN-LEAD PER MIL-T-10727 OVER 0.76µm [.000030] MIN NICKEL PER QQ-N-290.
- 3 0.76µm [.000030] MIN GOLD PER MIL-G-45204 ON MATING END FOR A LENGTH OF 5.08 [.200] MIN WITH A UNIFORM GRADIENT TO 0.25µm [.000010] MIN GOLD PER MIL-G-45204 ON THE REMAINDER OVER 0.76µm [.000030] NICKEL PER QQ-N-290.
- 4 0.38µm [.000015] MIN GOLD PER MIL-G-45204 ON MATING END FOR A LENGTH OF 5.08 [.200] MIN WITH 1.27µm [.000050] MIN MATTE TIN PLATE IN WIRE CRIMP AREA, BOTH OVER 0.76µm [.000030] MIN NICKEL PER QQ-N-290.
- 5 1.27µm [.000050] MIN GOLD PER MIL-G-45204 ON MATING END FOR A LENGTH OF 5.08 [.200] MIN WITH GOLD FLASH ON REMAINDER OVER 1.90µm [.000075] MIN NICKEL PER QQ-N-290.
- 6 GOLD PLATING NOT REQUIRED IN THIS AREA
- 7 WIRE RANGE 24-20 AWG. INSULATION RANGE 1.02 [.040]-2.03 [.080].
- 8 0.38µm [.000015] MIN GOLD PER MIL-G-45204 ON MATING END FOR A LENGTH OF 5.08 [.200] MIN, 1.27µm [.000050] MIN TIN-LEAD PER MIL-T-10727 FOR A LENGTH OF 5.69 [.224] MIN ON OPPOSITE END, BOTH OVER 1.27µm [.000050] MIN NICKEL PER QQ-N-290 ON ENTIRE CONTACT.
- 9 1.27µm [.000050] MIN TIN PER MIL-T-10727 OVER 0.76µm [.000030] MIN NICKEL PER QQ-N-290.
- 10 OBSOLETE PARTS: OBSOLETE CIS STREAMLINING PER D.RENAUD/D.SINISI

PACKAGING TYPE	FINISH	MATERIAL	STRIP P/N REF	PART NO
SMALL PACK	9	BRASS	2-66104-9 OR 3-66104-0	2-66105-0
STANDARD	9	BRASS	2-66104-9 OR 3-66104-0	1-66105-9
SMALL PACK	1	BRASS	66104-4	1-66105-8
SMALL PACK	4	BRASS	66104-3	1-66105-7
SMALL PACK	2	BRASS	66104-2	1-66105-6
SMALL PACK	3	BRASS	66104-1	1-66105-5
STANDARD	8	BRASS	2-66104-6	1-66105-4
STANDARD	1	PHOSPHOR BRONZE	2-66104-3	1-66105-3
STANDARD	2	PHOSPHOR BRONZE	2-66104-2	1-66105-2
STANDARD	5	BRASS	1-66104-6	1-66105-0
STANDARD	1	BRASS	66104-4	66105-4
STANDARD	4	BRASS	66104-3	66105-3
STANDARD	2	BRASS	66104-2	66105-2
STANDARD	3	BRASS	66104-1	66105-1

THIS DRAWING IS A CONTROLLED DOCUMENT.

DIMENSIONS: mm [INCHES]	TOLERANCES UNLESS OTHERWISE SPECIFIED:	DWN L.SIPE 06/01/92	TE Connectivity SOCKET ASSEMBLY, LOOSE PIECE, TYPE III+
	0 PLC ± -	CHK W.LENKER 6-11-92	
	1 PLC ± -	APVD G.STEINHAUER 7-8-92	
	2 PLC ± 0.13 [.005]	PRODUCT SPEC	
MATERIAL	FINISH	WEIGHT	SIZE A2 CAGE CODE 00779 DRAWING NO C-66105 RESTRICTED TO CUSTOMER DRAWING SCALE 8:1 SHEET 1 of 1 REV J2