

## LongRange (LoRa) Transceiver

### Features

- Upto 16KM Range
- Integrated LoRa™ Modem Semtech SX1272
- Highly Efficient Integral Impedance Matching Network
- Provides Full Functionality of the RFIC:
- 157 dB maximum link budget
- +20 dBm at 100 mW constant RF output vs. V supply
- +14 dBm high efficiency PA
- Built in RF switch
- High sensitivity: down to -130 dBm
- Bullet-proof front end: IIP3 = -12.5 dBm
- 89 dB blocking immunity
- Small Form Factor: 23mm x 20mm
- Programmable bit rate up to 300 kbps
- Low RX current of 10 mA, 100nA register retention
- FSK, GFSK, MSK, GMSK, LoRa™ and OOK modulation
- Built-in bit synchronizer for clock recovery
- Preamble detection
- 127 dB Dynamic Range RSSI
- Automatic RF Sense and CAD with ultra-fast AFC
- Packet engine up to 256 bytes with CRC
- Built-in temperature sensor and low battery indicator

### RF-LAMBDA

- 915MHz “Modular” FCC Certification Pending



### Applications

- Home Automation
- RF Alarms
- Sensor networks
- Long Range Telemetry
- Meter Reading
- Irrigation Systems
- Wireless Applications
- Alarms

### Description

The RF-LAMBDA 915MHz module is an extremely high performance, cost effective radio module featuring the Semtech SX1272 LoRa™ long range providing ultra-long range, spread spectrum communication and high interference immunity within minimal current consumption.

This module including crystal, RF Changeover switch, impedance matching network and track layout provide a simple digital interface and direct antenna connection. This enables a plug in RF solution with maximum efficiency. Programming of the module is via SPI interface.

Using the RF-LAMBDA enables a fast and easy to market solution with cost effective license exempt hardware.

The RF-LAMBDA Module is CE compliant. Providing that certain procedures are followed. (please refer to application schematic later in this datasheet).

## RF-LAMBDA Pin Description

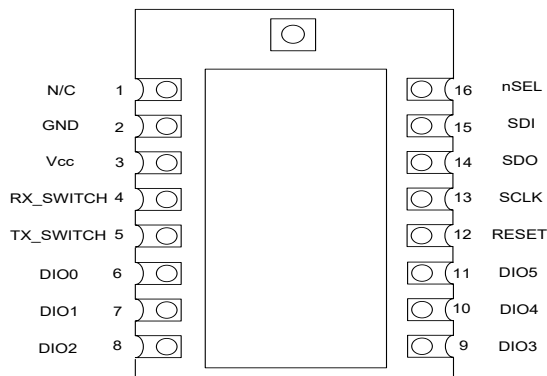

## Mechanical Dimensions

## Suggested Layout

### SMT Version

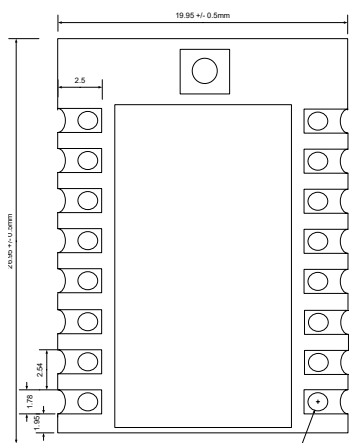

PCB Layout

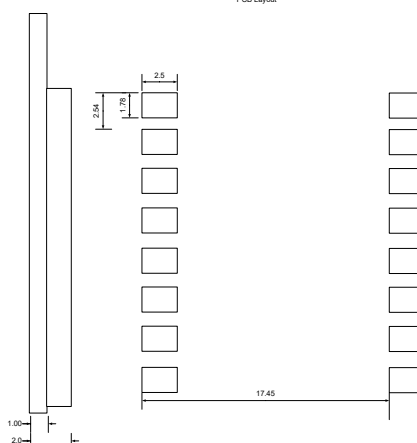

### DIP Version

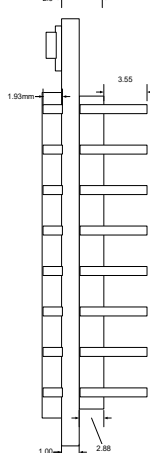
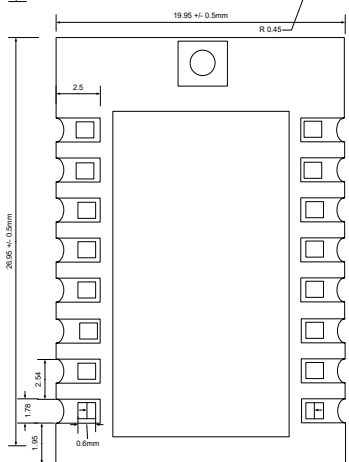

## Part Numbers

Part Number	Description	Package
LAMBDA9-SO	FM Transceiver Module, 915MHz	SMT
LAMBDA9-D	FM Transceiver Module, 915MHz	DIP

## Pin Description

PIN	Definition	Direction	Function						
1	Antenna	In/Out	Antenna pin connection. Keep short (50ohms Impedance)						
2	GND	-	Ground connection						
3	Vcc	In	Power connection						
4	RX_SWITCH	In	Enable RX RF Path Active High <table border="1" data-bbox="954 631 1337 734"> <tr> <td></td> <td>TX PIN5</td> <td>RX PIN4</td> </tr> <tr> <td>RX Mode</td> <td>0</td> <td>1</td> </tr> </table>		TX PIN5	RX PIN4	RX Mode	0	1
	TX PIN5	RX PIN4							
RX Mode	0	1							
5	TX_SWITCH	In	Enable TX RF Path Active High <table border="1" data-bbox="954 779 1337 882"> <tr> <td></td> <td>TX PIN5</td> <td>RX PIN4</td> </tr> <tr> <td>TX Mode</td> <td>1</td> <td>0</td> </tr> </table>		TX PIN5	RX PIN4	TX Mode	1	0
	TX PIN5	RX PIN4							
TX Mode	1	0							
6	DIO0	In/Out	Digital I/O software configured						
7	DIO1	In/Out	Digital I/O software configured						
8	DIO2	In/Out	Digital I/O software configured						
9	DIO3	In/Out	Digital I/O Software configured						
10	DIO4	In/Out	Digital I/O software configured						
11	DIO5	In/Out	Digital I/O software configured						
12	RESET	In	Reset Trigger Input						
13	Serial Clock	In	SPI Serial Clock Input						
14	Serial Data Out	Out	SPI Serial Data Output						
15	Serial Data In	In	SPI Serial Data Input						
16	nSEL	In	Device Select Active Low						

## RF-LAMBDA

The RF-LAMBDA module is available at 915MHz.(for our 868 alternative please see our part RF-LORA-868)  
 RF-LAMBDA module is CE Compliant and meets the requirements for FCC part 15. This enables the end product that  
 RF-LAMBDA-915 is incorporated into to automatically use the RF-LAMBDA module FCC certificate without further  
 testing.

## Block Diagram

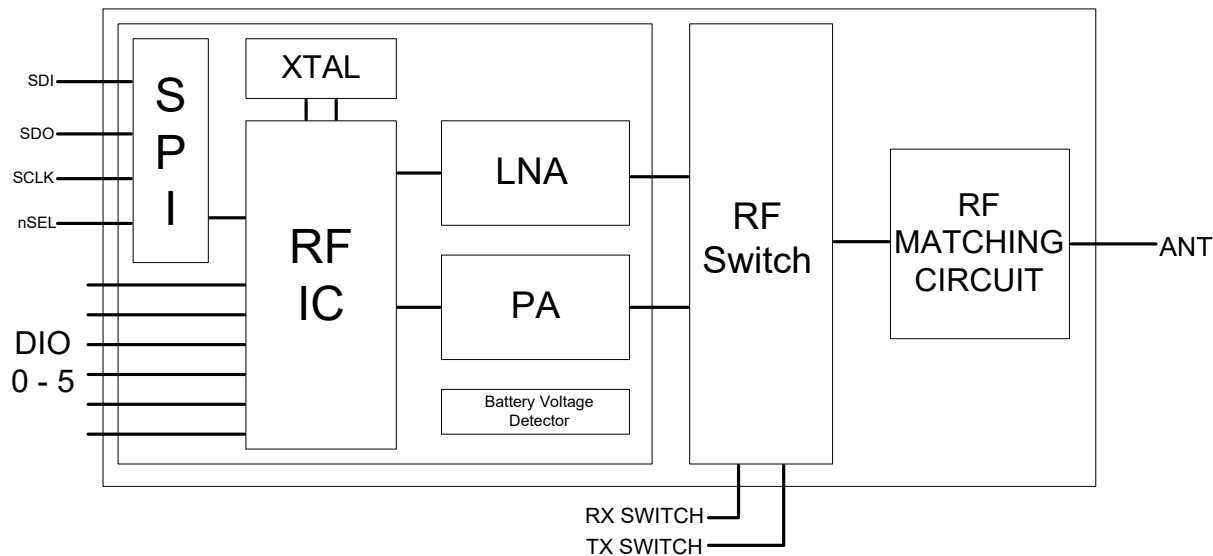

## Application Resources

The RF-LAMBDA is a ready to use application of the Semtech SX1272. Access to the programming and configuration of Semtech 1272 Transceiver are via the modules interface SPI line.

The RF-LAMBDA has been developed with Semtech to provide a low cost platform application of the 1272 transceiver. This offers optimal design realisation and easy integration within the end application. The most important aspect of any RF Module is to maximise the performance of the transceiver at the external module pads.

In particular the impedance matching network which is the most sensitive section of the RF module design. In order to maximise signal propagation to the external pad of the module, a specific layout is required which is not (usually) the smallest physical size (beware of small RF modules!). Many RF Module manufacturers simply reproduce the IC manufacturers data characteristics where in practice the Module RF performance is considerably lower.

To ensure that the latest details in programming this device are offered, we have not included the 1272s programming information in this document.

Programming, configuration and further resource data is available from Semtech at the below links:

[SX1272 Datasheet](#)

[LoRa Calculator: fast evaluation of link budget, time on air and energy consumption](#)

<http://www.semtech.com/images/datasheet/etsi-compliance-sx1272-LoRa-modem.pdf>

[Packet Error Rate Firmware User Guide](#)

[LoRa Modem Designer's Guide](#)

## Application schematic Interfacing a PIC™ Micro Controller

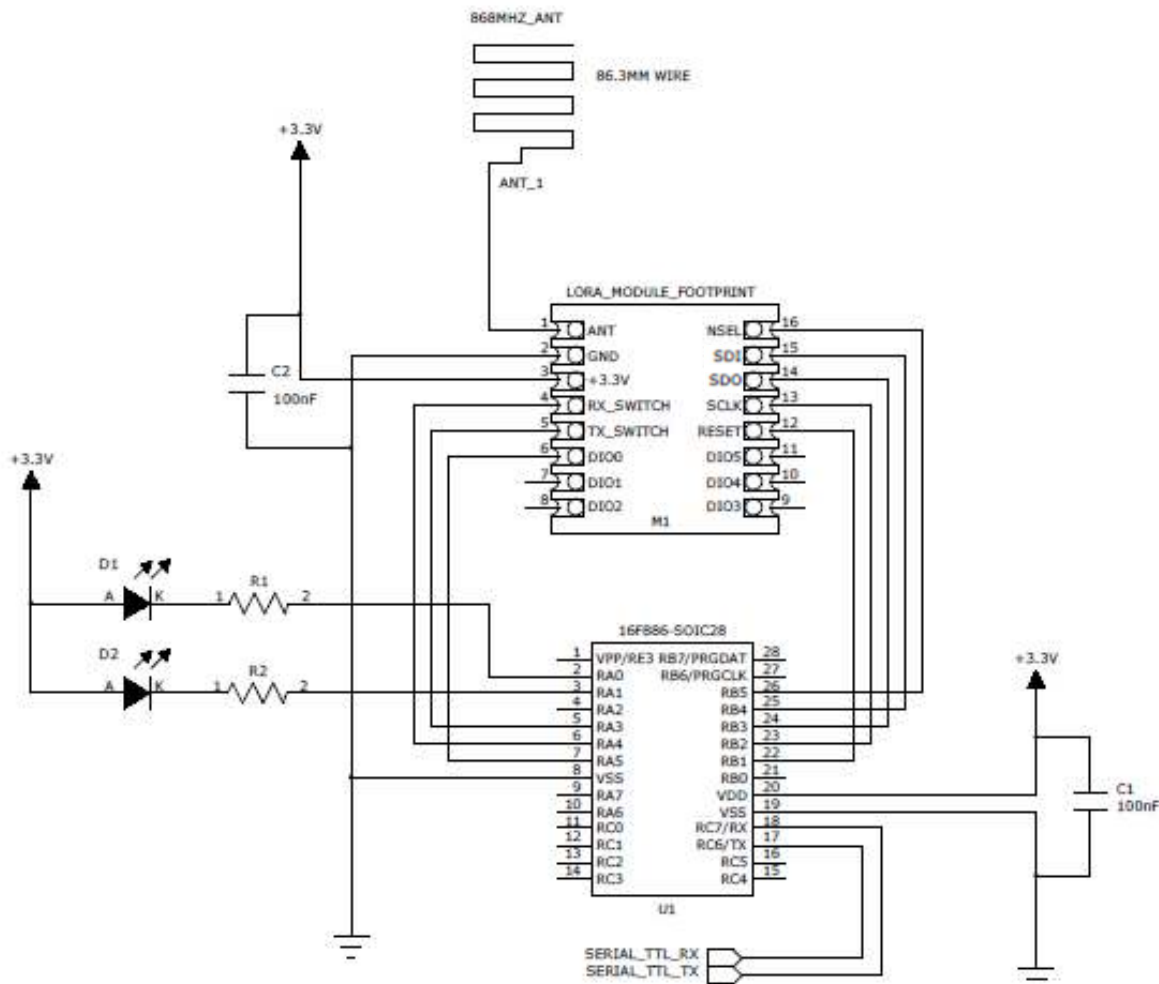

The above schematic shows an easy interface to a PIC Microcontroller

This is the same application circuit that we used for range testing (please see our range test information later in the document).

We also have application source code available for download on our website. This configures the RF LoRa Module for maximum range.

### Walk Test application

Also available is the source code used to carry out a simple range test.

In order to use this two application boards are required, one acts as a beacon transmitter, the other as the beacon receiver. The TX board will illuminate the GREEN LED when transmitting and the Receiver will illuminate the RED LED when RECEIVING

The Transmitter board transmits an RF beacon every second (Green LED flashes to indicate transmission).

This enables a one man range test, by placing either board in a fixed location and monitoring the beacon signals.

## Electrical Specifications

### Absolute Maximums

Symbol	Parameter	Minimum	Maximum	Unit
$V_{dd}$	Positive power supply	-0.3	+3.9	V
$V_{in}$	Voltage on Digital Inputs	-0.3	$V_{dd}+0.3$	V
$V_{in}$	Voltage on Analogue Inputs	-0.3	$V_{dd}+0.3$	V
RX	Max Rx input power		+10	dBm
$T_{op}$	Operating temperature	-40	+85	°C
$T_{st}$	Storage temperature	-55	115	°C

### Recommended Operating Conditions

Symbol	Parameter	Minimum	Maximum	Unit
$V_{dd}$	Positive power supply	2.2	3.7	V
$T_{op}$	Working temperature	0	55	°C

### DC Characteristics

Parameter	Symbol	Test Condition	Min	Typ	Max	Unit
Supply Voltage Range	$V_{DD}$		1.8	3.3	3.6	V
Power Saving Modes	$I_{Shutdown}$	RC oscillator, main digital regulator, and low power digital regulator OFF.	—	30	—	nA
	$I_{Standby}$	Register values maintained.	—	50	—	nA
	$I_{Ready}$	Crystal Oscillator and Main Digital Regulator ON, all other blocks OFF.	—	2	—	mA
	ISPI Active	SPI active state		1.35		mA
TUNE Mode Current	$I_{Tune\_RX}$	RX Tune	—	6.5	—	mA
	$I_{Tune\_TX}$	TX Tune	—	6.9	—	mA
RX Mode Current	$I_{RX}$		—	10	—	mA
TX Mode Current	$I_{TX}$	RFOP = +20dBm on PA Boost RFOP = +17dBm on PA Boost RFOP = +13dBm on PA Boost RFOP = + 7dBm on PA Boost	—	125 90 28 18		mA

## Power Consumption FSK Modulation

The table below gives power consumptions figures based on the following parameters:

VBAT1 = VBAT2 = Vcc = 3.3V

Temp= 25degC

Fxosc=32MHz, Frf=915MHz, Pout= +13dBm.

2 level FSK modulation without pre-filtering, FDA=5KHz, Bit Rate=4.8kbps

Symbol	Description	Conditions	Typ	Max	Unit
IDDSL	Supply Current Sleep Mode		0.1	1	uA
IDDIDLE	Supply Current Idle Mode	RC Oscillator enabled	1.5		uA
IDDST	Supply Current Standby Mode	XTAL Oscillator enabled	1.4	1.6	mA
IDDFS	Supply Current Synthesizer Mode	FSRx	4.5		mA
IDDR	Supply Current Receive Mode	LnaBoost off LnaBoost on	10.5 11.2		mA
IDDT	Supply Current Transmit Mode	RFOP=+20dBm on PA_BOOST RFOP=+20dBm on PA_BOOST	125 90 28 18		mA

## Power Consumption LORA Modulation

The table below gives power consumption figures based on the following parameters:

Vcc = 3.3V

Temp= 25degC

Fxosc=32MHz, Frf=915MHz,, Bandwidth = 125KHz, Spreading Factor = 12, Error Correction = 4/6

Packet Error Rate = 1% with CRC on Payload enabled

Pout= +13dBm.

Payload length = 10bytes, Preamble =12 symbols (programmed register Preamble length = 8)

Symbol	Description	Conditions	Typ	Max	Unit
IDDR_L	Supply current in receiver LoRa Mode	LnaBoost off, BW=125KHz	9.7		mA
		LnaBoost off, BW=250KHz	10.5		
		LnaBoost off, BW=500KHz	12		
		LnaBoost on, BW=125KHz	10.8		mA
LnaBoost on, BW=250KHz	11.6				
LnaBoost on, BW=500KHz	13				
IDDT_H_L	Supply Current Transmitter Mode	Using PA_BOOST pin RFOP=17dBm	90		mA

**PLEASE NOTE:** RFO is not connected on the RF-LAMBDA the RF out is connected through PA-BOOST only.

## Range Test Notes

Transmitter and Receiver boards were built using simple Vero board and a PIC microcontroller (16F886). The transmitter sent a beacon signal at 1 second intervals. The receiver acknowledges this signal back to the transmitter.

A simple piece of wire was used as antenna for both transmitter and receiver.

This test was designed to represent a real life application. It is often difficult to design an application with all RF features to an optimum potential i.e. the antenna was not 100% ideal as there was no antenna ground plane, and the mother-board was rudimentary,

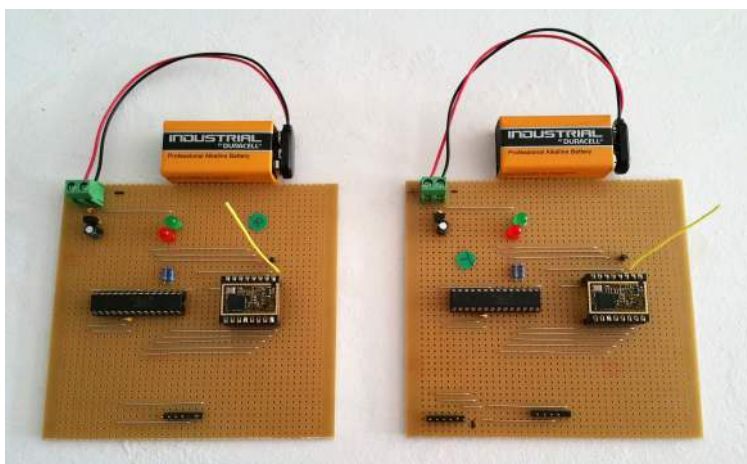

Our Range Testing was conducted on Brighton to Shoreham Seafont providing an open Line of Sight Test.

1. The Transmitter was mounted on a plastic wheelie bin 4ft from the ground.
2. The Receiver was carried on the dashboard of a vehicle ( 5ft above ground) along the seafont. Line of sight was not achieved until the receiver was at least 9km distance
3. As the receiver travelled away from the transmitter Line of sight was lost . A Reliable signal was observed to about 3K range, thereafter the signal became intermittent. When the Transmitter and Receiver regained Line of sight a reliable signal was again observed. This continued for the available distance (about 12KM) at which point the terrain prevented further testing. At the longest available range the signal was 100% reliable.

### Test conditions

- $T_A = +25\text{ }^\circ\text{C}$
- $V_{DD} = +3.3\text{ Vdc}$
- Dry, Broken Sunshine, Relative Humidity 45%
- RF input and output levels can typically be achieved at the antenna port after filtering components.

### Conclusion

The product performed as expected. Unfortunately we ran out of land to test a LOS beyond 12Km ,so the maximum range is further than tested here.

It is also clear that the product performs considerably better when in LOS.



## Range Test Results (Line of Sight)

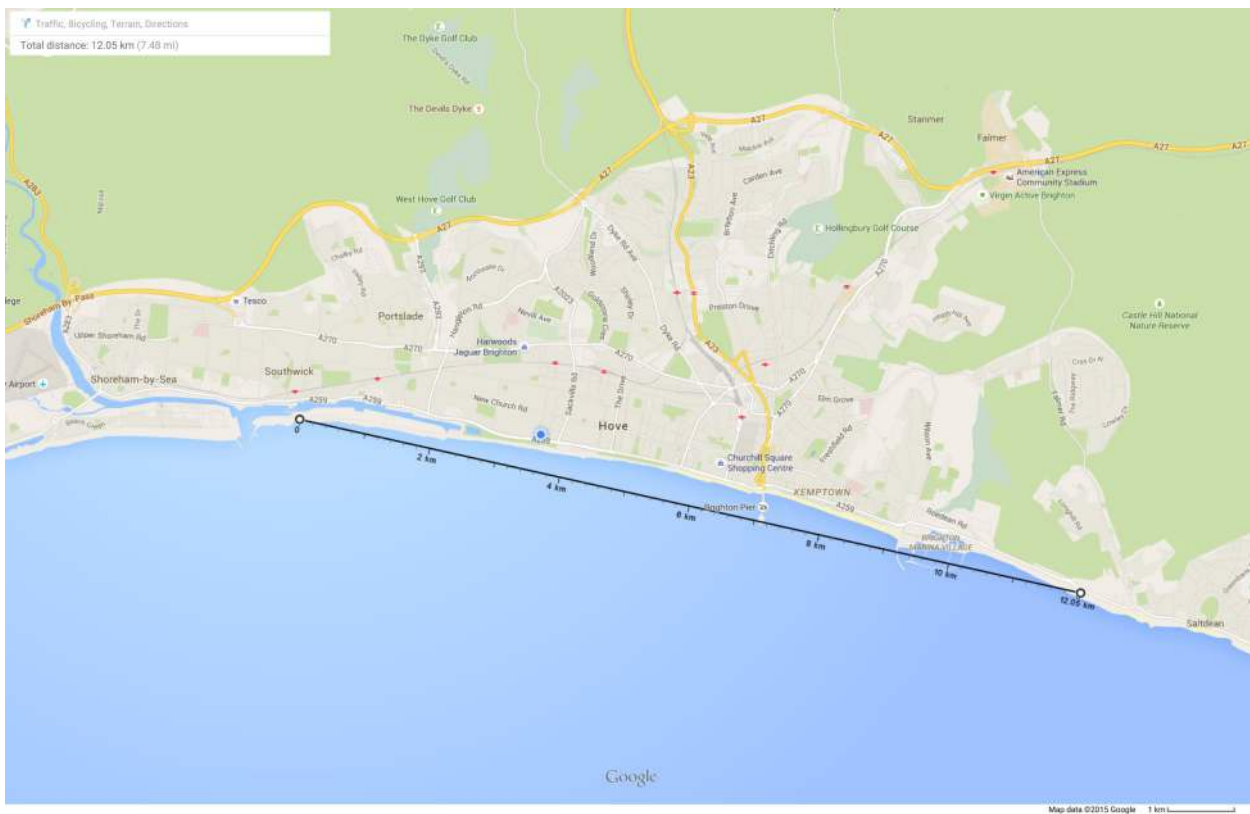

## Range Test Results (Non Line of Sight)

This is subjective as the buildings were random!

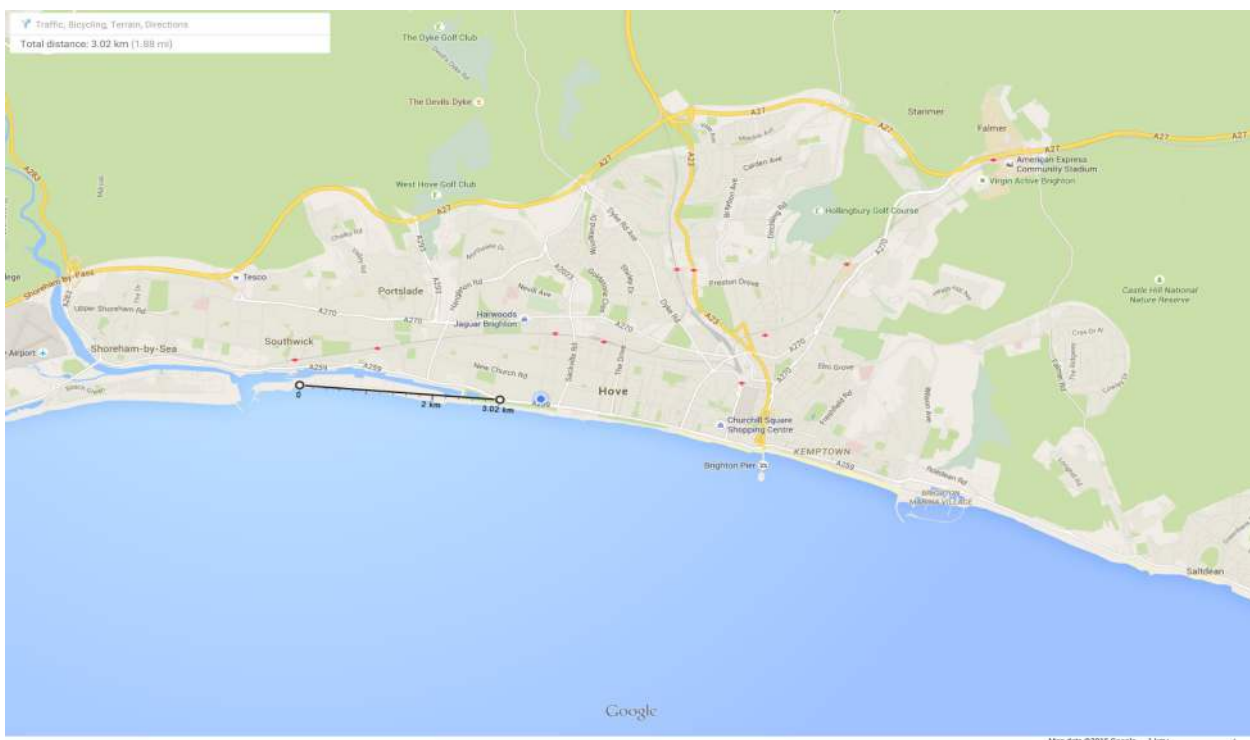

## RF LoRa module re-flow guide

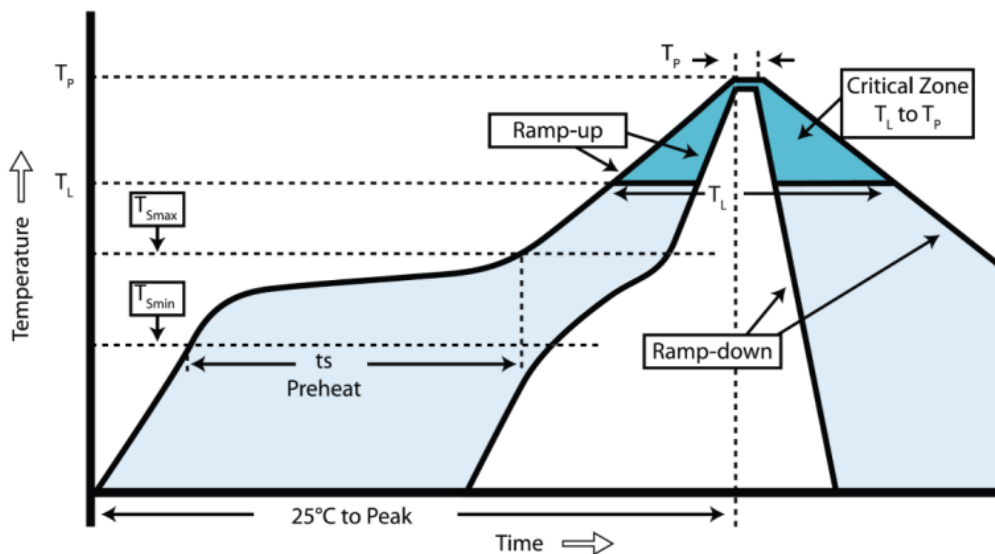

Profile feature	Value (lead free)
Ramp up rate	3°C /s
Pre-heat Temperature	
- Temperature Min ( $T_{smin}$ )	150°C
- Temperature Max ( $T_{smax}$ )	200°C
- Pre-heat time	60-100s
Peak Temperature ( $T_p$ )	240°C
Time at $T_p$	10-20sec
Ramp down rate	6°C/s
Time from 25°C to peak	8 mins max.

### RF Solutions Ltd. Recycling Notice

Meets the following EC Directives:

#### DO NOT

Discard with normal waste, please recycle.

### ROHS Directive 2002/95/EC

Specifies certain limits for hazardous substances.



### WEEE Directive 2002/96/EC

Waste electrical & electronic equipment. must be disposed of through a licensed point. RF Solutions Ltd., fulfills its WEEE membership of an approved compliance



This product WEEE collection obligations by scheme.

#### Disclaimer:

Whilst the information in this document is believed to be correct at the time of issue, RF Solutions Ltd does not accept any liability whatsoever for its accuracy, adequacy or completeness. No express or implied warranty or representation is given relating to the information contained in this document. RF Solutions Ltd reserves the right to make changes and improvements to the product(s) described herein without notice. Buyers and other users should determine for themselves the suitability of any such information or products for their own particular requirements or specification(s). RF Solutions Ltd shall not be liable for any loss or damage caused as a result of user's own determination of how to deploy or use RF Solutions Ltd's products. Use of RF Solutions Ltd products or components in life support and/or safety applications is not authorised except with express written approval. No licences are created, implicitly or otherwise, under any of RF Solutions Ltd's intellectual property rights. Liability for loss or damage resulting or caused by reliance on the information contained herein or from the use of the product (including liability resulting from negligence or where RF Solutions Ltd was aware of the possibility of such loss or damage arising) is excluded. This will not operate to limit or restrict RF Solutions Ltd's liability for death or personal injury resulting from its negligence.