

# .050" × .050" CF Card Header

Type I, Surface Mount

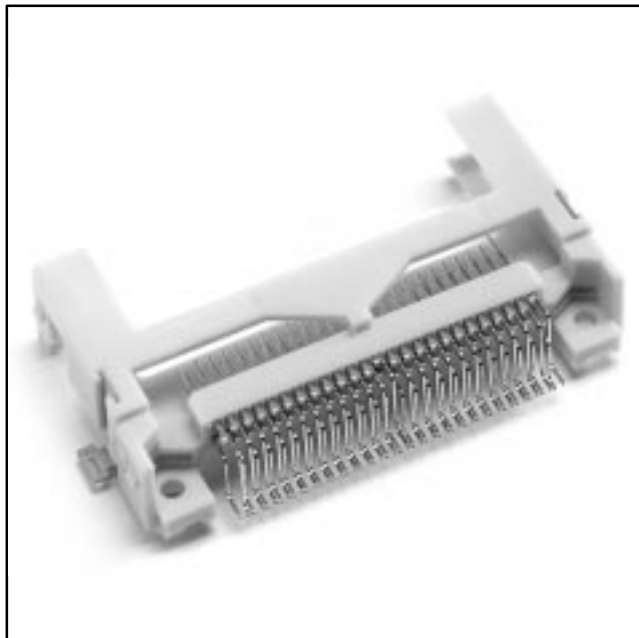

- Single row solder tails — 0.635 mm spacing
- Board component clearance — 1.64 mm standoff
- Ejector option — easy removal of CF Card from right angle header
- Meets CFA standards — known reliability
- Retainer Clip option — stability for mobile or high vibration applications

Date Modified: August 2, 2001

TS-0662-17  
Sheet 1 of 4

14

---

## Physical

### Insulation

Material: Liquid Crystal Polyester (LCP)  
Flammability: UL 94V-0  
Color: Beige

### Contact

Material: Copper Alloy

### Plating

Underplate: 100  $\mu$ " [ 2.54  $\mu$ m ] Nickel — QQ-N-290, Class 2  
Wiping Area: Gold Flash over 80/20 Palladium Nickel  
Solder Tails: 50  $\mu$ " [ 1.27  $\mu$ m ] 85/15 Tin Lead — MIL-P-81728

---

## Electrical

**Current Rating:** .5 A

**Insulation Resistance:**  $>1 \times 10^9 \Omega$  at 500 Vdc  
 $>1 \times 10^8 \Omega$  at 500 Vdc after Environmental Conditioning

**Withstanding Voltage:** 500 Vrms at Sea Level

---

## Environmental

**Temperature Rating:**  $-55^\circ\text{C}$  to  $+85^\circ\text{C}$

**Process Rating:** Maximum  $235^\circ\text{C}$ , with 90 seconds over  $215^\circ\text{C}$

UL File No.: E68080

---

### 3M Interconnect Solutions Division

6801 River Place Blvd.  
Austin, TX 78726-9000

For technical, sales or ordering information call  
**800-225-5373**

# .050" × .050" CF Card Header Type I, Surface Mount

Pin Type	Interface Dim A	Pin No.
detect	3.50 [ .138 ]	25, 26
general	4.25 [ .167 ]	all other pins
power	5.00 [ .197 ]	1, 13, 38 & 50

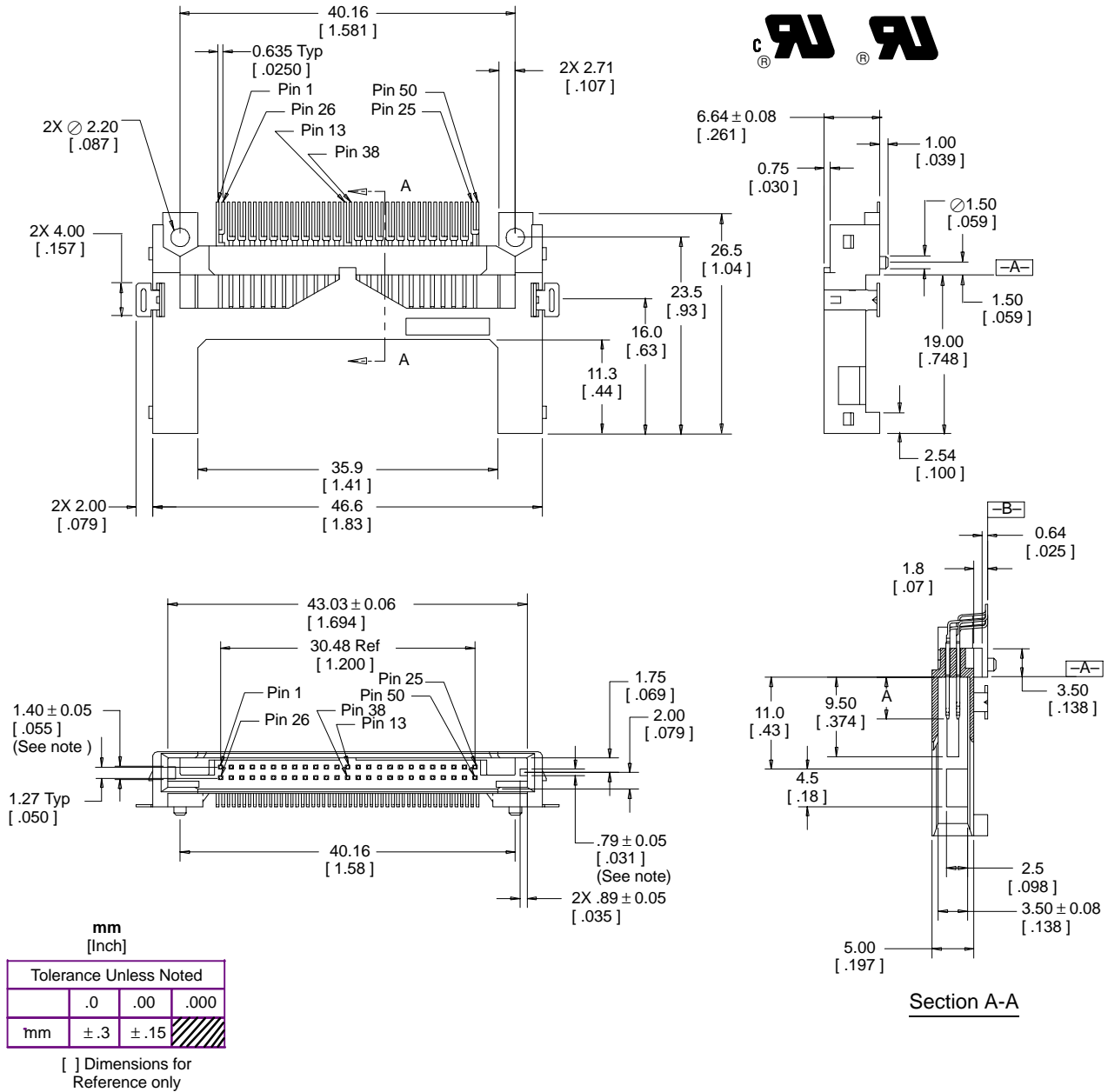

Note: Normal ( Option "7" ) style shown. For Inverse style rotate polarization keys and pin call outs 180°.

## Ordering Information

**N7E50-X516XX-20**

Options: CF Card Polarization  
7 = Normal  
A = Inverse

Plating  
VU = Au Flash over 25μ" [ 0.64μm ] PdNi

TS-0662-17  
Sheet 2 of 4

## 3M Interconnect Solutions Division

6801 River Place Blvd.  
Austin, TX 78726-9000

For technical, sales or ordering information call  
**800-225-5373**

# .050" × .050" CF Card Header Type I, Surface Mount

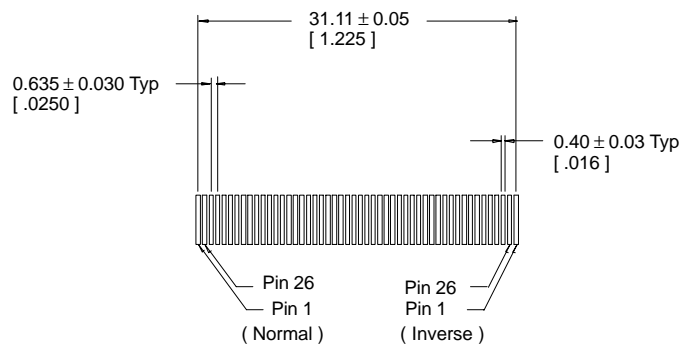
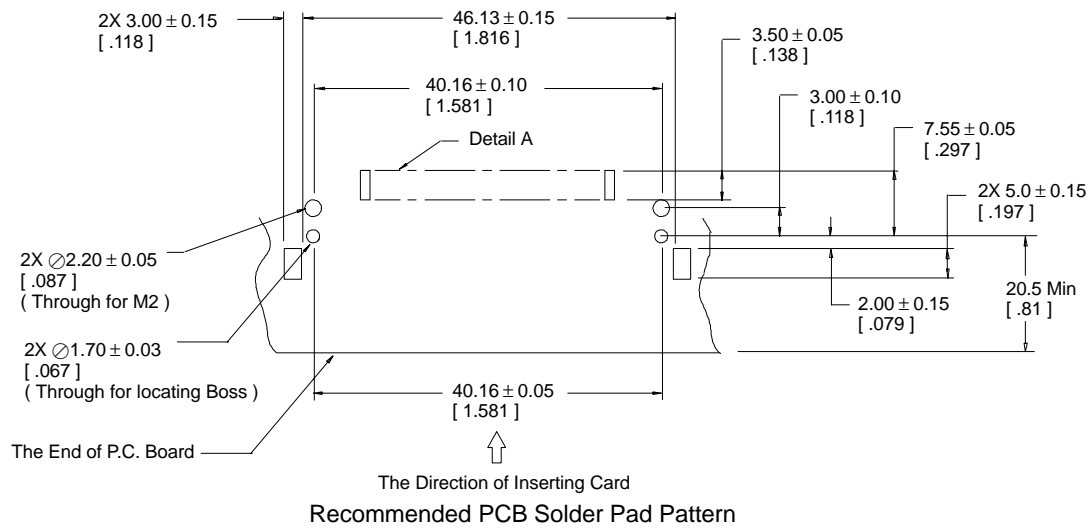

**Detail A**

# .050" × .050" CF Card Header Type I, Surface Mount

## Right Button Ejector 3M Part **D7E50-7316-03**

( Order Separately – See note )

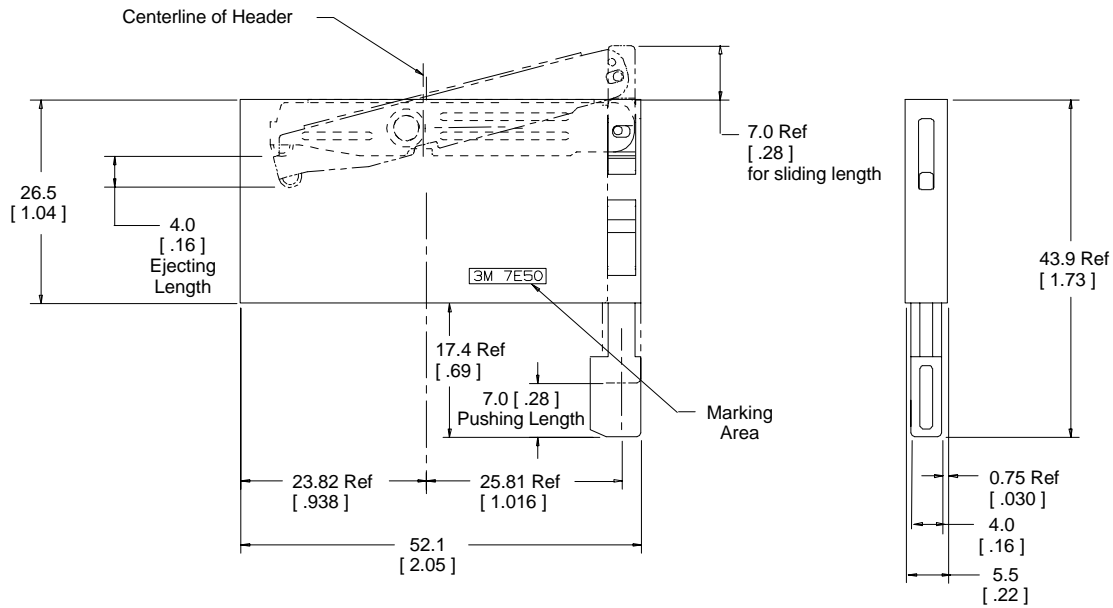

Material  
Holder: Glass Filled LCP  
Button: PBT  
Plate: Stainless Steel

## CF Card Retainer Clip 3M Part **3505-34**

( Order Separately – See note )

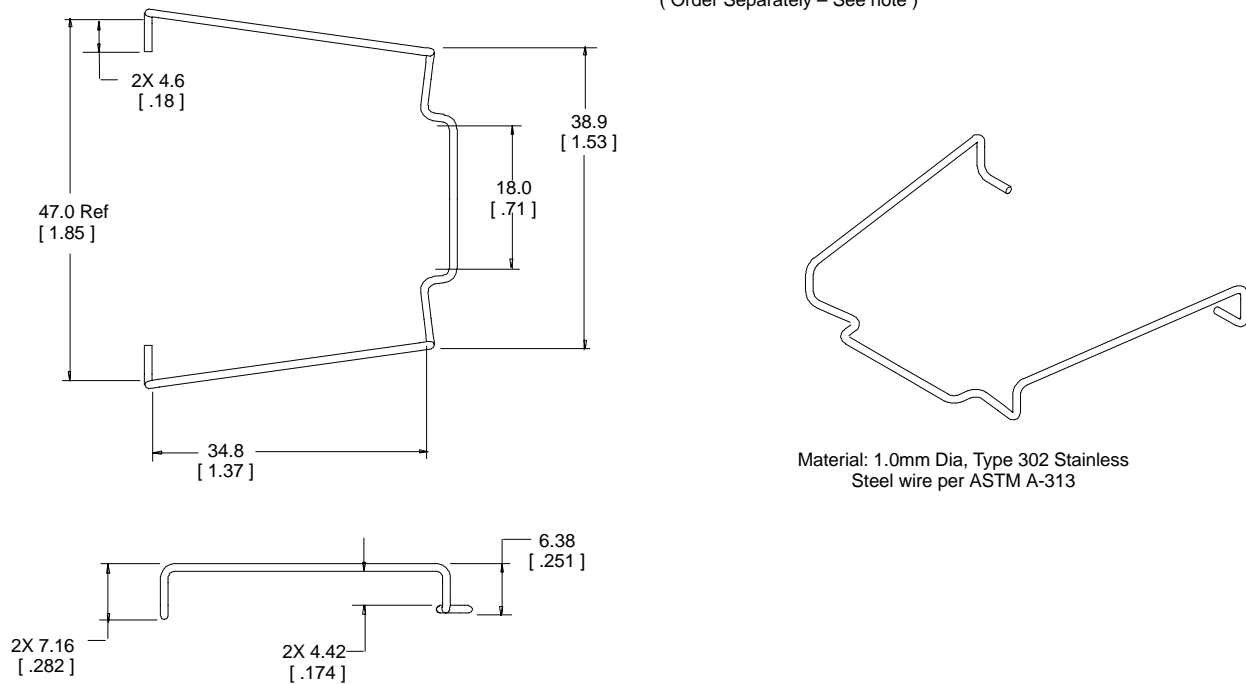

Material: 1.0mm Dia, Type 302 Stainless  
Steel wire per ASTM A-313

Note: Use of either an ejector or a retainer clip excludes the use of the other.

TS-0662-17  
Sheet 4 of 4

### 3M Interconnect Solutions Division

6801 River Place Blvd.  
Austin, TX 78726-9000

For technical, sales or ordering information call  
**800-225-5373**