

DESCRIPTION: VERTICAL MOUNT FEMALE LOW PROFILE/PLASTIC BACK PRESS FIT

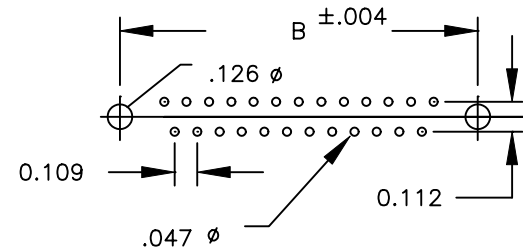
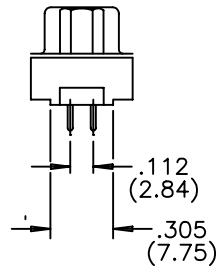
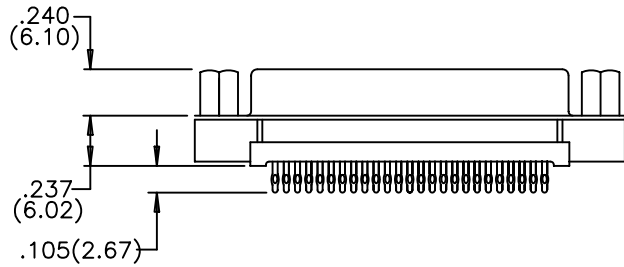
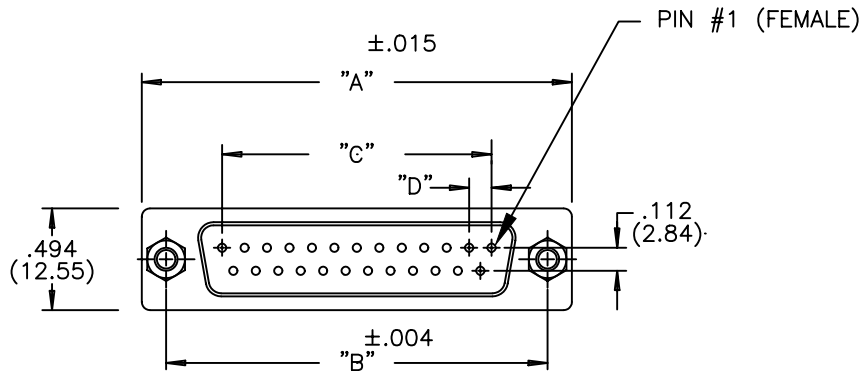

(9, 15, 25, 37 POSITIONS)

MATERIALS:

INSULATOR: THERMOPLASTIC POLYESTER, UL94V-0  
CHEMICAL RESISTANCE, COLOR BLACK

SHELL: STEEL, NICKEL OR TIN PLATED

CONTACT: MALE=BRASS; FEMALE=PHOSPHOR BRONZE  
GOLD FLASH OR 30 MICRO-INCH IN MATING AREA  
TIN-LEAD PLATING ON TAIL ENDS

ELECTRICAL:

CURRENT RATING: 5 AMPERES

DIELECTRIC WITHSTANDING VOLTAGE: 100VAC rms AT SEA LEVEL

INSULATION RESISTANCE: 5000 MEGOHMS MIN.

CONTACT RESISTANCE: 10 MILLIOHMS MAX.

WORKING TEMPERATURE: -55° TO +125° C

191-025-223-XXX

- SERIES \_\_\_\_\_
- NUMBER OF CONTACTS \_\_\_\_\_
- GENDER \_\_\_\_\_
- 1 = MALE  
2 = FEMALE (NO GROUND INDENTS)
- TERMINATION \_\_\_\_\_
- 2 - PRESS FIT
- SHELL \_\_\_\_\_
- 2 = TIN SHELL
- HARDWARE OPTIONS: \_\_\_\_\_
- 00 = .125 HOLE  
55 = 4-40 INSERT  
56 = 4-40 INSERT WITH BOARD LOCKS  
57 = 4-40 STANDOFF WITH BOARD LOCKS  
59 = 4-40 STANDOFF
- PLATING \_\_\_\_\_
- 1 = GOLD FLASH  
2 = 30 MICRO-INCH GOLD

NUMBER OF CONTACTS	"A" Inch (mm)	"B" Inch (mm)	"C" Inch (mm)	"D" Inch (mm)
9	1.214 (30.84)	.984 (24.99)	.432 (10.97)	.109 (2.76)
15	1.545 (39.24)	1.312 (33.32)	.756 (19.20)	.109 (2.76)
25	2.088 (53.04)	1.852 (47.04)	1.304 (33.12)	.109 (2.76)
37	2.730 (69.34)	2.500 (63.50)	1.956 (49.68)	.109 (2.76)



THESE DRAWINGS AND SPECIFICATIONS ARE THE PROPERTY OF NorComp AND SHALL NOT BE REPRODUCED, COPIED OR USED AS THE BASIS FOR THE MANUFACTURE OF SALE OF APPARATUS WITHOUT WRITTEN PERMISSION.

DRAWN: PAM JENKINS		DATE: 8-22-01	
CHECKED:		DATE:	
SCALE:	SHEET 1	OF 1	REV 3
DWG NO. 191-XXX-222-XXX			

NorComp

00 = .125 DIA. HOLE

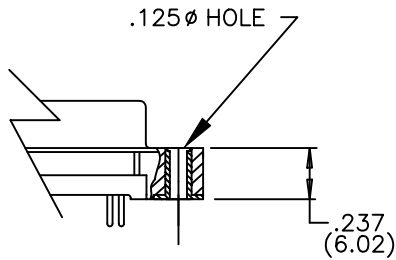

55 = 4-40 INSERT

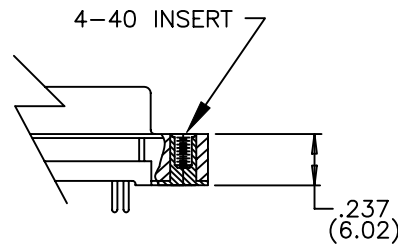

56 = 4-40 INSERT WITH BOARD LOCK

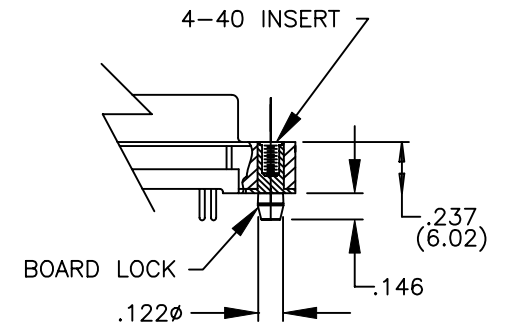

57 = 4-40 STANDOFF WITH BOARD LOCKS

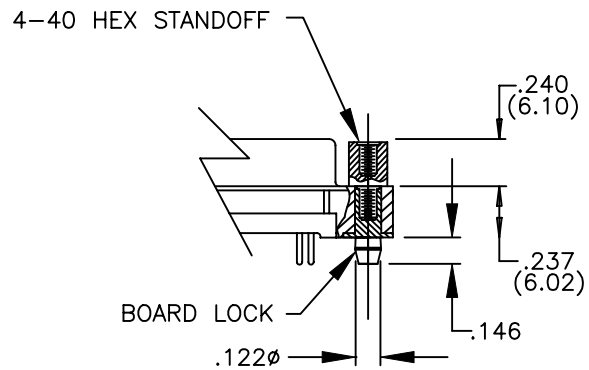

59 = 4-40 STANDOFF

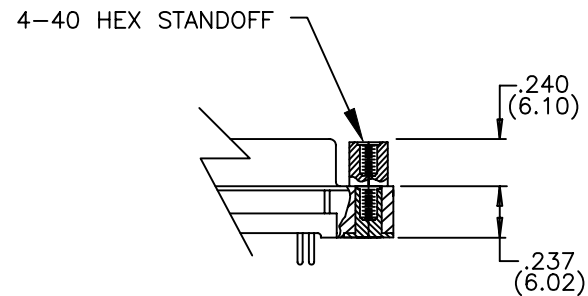

THESE DRAWINGS AND SPECIFICATIONS ARE THE PROPERTY OF NorComp AND SHALL NOT BE REPRODUCED, COPIED OR USED AS THE BASIS FOR THE MANUFACTURE OR SALE OF APPARATUS WITHOUT WRITTEN PERMISSION.

DRAWN:  
PAM JENKINS

DATE:  
1-18-03

CHECKED:

DATE:

**NorComp**

SCALE: SHEET 1 OF 1 REV 1

DWG NO. 191 SERIES HARDWARE OPTIONS