

Units: mm

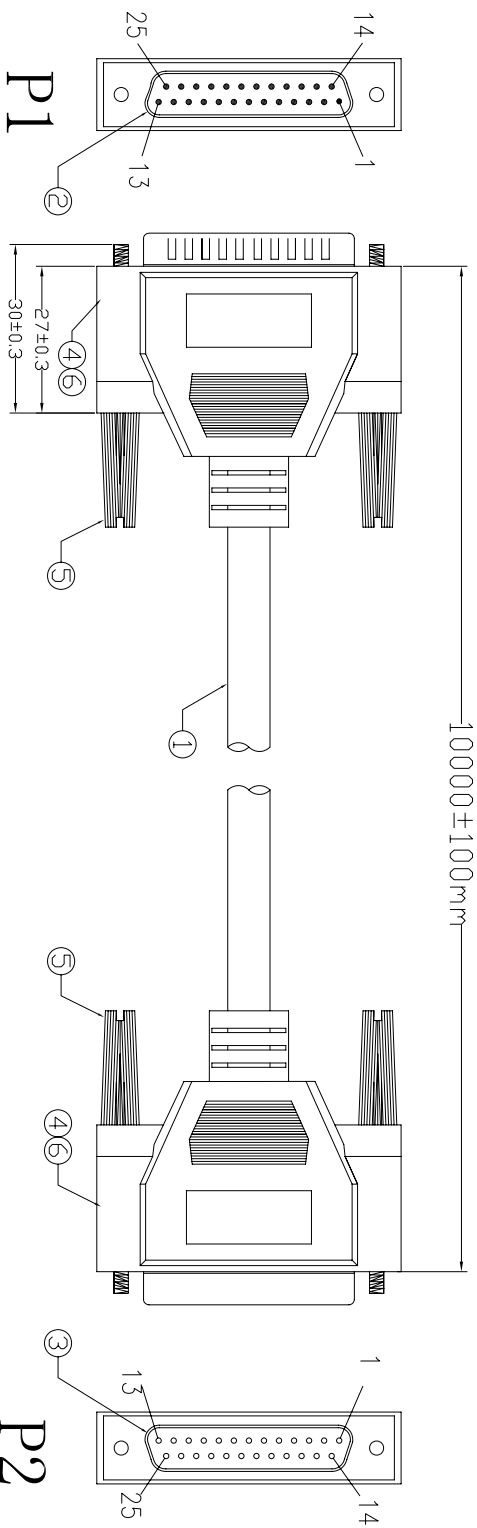

Electrical test:
 1. 100% short, open, miswire test
 2. Conduct resistance: 3 Ohm(max)
 3. Insulation resistance: 20Mohm(min)
 4. dielectric test: DC 300V

PIN ASSIGNMENT	
P1 1	BLACK
P1 2	BROWN
P1 3	RED
P1 4	ORANGE
P1 5	YELLOW
P1 6	GREEN
P1 7	BLUE
P1 8	PURPLE
P1 9	GRAY
P1 10	WHITE
P1 11	PINK
P1 12	LIGHT/GREEN
P1 13	RED/BLACK
P1 14	ORANGE/BLACK
P1 15	YELLOW/BLACK
P1 16	GREEN/BLACK
P1 17	BLUE/BLACK
P1 18	PURPLE/BLACK
P1 19	WHITE/BLACK
P1 20	RED/WHITE
P1 21	ORANGE/WHITE
P1 22	GREEN/WHITE
P1 23	BLUE/WHITE
P1 24	PURPLE/WHITE
P1 25	BROWN/WHITE
P2 1	BLACK
P2 2	BROWN
P2 3	RED
P2 4	ORANGE
P2 5	YELLOW
P2 6	GREEN
P2 7	BLUE
P2 8	PURPLE
P2 9	GRAY
P2 10	WHITE
P2 11	PINK
P2 12	LIGHT/GREEN
P2 13	RED/BLACK
P2 14	ORANGE/BLACK
P2 15	YELLOW/BLACK
P2 16	GREEN/BLACK
P2 17	BLUE/BLACK
P2 18	PURPLE/BLACK
P2 19	WHITE/BLACK
P2 20	RED/WHITE
P2 21	ORANGE/WHITE
P2 22	GREEN/WHITE
P2 23	BLUE/WHITE
P2 24	PURPLE/WHITE
P2 25	BROWN/WHITE
SHELL	SHELL

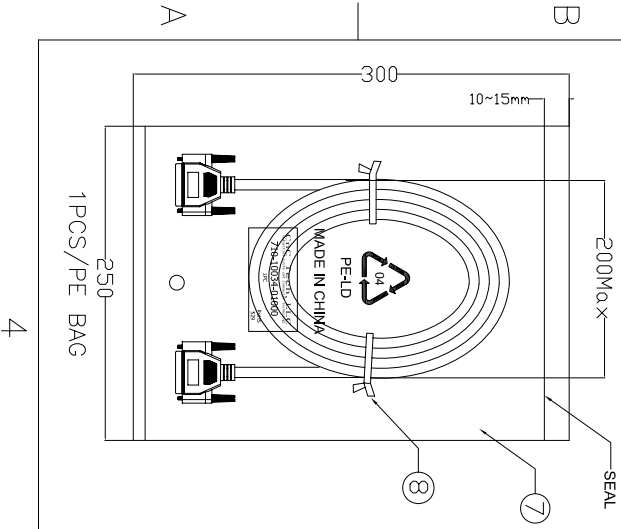

NO.	NAME	Q'TY	SPECIFICATION
①	CABLE	1	NOUL 28#(7/0.12)*25C+D+AL/MY OD6.5mm JACKET BEIGE(IV-29) L=10000±30MM
②	CONN	1	DB 25P MALE SODER TYPE PIN G/F SHELL NI-PLATED INSULATOR COLOR:BLUE
③	CONN	1	DB 25P FEMALE SODER TYPE PIN G/F SHELL NI-PLATED INSULATOR COLOR:BLUE
④	IN JACKET	18g	CLEAR LD-PE (Mould NO:NM-33)
	out JACKET	60g	BEIGE(IV-29) 40P PVC(Mould NO:WM-071)
⑤	SCREW	4	#4-40UNC TYPE L=30mm,NICKEL PLATED,MOLD:BEIGE(IV-29) ABS
⑥	TUBE	2	HEAT SHRINK TUBE BLACK OD1.5*20MM
⑦	PE BAG	1	CLEAR SIZE: 250*300*0.05mm
⑧	TIE	2	WHITE L=200mm

Cnc Tech, LLC
 Industrial Cable and Connector Technology

DRAWN BY	ZHONGHS	DRAWING NO.	
CHECKED BY		CUSTOMER	
APPROVAL BY		ITEM NO.	710-10034-01000
DECIDE BY		DATE	2012-02-06
VERSIONS/EDITION	A/0	PROJECTION	