

THE REVISION STATUS OF ALL SHEETS OF THIS DRAWING IS THE SAME AS SHEET 1

LTR	DESCRIPTION	DATE	BY
-	Released	3/4/96	JCL
A	Redrawn; added interface details	3/30/06	JCL

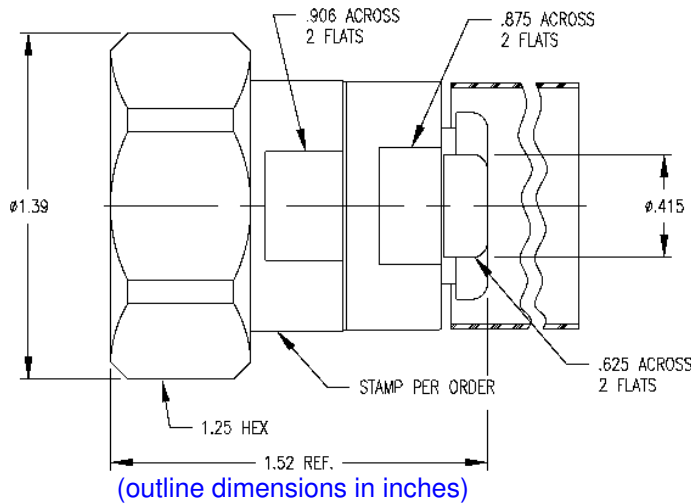

**I. MATERIALS & FINISHES**

- center contact: Silver Plated Brass
- outer contact: Silver Plated Brass
- coupling nut: Silver Plated Brass
- body: Silver Plated Brass
- backnut: Silver Plated Copper
- dielectric: Teflon® PTFE
- gaskets: Silicone Rubber
- attachment: braid clamp

**II. ELECTRICAL PROPERTIES**

- impedance: 50 ohms
- working voltage: 1000 vrms (max)
- vswr: 1.25:1 (max) up to 2 GHz
- insertion loss:  $0.10 \times \sqrt{F}$ ghz
- working voltage: 2700 vrms (sea level)

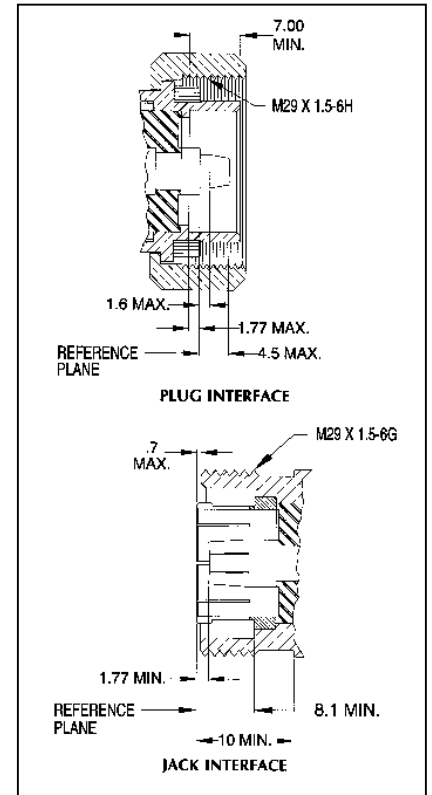

Unless otherwise specified, dimensions are in inches. Tolerances are applicable when specified.

These drawings and specifications contain proprietary information which is the property of Times Microwave Systems.

Approvals		
Drawn	JCL	3/4/96



**TIMES MICROWAVE SYSTEMS**  
 Wallingford, CT 06492  
 (203) 949-8400; (203) 949-8423.Fax  
 www.timesmicrowave.com

<b>TC-400-716MC</b>		
Type-716 DIN male (plug) for LMR-400 Cable		
Size A	CAGE CODE <b>68999</b>	Drawing No.: <b>3190-279</b>
Scale: NA	Rev. (A)	Sheet: 1 of 1