

## Product Features

- Exact footprint substitute for MAR-8SM and MSA-0886<sup>a,b</sup>

Benefits:

- lower device voltage, 3.7 typ.
- lower power dissipation in the MMIC
- may eliminate need for choke (RFC)

- High gain, 31.5 dB at 0.1GHz, reduces component count
- High power output, +12.5 dBm typ.
- Internally Matched to 50 Ohms
- Low noise
- Improved stability
- Protection against power supply transients
- Protected by US Patent, 6,943,629



Generic photo used for illustration purposes only

## MAR-8ASM+

CASE STYLE: WW107

**+RoHS Compliant**

The +Suffix identifies RoHS Compliance. See our web site for RoHS Compliance methodologies and qualifications

## Typical Applications

- Cellular
- PCN instrumentation

## General Description

MAR-8ASM+ (RoHS compliant) is a wideband amplifier offering high dynamic range. It has repeatable performance from lot to lot. It is enclosed in a Micro-X package. MAR-8ASM+ uses Darlington configuration and is fabricated using InGaP HBT technology.

### simplified schematic and pin description

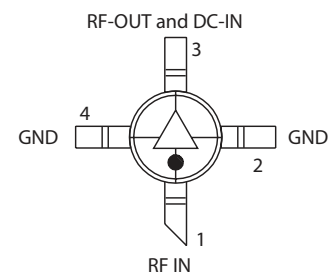
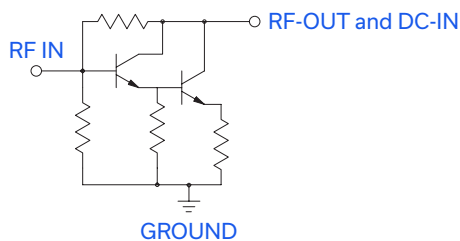

Function	Pin Number	Description
RF IN	1	RF input pin. This pin requires the use of an external DC blocking capacitor chosen for the frequency of operation.
RF-OUT and DC-IN	3	RF output and bias pin. DC voltage is present on this pin; therefore a DC blocking capacitor is necessary for proper operation. An RF choke is needed to feed DC bias without loss of RF signal due to the bias connection, as shown in "Recommended Application Circuit".
GND	2,4	Connections to ground. Use via holes as shown in "Suggested Layout for PCB Design" to reduce ground path inductance for best performance.

#### Notes:

- Suitability for model replacement within a particular system must be determined by and is solely the responsibility of the customer based on, among other things, electrical performance criteria, stimulus conditions, application, compatibility with other components and environmental conditions and stresses.
- The Avago MSA-0885 part number is used for identification and comparison purposes only.

#### Notes

- Performance and quality attributes and conditions not expressly stated in this specification document are intended to be excluded and do not form a part of this specification document.
- Electrical specifications and performance data contained in this specification document are based on Mini-Circuit's applicable established test performance criteria and measurement instructions.
- The parts covered by this specification document are subject to Mini-Circuits standard limited warranty and terms and conditions (collectively, "Standard Terms"); Purchasers of this part are entitled to the rights and benefits contained therein. For a full statement of the Standard Terms and the exclusive rights and remedies thereunder, please visit Mini-Circuits' website at [www.minicircuits.com/MCLStore/terms.jsp](http://www.minicircuits.com/MCLStore/terms.jsp)



**Electrical Specifications at 25°C and 36mA, unless noted**

Parameter	Min.	Typ.	Max.	Units	
Frequency Range*	DC		1	GHz	
Gain	f=0.1 GHz f=1 GHz	— 20 <sup>2</sup>	31.5 25	— —	dB
Input Return Loss	f=DC to 1 GHz		15.5		dB
Output Return Loss	f=DC to 1 GHz		11		dB
Output Power @ 1 dB compression	f=1 GHz		+12.5		dBm
Output IP3	f=1 GHz		+25		dBm
Noise Figure	f=1 GHz		3.1		dB
Recommended Device Operating Current			36		mA
Device Operating Voltage			3.7		V
Device Voltage Variation vs. Temperature at 36 mA			+1.2		mV/°C
Device Voltage Variation vs. Current at 25°C			11.3		mV/mA
Thermal Resistance, junction-to-case <sup>1</sup>			140		°C/W

\*Guaranteed specification DC-1 GHz. Low frequency cut off determined by external coupling capacitors.

**Absolute Maximum Ratings**

Parameter	Ratings
Operating Temperature	-40°C to 85°C
Storage Temperature	-55°C to 100°C
Operating Current	65mA
Power Dissipation	250mW
Input Power	13dBm

Note: Permanent damage may occur if any of these limits are exceeded.

These ratings are not intended for continuous normal operation.

<sup>1</sup>Case is defined as ground leads.

<sup>2</sup>Full temperature range.

**Notes**

- A. Performance and quality attributes and conditions not expressly stated in this specification document are intended to be excluded and do not form a part of this specification document.
- B. Electrical specifications and performance data contained in this specification document are based on Mini-Circuit's applicable established test performance criteria and measurement instructions.
- C. The parts covered by this specification document are subject to Mini-Circuits standard limited warranty and terms and conditions (collectively, "Standard Terms"); Purchasers of this part are entitled to the rights and benefits contained therein. For a full statement of the Standard Terms and the exclusive rights and remedies thereunder, please visit Mini-Circuits' website at [www.minicircuits.com/MCLStore/terms.jsp](http://www.minicircuits.com/MCLStore/terms.jsp)



Product Marking

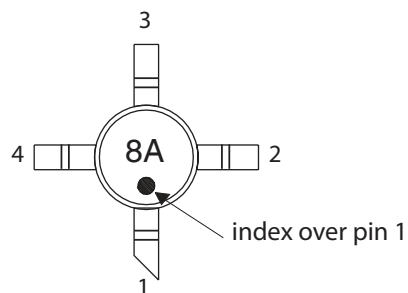

Markings in addition to model number designation may appear for internal quality control purposes.

Additional Detailed Technical Information

Additional information is available on our web site. To access this information enter the model number on our web site home page.

Performance data, graphs, s-parameter data set (.zip file)

Case Style: WW107

Plastic micro-x, .085 body diameter, lead finish: matte-tin

Tape & Reel: F4

7" Reels with 20, 50, 100, 200, 500, 1K devices

13" Reels with 2K, 4K devices

Suggested Layout for PCB Design: PL-253

Evaluation Board: TB-411-8A+

Environmental Ratings: ENV08T3

Recommended Application Circuit

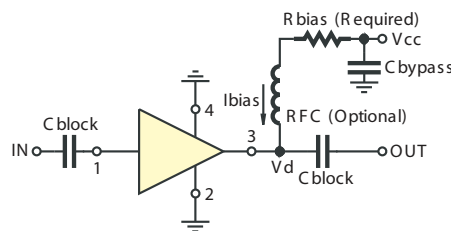

Test Board includes case, connectors, and components (in bold) soldered to PCB

R BIAS <sup>1</sup>	
Vcc	Bias Resistor Value <sup>2</sup>
7	88.7
8	118
9	143
10	174
11	200
12	226
13	255
14	280
15	309

<sup>1</sup> When being used as a substitute for MAR-8SM or MSA-0866, the bias resistor values must be changed to the values in this table.

<sup>2</sup> 1% Resistor values (ohms) for optimum bias.

Notes

- A. Performance and quality attributes and conditions not expressly stated in this specification document are intended to be excluded and do not form a part of this specification document.
- B. Electrical specifications and performance data contained in this specification document are based on Mini-Circuit's applicable established test performance criteria and measurement instructions.
- C. The parts covered by this specification document are subject to Mini-Circuits standard limited warranty and terms and conditions (collectively, "Standard Terms"); Purchasers of this part are entitled to the rights and benefits contained therein. For a full statement of the Standard Terms and the exclusive rights and remedies thereunder, please visit Mini-Circuits' website at [www.minicircuits.com/MCLStore/terms.jsp](http://www.minicircuits.com/MCLStore/terms.jsp)



ESD Rating

Human Body Model (HBM): Class 2 (2000 v to < 4000 v) in accordance with ANSI/ESD STM 5.1 - 2001

MSL Rating

Moisture Sensitivity: MSL1 in accordance with IPC/JEDECJ-STD-020C

MSL Test Flow Chart

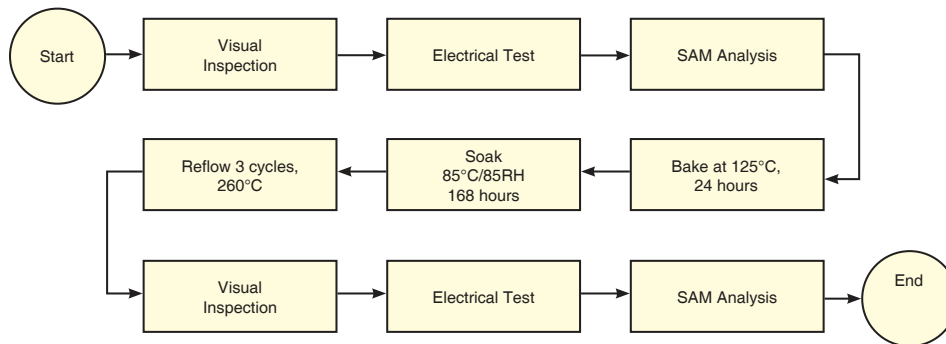

Notes

- A. Performance and quality attributes and conditions not expressly stated in this specification document are intended to be excluded and do not form a part of this specification document.
- B. Electrical specifications and performance data contained in this specification document are based on Mini-Circuit's applicable established test performance criteria and measurement instructions.
- C. The parts covered by this specification document are subject to Mini-Circuits standard limited warranty and terms and conditions (collectively, "Standard Terms"); Purchasers of this part are entitled to the rights and benefits contained therein. For a full statement of the Standard Terms and the exclusive rights and remedies thereunder, please visit Mini-Circuits' website at [www.minicircuits.com/MCLStore/terms.jsp](http://www.minicircuits.com/MCLStore/terms.jsp)

