

- 30 Watt converter in a 1" x 1" metal package
- Cost efficient design
- Wide 4:1 input voltage range: 9-36 and 18-75 VDC
- Operating temperature range -40 to +60 °C without derating
- 1500 VDC I/O-isolation
- Protection against overload, overvoltage and short circuit
- Remote On/Off and Trim function
- Optional heatsink for increased temperature capabilities
- 3-year product warranty

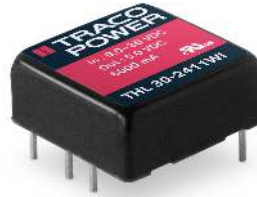

The THL 30WI series extends Traco Power's existing 30 Watt DC/DC converter portfolio with a new generation of 1" x 1" package converters. With the focus on combining cost efficiency and quality this isolated high performance 30 Watt DC/DC converter series is suitable for many different applications. The series comes in an encapsulated, shielded 1" x 1" x 0.4" metal package and offers integrated remote on/off and trim functions. High efficiency up to 88% enables the converter to operate from -40°C to +60°C without derating. All models have a wide 4:1 input voltage range and precisely regulated, isolated outputs. The series meets the latest IT safety certifications (UL 62368-1) and is suitable for uses in mobile equipment, instrumentation, distributed power architectures in communication and industrial electronics and everywhere where cost efficiency and quality are critical factors.

### Models

Order Code	Input Voltage Range	Output 1		Output 2		Efficiency typ.
		Vnom	I <sub>max</sub>	Vnom	I <sub>max</sub>	
THL 30-2410WI	9 - 36 VDC (24 VDC nom.)	3.3 VDC	7'000 mA			87 %
THL 30-2411WI		5 VDC	6'000 mA			88 %
THL 30-2412WI		12 VDC	2'500 mA			88 %
THL 30-2413WI		15 VDC	2'000 mA			88 %
THL 30-2415WI		24 VDC	1'250 mA			88 %
THL 30-2422WI		+12 VDC	1'250 mA	-12 VDC	1'250 mA	88 %
THL 30-2423WI		+15 VDC	1'000 mA	-15 VDC	1'000 mA	88 %
THL 30-4810WI		18 - 75 VDC (48 VDC nom.)	3.3 VDC	7'000 mA		
THL 30-4811WI	5 VDC		6'000 mA			88 %
THL 30-4812WI	12 VDC		2'500 mA			88 %
THL 30-4813WI	15 VDC		2'000 mA			88 %
THL 30-4815WI	24 VDC		1'250 mA			88 %
THL 30-4822WI	+12 VDC		1'250 mA	-12 VDC	1'250 mA	88 %
THL 30-4823WI	+15 VDC		1'000 mA	-15 VDC	1'000 mA	88 %

### Options

THL-HS1	- Optional Heat Sink: <a href="http://www.tracopower.com/products/thl-hs1.pdf">www.tracopower.com/products/thl-hs1.pdf</a>
---------	--

## Input Specifications

Input Current	- At no load	24 Vin models: <b>10 mA typ.</b> 48 Vin models: <b>8 mA typ.</b>
	- At full load	24 Vin models: <b>1'106 mA typ.</b> (3.3 Vout model) <b>1'420 mA typ.</b> (5 Vout model) <b>1'420 mA typ.</b> (12 Vout model) <b>1'420 mA typ.</b> (15 Vout model) <b>1'420 mA typ.</b> (24 Vout model) <b>1'420 mA typ.</b> (12 / -12 Vout model) <b>1'404 mA typ.</b> (15 / -15 Vout model) 48 Vin models: <b>553 mA typ.</b> (3.3 Vout model) <b>702 mA typ.</b> (5 Vout model) <b>702 mA typ.</b> (12 Vout model) <b>702 mA typ.</b> (15 Vout model) <b>694 mA typ.</b> (24 Vout model) <b>694 mA typ.</b> (12 / -12 Vout model) <b>694 mA typ.</b> (15 / -15 Vout model)
Surge Voltage		24 Vin models: <b>50 VDC max.</b> (100 ms max.) 48 Vin models: <b>100 VDC max.</b> (100 ms max.)
Start-up Voltage		24 Vin models: <b>8.4 VDC min. / 8.7 VDC typ. / 9 VDC max.</b> 48 Vin models: <b>16.4 VDC min. / 17.2 VDC typ. / 18 VDC max.</b>
Under Voltage Lockout		24 Vin models: <b>7.8 VDC min. / 8.1 VDC typ. / 8.4 VDC max.</b> 48 Vin models: <b>15.5 VDC min. / 16 VDC typ. / 16.4 VDC max.</b>
Reflected Ripple Current		<b>30 mA<sub>p-p</sub> typ.</b>
Recommended Input Fuse	- 24 Vin input	3.3 Vout models: <b>4'500 mA</b> (slow blow) 5 Vout models: <b>6'500 mA</b> (slow blow) 12 Vout models: <b>6'500 mA</b> (slow blow) 15 Vout models: <b>6'500 mA</b> (slow blow) 24 Vout models: <b>6'500 mA</b> (slow blow) +12 / -12 Vout models: <b>6'500 mA</b> (slow blow) +15 / -15 Vout models: <b>6'500 mA</b> (slow blow)
	- 48 Vin input	3.3 Vout models: <b>2'500 mA</b> (slow blow) 5 Vout models: <b>3'000 mA</b> (slow blow) 12 Vout models: <b>3'000 mA</b> (slow blow) 15 Vout models: <b>3'000 mA</b> (slow blow) 24 Vout models: <b>3'000 mA</b> (slow blow) +12 / -12 Vout models: <b>3'000 mA</b> (slow blow) +15 / -15 Vout models: <b>3'000 mA</b> (slow blow) (The need of an external fuse has to be assessed in the final application.)
Input Filter		<b>Internal Pi-Type</b>

## Output Specifications

Output Voltage Adjustment		<b>±10%</b> (only single output models) (By external trim resistor) See application note: <a href="http://www.tracopower.com/overview/thl30wi">www.tracopower.com/overview/thl30wi</a> Output power must not exceed rated power!
Voltage Set Accuracy		<b>±1% max.</b>
Regulation	- Input Variation (V <sub>min</sub> - V <sub>max</sub> )	single output models: <b>0.2% max.</b> dual output models: <b>0.5% max.</b>
	- Load Variation (0 - 100%)	single output models: <b>0.2% max.</b> dual output models: <b>1% max.</b> (Output 1) <b>1% max.</b> (Output 2)
	- Voltage Balance (symmetrical load)	dual output models: <b>2% max.</b>
	- Cross Regulation (25% / 100% asym. load)	dual output models: <b>5% max.</b>

All specifications valid at nominal voltage, resistive full load and +25°C after warm-up time, unless otherwise stated.

Ripple and Noise	- 20 MHz Bandwidth	75 mVp-p max. (w/ 0.1 $\mu$ F // 47 $\mu$ F)
Capacitive Load	- single output	3.3 Vout models: 10'000 $\mu$ F max.
		5 Vout models: 7'200 $\mu$ F max.
		12 Vout models: 1'250 $\mu$ F max.
		15 Vout models: 800 $\mu$ F max.
		24 Vout models: 330 $\mu$ F max.
- dual output	12 / -12 Vout models: 680 / 680 $\mu$ F max.	
	15 / -15 Vout models: 470 / 470 $\mu$ F max.	
Minimum Load		Not required
Temperature Coefficient		$\pm 0.02$ %/K max.
Start-up Time		30 ms max.
Start-up Overshoot Voltage		5% max.
Short Circuit Protection		Continuous, Automatic recovery
Output Current Limitation		120 - 170% of Iout max.
		150% typ. of Iout max.
Overvoltage Protection		125% typ. of Vout nom.
		(By Zener diode)
Transient Response	- Response Deviation	3% typ. / 5% max. (25% Load Step)
	- Response Time	250 $\mu$ s typ. (25% Load Step)

### Safety Specifications

Safety Standards	- IT / Multimedia Equipment	EN 62368-1 IEC 62368-1 UL 62368-1
	- Certification Documents	<a href="http://www.tracopower.com/overview/thl30wi">www.tracopower.com/overview/thl30wi</a>
Pollution Degree		PD 3

### EMC Specifications

EMI Emissions	- Conducted Emissions	EN 55032 class A (with external filter) EN 55032 class B (with external filter)
	- Radiated Emissions	EN 55032 class A (with external filter) EN 55032 class B (with external filter)
	External filter proposal:	<a href="http://www.tracopower.com/overview/thl30wi">www.tracopower.com/overview/thl30wi</a>
EMS Immunity	- Electrostatic Discharge	EN 55035 (Multimedia) Air: EN 61000-4-2, $\pm 8$ kV, perf. criteria A Contact: EN 61000-4-2, $\pm 6$ kV, perf. criteria A
	- RF Electromagnetic Field	EN 61000-4-3, 10 V/m, perf. criteria A
	- EFT (Burst) / Surge	EN 61000-4-4, $\pm 2$ kV, perf. criteria A EN 61000-4-5, $\pm 2$ kV, perf. criteria A
	- Conducted RF Disturbances	External filter proposal: <a href="http://www.tracopower.com/overview/thl30wi">www.tracopower.com/overview/thl30wi</a> EN 61000-4-6, 10 Vrms, perf. criteria A
	- PF Magnetic Field	Continuous: EN 61000-4-8, 100 A/m, perf. criteria A 1 s: EN 61000-4-8, 1000 A/m, perf. criteria A

### General Specifications

Relative Humidity		95% max. (non condensing)
Temperature Ranges	- Operating Temperature	-40°C to +80°C -40°C to +85°C (with Heat Sink)
	- Case Temperature	+105°C max.
	- Storage Temperature	-55°C to +125°C
Power Derating	- High Temperature	2.6 %/K above 65°C (average) 3 %/K above 70°C (average) (with Heat Sink)
		See application note: <a href="http://www.tracopower.com/overview/thl30wi">www.tracopower.com/overview/thl30wi</a>
Cooling System		Natural convection (20 LFM)

All specifications valid at nominal voltage, resistive full load and +25°C after warm-up time, unless otherwise stated.

Remote Control	- Voltage Controlled Remote  - Off Idle Input Current - Remote Pin Input Current	On: 3.5 to 12 VDC or open circuit Off: 0 to 1.2 VDC or short circuit Refers to 'Remote' and '-Vin' Pin 2 mA typ. -0.5 to 0.5 mA
Altitude During Operation		6'000 m max.
Switching Frequency		158 - 193 kHz (PWM) (3,3 Vout models) 223 - 273 kHz (PWM) (5 Vout models) 257 - 314 kHz (PWM) (other output models)
Insulation System		Functional Insulation
Isolation Test Voltage	- Input to Output, 60 s - Input to Output, 1 s - Input to Case, 60 s - Output to Case, 60 s	1'500 VDC 1'800 VDC 1'000 VDC 1'000 VDC
Isolation Resistance	- Input to Output, 500 VDC	1'000 MΩ min.
Isolation Capacitance	- Input to Output, 100 kHz, 1 V	1'500 pF max.
Reliability	- Calculated MTBF	1'310'710 h (MIL-HDBK-217F, ground benign)
Washing Process		Allowed (hermetical product)
	See Cleaning Guideline:	<a href="http://www.tracopower.com/info/cleaning.pdf">www.tracopower.com/info/cleaning.pdf</a>
Environment	- Vibration  - Mechanical Shock  - Thermal Shock	IEC 60068-2-64 2.4 g, 3 axis, random waveform, 30 min IEC 60068-2-27 30 g, 3 axis, half sine, 11 ms IPC-9592B -40 to +125°C, 100 cycles, 30 min each
Housing Material		Plastic base-plate w. metal case
Base Material		Non-conductive FR4 (UL 94 V-0 rated)
Potting Material		Silicone (UL 94 V-0 rated)
Pin Material		Copper
Pin Foundation Plating		Nickel (2 - 4 μm)
Pin Surface Plating		Tin (3 - 5 μm), matte
Housing Type		Metal Case
Mounting Type		PCB Mount
Connection Type		THD (Through-Hole Device)
Footprint Type		1" x 1"
Soldering Profile		Wave Soldering 260°C / 10 s max.
Weight		25 g
Thermal Impedance	- Case to Ambient	11 K/W typ. 10 K/W typ. (with Heat Sink)
Environmental Compliance	- REACH Declaration  - RoHS Declaration	<a href="http://www.tracopower.com/info/reach-declaration.pdf">www.tracopower.com/info/reach-declaration.pdf</a> REACH SVHC list compliant REACH Annex XVII compliant <a href="http://www.tracopower.com/info/rohs-declaration.pdf">www.tracopower.com/info/rohs-declaration.pdf</a> Exemptions: 7a (RoHS exemptions refer to the component concentration only, not to the overall concentration in the product (O5A rule). The SCIP number is provided on request.)

## Supporting Documents

Overview Link (for additional Documents)

[www.tracopower.com/overview/thl30wi](http://www.tracopower.com/overview/thl30wi)

All specifications valid at nominal voltage, resistive full load and +25°C after warm-up time, unless otherwise stated.

**Outline Dimensions**

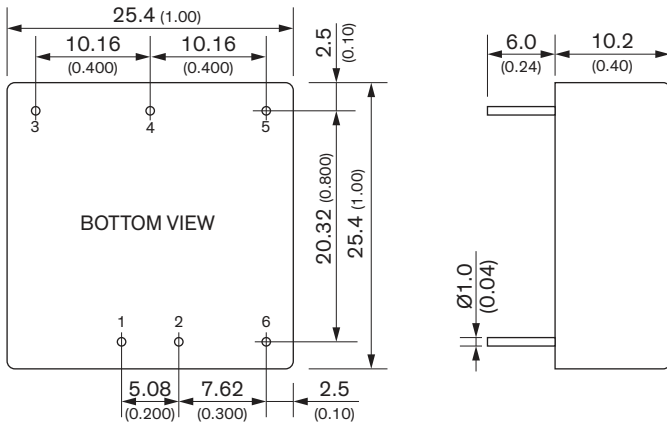

Pinout		
Pin	Single	Dual
1	+Vin	+Vin
2	-Vin	-Vin
3	+Vout	+Vout
4	Trim	Common
5	-Vout	-Vout
6	Remote On/Off	Remot On/Off

Dimensions in mm (inch)  
 Tolerance: X.X ±0.5 (X.XX ±0.02)  
 X.XX ±0.25 (X.XXX ±0.01)  
 Pin Diameter: ±0.05 (±0.002)