



Low-Voltage, Combination Single-Ended 8-to-1/Differential 4-to-1 Multiplexer

MAX4598

General Description

The MAX4598 low-voltage, CMOS analog IC is a configurable single-ended 8-to-1/differential 4-to-1 multiplexer. In addition to the input channels, both V+ and GND can be switched to the output channels, enabling the supply voltages to be monitored. The MAX4598 operates from a single +2.7V to +12V supply or from dual $\pm 6V$ supplies. The device has low on-resistance (75 Ω max) and TTL-compatible logic inputs from either $\pm 5V$ or a single +5V supply. Each switch can handle Rail-to-Rail[®] analog signals. The MAX4598 has two modes of operation: as a standard multiplexer and as a "latchable" multiplexer where the address lines are strobed. The off-leakage current is only 0.1nA at $T_A = +25^\circ\text{C}$ and 2nA at $T_A = +85^\circ\text{C}$. ESD protection is $> 2\text{kV}$ per Method 3015.7.

The MAX4598 is available in small 20-pin SSOP, SO, and DIP packages.

Applications

ADC Systems
 Battery-Operated Equipment
 Test Equipment
 Avionics
 Audio-Signal Routing
 Networking

Features

- ◆ V+ and GND Can Be Switched to the Output Channels
- ◆ 75 Ω (max) On-Resistance
- ◆ Single-Ended or Differential Operation
- ◆ 2pC (typ) Charge Injection
- ◆ Latched or Unlatched Operation
- ◆ TTL-Compatible Logic Inputs at $\pm 5V$ Supply
- ◆ Handles Rail-to-Rail Analog Signals

Ordering Information

PART	TEMP. RANGE	PIN-PACKAGE
MAX4598CAP	0°C to +70°C	20 SSOP
MAX4598CWP	0°C to +70°C	20 Wide SO
MAX4598CCP	0°C to +70°C	20 Plastic DIP
MAX4598C/D	0°C to +70°C	Dice*
MAX4598EAP	-40°C to +85°C	20 SSOP
MAX4598EWP	-40°C to +85°C	20 Wide SO
MAX4598EPP	-40°C to +85°C	20 Plastic DIP

*Contact factory for dice specifications.

Pin Configuration/Functional Diagram

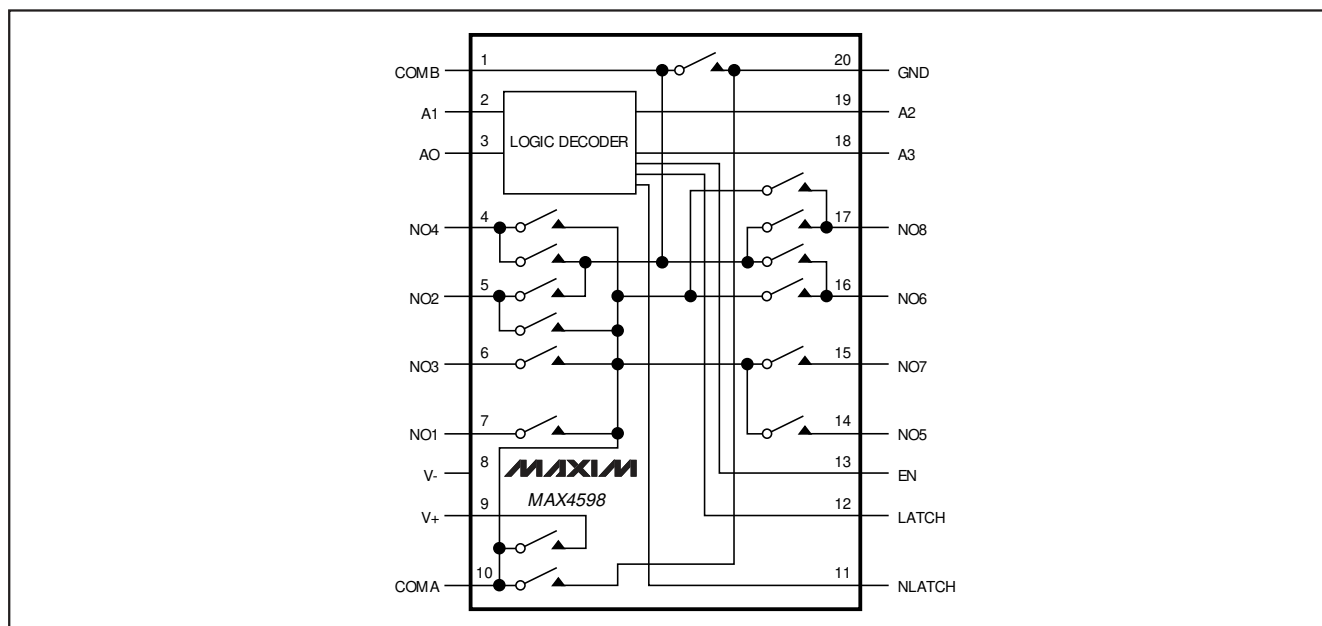

Rail-to-Rail is a registered trademark of Nippon Motorola, Ltd.



Maxim Integrated Products 1

For free samples & the latest literature: <http://www.maxim-ic.com>, or phone 1-800-998-8800.
 For small orders, phone 1-800-835-8769.

Low-Voltage, Combination Single-Ended 8-to-1/Differential 4-to-1 Multiplexer

ABSOLUTE MAXIMUM RATINGS

V+ to GND	-0.3V to +13V	Continuous Power Dissipation (TA = +70°C)	
V- to GND	-13V to +0.3V	SSOP (derate 8mW/°C above +70°C)	640mW
V+ to V-	-0.3V to +13V	Wide SO (derate 10mW/°C above +70°C)	800mW
A_, EN, LATCH, NLATCH, NO_, COM_ (Note 1)	(V- - 0.3V) to (V+ + 0.3V)	Plastic DIP (derate 10.53mW/°C above +70°C)	889mW
Continuous Current (any terminal)	±20mA	Operating Temperature Ranges	
Peak Current, NO_ or COM_ (pulsed at 1ms, 10% duty cycle max)	±40mA	MAX4598C_P	0°C to +70°C
		MAX4598E_P	-40°C to +85°C
		Storage Temperature Range	-65°C to +160°C
		Lead Temperature (soldering, 10sec)	+300°C

Note 1: Signals on NO_, COM_, EN, LATCH, NLATCH, or A_ exceeding V+ or V- are clamped by internal diodes. Limit forward current to maximum current ratings

Stresses beyond those listed under "Absolute Maximum Ratings" may cause permanent damage to the device. These are stress ratings only, and functional operation of the device at these or any other conditions beyond those indicated in the operational sections of the specifications is not implied. Exposure to absolute maximum rating conditions for extended periods may affect device reliability.

ELECTRICAL CHARACTERISTICS—Dual Supplies

(V+ = +5V ±10%, V- = -5V ±10%, VIH = 2.4V, VIL = 0.8V, TA = TMIN to TMAX, unless otherwise noted. Typical values are at TA = +25°C.) (Note 2)

PARAMETER	SYMBOL	CONDITIONS	MIN	TYP	MAX	UNIT	
SWITCH							
Analog Signal Range	VCOM_, VNO_	(Note 3)	V-		V+	V	
On-Resistance	RON	ICOM_ = 1mA, VNO_ = ±3.0V, V+ = 4.5V, V- = -4.5V	TA = +25°C	45	75	Ω	
			TA = TMIN to TMAX		100		
On-Resistance Matching Between Channels (Note 4)	ΔRON	ICOM_ = 1mA, VNO_ = ±3.0V, V+ = 4.5V, V- = -4.5V	TA = +25°C	1	4	Ω	
			TA = TMIN to TMAX		6		
On-Resistance Flatness (Note 5)	RFLAT	ICOM_ = 1mA; VNO_ = -3V, 0, 3V; V+ = 4.5V, V- = -4.5V	TA = +25°C	7	10	Ω	
			TA = TMIN to TMAX		13		
NO Off-Leakage Current (Note 6)	INO(OFF)	VNO_ = ±4.5V, VCOM_ = ±4.5V, V+ = 5.5V, V- = -5.5V	TA = +25°C	-0.1	0.01	0.1	nA
			TA = TMIN to TMAX	-2		2	
COM Off-Leakage Current (Note 6)	ICOM(OFF)	VCOM_ = ±4.5V, VNO_ = ±4.5V, V+ = 5.5V, V- = -5.5V	TA = +25°C	-0.2	0.01	0.2	nA
			TA = TMIN to TMAX	-10		10	
COM On-Leakage Current (Note 6)	ICOM(ON)	VCOM_ = ±4.5V, VNO_ = ±4.5V, V+ = 5.5V, V- = -5.5V	TA = +25°C	-0.2	0.01	0.2	nA
			TA = TMIN to TMAX	-10		10	
LOGIC INPUTS							
Input High Voltage	VIH		2.4	1.7		V	
Input Low Voltage	VIL			1.4	0.8	V	
Input Current with Input Voltage High	IIH	VEN = VA_ = VLATCH = VNLATCH = VCAL = V+	-0.1	0.01	0.1	μA	
Input Current with Input Voltage Low	IIL	VEN = VA_ = VLATCH = VNLATCH = VCAL = 0	-0.1	0.01	0.1	μA	

Low-Voltage, Combination Single-Ended 8-to-1/Differential 4-to-1 Multiplexer

MAX4598

ELECTRICAL CHARACTERISTICS—Dual Supplies (continued)

(V₊ = +5V ±10%, V₋ = -5V ±10%, V_{IH} = 2.4V, V_{IL} = 0.8V, T_A = T_{MIN} to T_{MAX}, unless otherwise noted. Typical values are at T_A = +25°C.) (Note 2)

PARAMETER	SYMBOL	CONDITIONS	MIN	TYP	MAX	UNIT	
SUPPLY							
Power-Supply Range			±2.7		±6	V	
Positive Supply Current	I ₊	V _{EN} = V _{A_} = V _{LATCH} = V _{NLATCH} = 0 or V ₊ , V ₊ = 5.5V, V ₋ = -5.5V	T _A = +25°C	-1	0.001	1	μA
			T _A = T _{MIN} to T _{MAX}	-5		5	
Negative Supply Current	I ₋	V _{EN} = V _{A_} = V _{LATCH} = V _{NLATCH} = 0 or V ₊ , V ₊ = 5.5V, V ₋ = -5.5V	T _A = +25°C	-1	0.001	1	μA
			T _A = T _{MIN} to T _{MAX}	-5		5	
GND Supply Current	I _{GND}	V _{EN} = V _{A_} = V _{LATCH} = V _{NLATCH} = 0 or V ₊ , V ₊ = 5.5V, V ₋ = -5.5V	T _A = +25°C	-1	0.001	1	μA
			T _A = T _{MIN} to T _{MAX}	-5		5	
DYNAMIC							
Transition Time	t _{TRANS}	Figure 1	T _A = +25°C	65	100	ns	
			T _A = T _{MIN} to T _{MAX}		150		
Break-Before-Make Interval (Note 3)	t _{OPEN}	Figure 2	T _A = +25°C	4	10	ns	
Enable Turn-On Time	t _{ON}	Figure 3	T _A = +25°C	55	90	ns	
			T _A = T _{MIN} to T _{MAX}		120		
Enable Turn-Off Time	t _{OFF}	Figure 3	T _A = +25°C	40	70	ns	
			T _A = T _{MIN} to T _{MAX}		100		
Charge Injection (Note 3)	V _{CTE}	C _L = 1nF, V _{NO_} = 0, Figure 4	T _A = +25°C	2	5	pC	
Off-Isolation (Note 7)	V _{ISO}	V _{EN} = 0, f = 1MHz, Figure 5	T _A = +25°C	-90		dB	
Crosstalk Between Channels (Note 8)	V _{CT}	V _{EN} = 2.4V, f = 1MHz, V _{GEN} = 1Vp-p, Figure 5	T _A = +25°C	-80		dB	
Logic Input Capacitance	C _{IN}	f = 1MHz	T _A = +25°C	3		pF	
NO Off-Capacitance	C _{OFF}	f = 1MHz, V _{EN} = V _{COM_} = 0, Figure 6	T _A = +25°C	3		pF	
COM Off-Capacitance	C _{COM(OFF)}	f = 1MHz, V _{EN} = V _{COM_} = 0, Figure 6	T _A = +25°C	15		pF	
COM On-Capacitance	C _{COM(ON)}	f = 1MHz, V _{EN} = 2.4V, V _{COM_} = 0	T _A = +25°C	26		pF	
LATCH TIMING (Note 3)							
Setup Time	t _S	Figure 7	T _A = +25°C	30	70	ns	
			T _A = T _{MIN} to T _{MAX}		80		
Hold Time	t _H	Figure 7	T _A = +25°C	-10	0	ns	
			T _A = T _{MIN} to T _{MAX}	-10			

Low-Voltage, Combination Single-Ended 8-to-1/Differential 4-to-1 Multiplexer

ELECTRICAL CHARACTERISTICS—Single +5V Supply

($V_+ = +5V \pm 10\%$, $V_- = 0$, $V_{IH} = 2.4V$, $V_{IL} = 0.8V$, $T_A = T_{MIN}$ to T_{MAX} , unless otherwise noted. Typical values are at $T_A = +25^\circ C$.) (Note 2)

PARAMETER	SYMBOL	CONDITIONS	MIN	TYP	MAX	UNIT
SWITCH						
Analog Signal Range	$V_{NO_}$, $V_{COM_}$	(Note 3)	0		V_+	V
On-Resistance	R_{ON}	$I_{COM_} = 1mA$, $V_{NO_} = 3.0V$, $V_+ = 4.5V$	$T_A = +25^\circ C$	80	150	Ω
			$T_A = T_{MIN}$ to T_{MAX}		200	
On-Resistance Matching Between Channels (Notes 3, 4)	ΔR_{ON}	$I_{COM_} = 1mA$, $V_{NO_} = 3.0V$, $V_+ = 4.5V$	$T_A = +25^\circ C$	2	8	Ω
			$T_A = T_{MIN}$ to T_{MAX}		12	
On-Resistance Flatness	R_{FLAT}	$I_{COM_} = 1mA$; $V_{NO_} = 3V, 2V, 1V$; $V_+ = 4.5V$	$T_A = +25^\circ C$	8		Ω
NO Off-Leakage Current (Notes 6, 9)	$I_{NO(OFF)}$	$V_{NO_} = 4.5V, 1V$; $V_{COM_} = 1V, 4.5V$; $V_+ = 5.5V$	$T_A = +25^\circ C$	-0.1	0.1	nA
			$T_A = T_{MIN}$ to T_{MAX}	-2	2	
COM Off-Leakage Current (Notes 6, 9)	$I_{COM(OFF)}$	$V_{COM_} = 4.5V, 1V$; $V_{NO_} = 1V, 4.5V$; $V_+ = 5.5V$	$T_A = +25^\circ C$	-0.2	0.2	nA
			$T_A = T_{MIN}$ to T_{MAX}	-10	10	
COM On-Leakage Current (Notes 6, 9)	$I_{COM(ON)}$	$V_{COM_} = 4.5V$, $V_{NO_} = 4.5V$, $V_+ = 5.5V$	$T_A = +25^\circ C$	-0.2	0.2	nA
			$T_A = T_{MIN}$ to T_{MAX}	-10	10	
LOGIC INPUTS (Note 3)						
Input High Voltage	V_{IH}		2.4	1.6		V
Input Low Voltage	V_{IL}			1.3	0.8	V
Input Current with Input Voltage High		$V_{EN} = V_{LATCH} = V_{A_} = V_{NLATCH} = V_+$	-0.1	0.01	0.1	μA
Input Current with Input Voltage Low		$V_{EN} = V_{LATCH} = V_{A_} = V_{NLATCH} = 0$	-0.1	0.01	0.1	μA
SUPPLY						
Power-Supply Range			2.7		12.0	V
Positive Supply Current (Note 3)	I_+	$V_{EN} = V_{A_} = V_{LATCH} = V_{NLATCH} = 0$ or V_+ , $V_+ = 5.5V$	$T_A = +25^\circ C$	-1	1	μA
			$T_A = T_{MIN}$ to T_{MAX}	-5	5	
DYNAMIC (Note 3)						
Transition Time	t_{TRANS}	$V_{NO_} = 3V$, Figure 1	$T_A = +25^\circ C$	115	160	ns
			$T_A = T_{MIN}$ to T_{MAX}		210	
Break-Before-Make Interval	t_{OPEN}	Figure 2	$T_A = +25^\circ C$	4	10	ns
Enable Turn-On Time	t_{ON}	Figure 3	$T_A = +25^\circ C$	85	140	ns
			$T_A = T_{MIN}$ to T_{MAX}		170	
Enable Turn-Off Time	t_{OFF}	Figure 3	$T_A = +25^\circ C$	60	100	ns
			$T_A = T_{MIN}$ to T_{MAX}		120	

Low-Voltage, Combination Single-Ended 8-to-1/Differential 4-to-1 Multiplexer

MAX4598

ELECTRICAL CHARACTERISTICS—Single +5V Supply (continued)

(V₊ = +5V ±10%, V₋ = 0, V_{IH} = 2.4V, V_{IL} = 0.8V, T_A = T_{MIN} to T_{MAX}, unless otherwise noted. Typical values are at T_A = +25°C.) (Note 2)

PARAMETER	SYMBOL	CONDITIONS		MIN	TYP	MAX	UNIT
Charge Injection	V _{CTE}	C _L = 1nF, V _{NO-} = 0, Figure 4	T _A = +25°C		1	5	pC
LATCH TIMING (Note 3)							
Setup Time	t _S	Figure 7	T _A = +25°C		30	70	ns
			T _A = T _{MIN} to T _{MAX}			80	
Hold Time	t _H	Figure 7	T _A = +25°C	-10	0		ns
			T _A = T _{MIN} to T _{MAX}	-10			

ELECTRICAL CHARACTERISTICS—Single +3V Supply

(V₊ = +2.7V to +3.6V, V₋ = 0, V_{IH} = 2.4V, V_{IL} = 0.6V, T_A = T_{MIN} to T_{MAX}, unless otherwise noted. Typical values are at T_A = +25°C.)

PARAMETER	SYMBOL	CONDITIONS		MIN	TYP	MAX	UNIT
SWITCH							
Analog Signal Range		(Note 3)		0		V ₊	V
On-Resistance	R _{ON}	I _{COM-} = 0.2mA, V _{NO-} = 1.5V, V ₊ = 2.7V	T _A = +25°C		220	500	Ω
			T _A = T _{MIN} to T _{MAX}			600	
LOGIC INPUTS (Note 3)							
Input High Voltage	I _{IH}			2.4	1.1		V
Input Low Voltage	I _{IL}				1.0	0.6	V
DYNAMIC (Note 3)							
Transition Time	t _{TRANS}	V _{NO1} = 1.5V, V _{NO8} = 0, Figure 1	T _A = +25°C		200	310	ns
Enable Turn-On Time	t _{ON}	V _{NO1} = 1.5V, Figure 3	T _A = +25°C		160	250	ns
Enable Turn-Off Time	t _{OFF}	V _{NO1} = 1.5V, Figure 3	T _A = +25°C		120	180	ns
LATCH TIMING (Note 3)							
Setup Time	t _S	Figure 7	T _A = +25°C		45	80	ns
Hold Time	t _H	Figure 7	T _A = +25°C	-10	0		ns

Note 2: The algebraic convention, where the most negative value is a minimum and the most positive value a maximum, is used in this data sheet.

Note 3: Guaranteed by design.

Note 4: ΔR_{ON} = R_{ON(MAX)} - R_{ON(MIN)}.

Note 5: Flatness is defined as the difference between the maximum and minimum value of on-resistance as measured over the specified analog signal range.

Note 6: Leakage parameters are 100% tested at maximum-rated hot temperature and guaranteed by correlation at +25°C.

Note 7: Off-Isolation = 20log₁₀(V_{COM} / V_{NO}), V_{COM} = output, V_{NO} = input to off switch.

Note 8: Between any two switches.

Note 9: Leakage testing at single supply is guaranteed by testing with dual supplies.

Low-Voltage, Combination Single-Ended 8-to-1/Differential 4-to-1 Multiplexer

Typical Operating Characteristics

($T_A = +25^\circ\text{C}$, unless otherwise noted.)

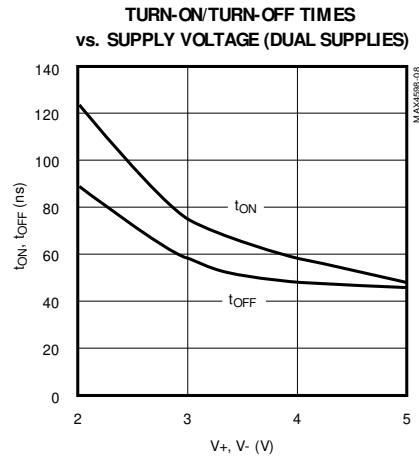
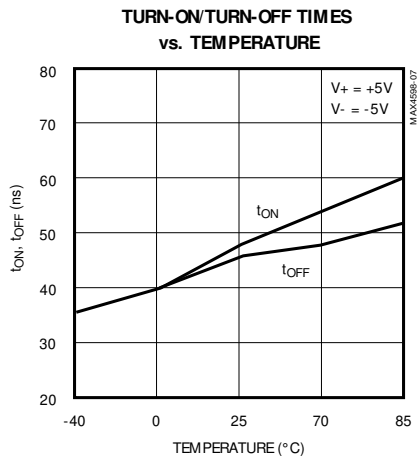
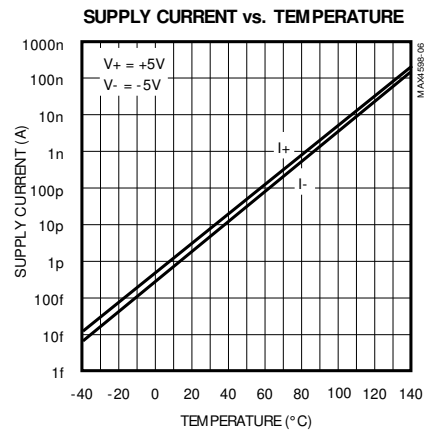
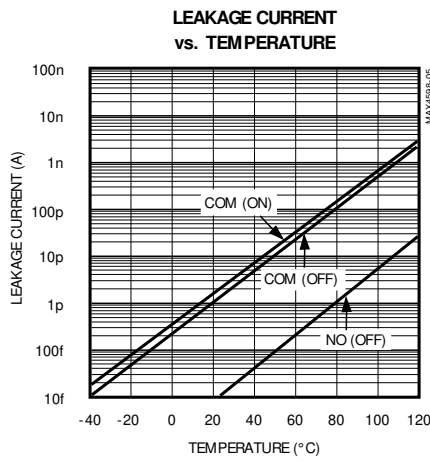
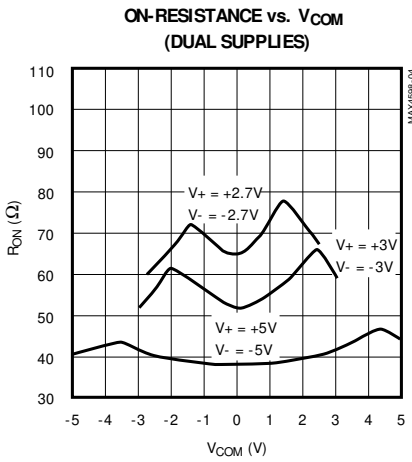
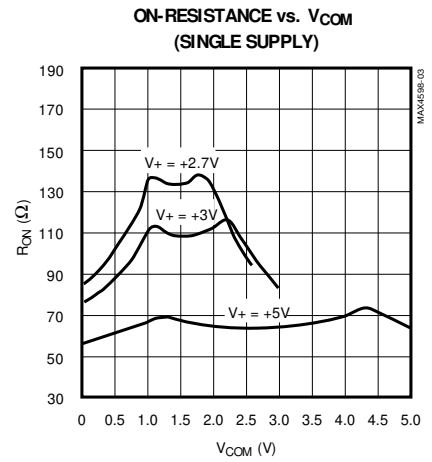
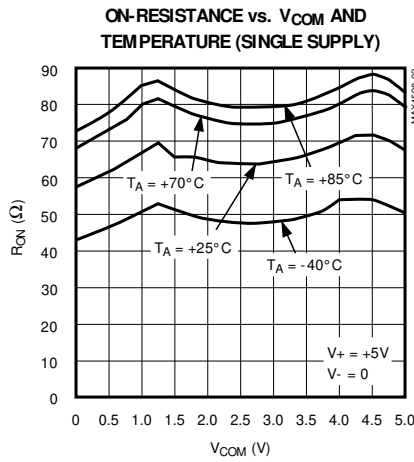
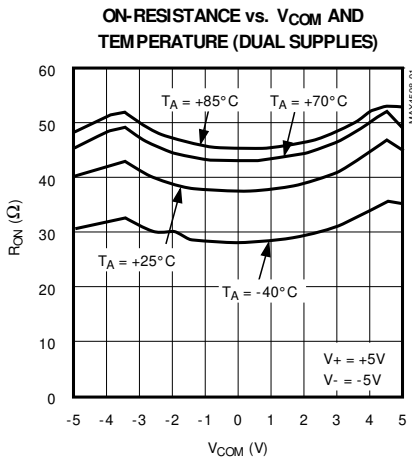

Low-Voltage, Combination Single-Ended 8-to-1/Differential 4-to-1 Multiplexer

MAX4598

Typical Operating Characteristics (continued)

($T_A = +25^\circ\text{C}$, unless otherwise noted.)

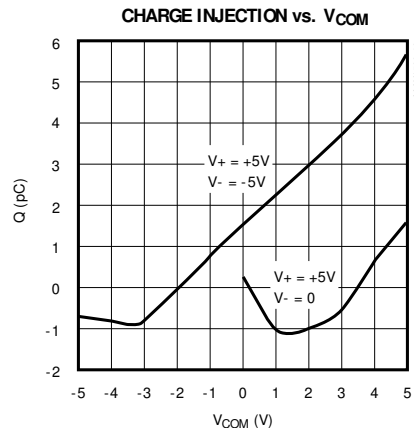
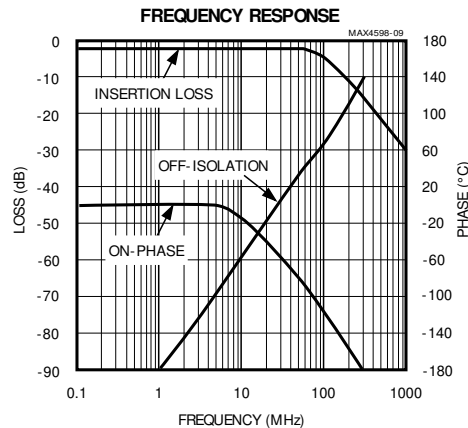

Pin Description

PIN	NAME	FUNCTION
1	COMB	Multiplexer Output B
2	A1	Address Bit 1
3	A0	Address Bit 0
4	NO4	Channel Input 4
5	NO2	Channel Input 2
6	NO3	Channel Input 3
7	NO1	Channel Input 1
8	V-	Negative Supply Voltage
9	V+	Positive Supply Voltage
10	COMA	Multiplexer Output A
11	NLATCH	Data-Strobe Mode Select
12	LATCH	Latch Input
13	EN	Multiplexer Enable
14	NO5	Channel Input 5
15	NO7	Channel Input 7
16	NO6	Channel Input 6
17	NO8	Channel Input 8
18	A3	Address Bit 3
19	A2	Address Bit 2
20	GND	Ground

Detailed Description

The MAX4598 can be configured as a single 8-channel or dual 4-channel multiplexer. In the single 8-to-1 multiplexer configuration, COMA connects to one of the eight inputs (NO1 to NO8), GND, or V_+ by the address inputs A0 to A2 (see *Truth Table*). In the dual 4-to-1 multiplexer configuration, COMA connects to one of the four inputs (NO1, NO3, NO5, NO7), GND, or V_+ , and COMB connects to one of the four inputs (NO2, NO4, NO6, NO8) or GND by the address inputs A0 to A2 (see *Truth Table*).

The MAX4598 functions as a standard multiplexer when NLATCH is high. When NLATCH is low, the condition set by A0 to A3 is activated at the rising edge of LATCH. Otherwise, the outputs remain at the previously set condition.

Applications Information

The MAX4598 construction is typical of most CMOS analog switches. It has three supply pins: V_+ , V_- , and GND. The positive and negative power supplies are used to drive the internal CMOS switches and set the limits of the analog voltage on any switch. Reverse ESD-protection diodes are internally connected between each analog signal pin and V_+ and V_- . If the voltage on any pin exceeds V_+ or V_- by 0.3V, one of the ESD diodes starts to conduct. During normal operation these reverse-biased ESD diodes leak, forming the only current drawn from V_- .

Low-Voltage, Combination Single-Ended 8-to-1/Differential 4-to-1 Multiplexer

Truth Table

A3	A2	A1	A0	EN	LATCH	NLATCH	COMA	COMB
x	x	x	x	0	x	x	High-Z	High-Z
x	x	x	x	1		0	State is latched on the rising edge of LATCH	State is latched on the rising edge of LATCH
0	0	0	0	1	x	1	NO1	GND
0	0	0	1	1	x	1	NO2	GND
0	0	1	0	1	x	1	NO3	GND
0	0	1	1	1	x	1	NO4	GND
0	1	0	0	1	x	1	NO5	GND
0	1	0	1	1	x	1	NO6	GND
0	1	1	0	1	x	1	NO7	GND
0	1	1	1	1	x	1	NO8	GND
1	0	0	0	1	x	1	NO1	NO2
1	0	0	1	1	x	1	NO3	NO4
1	0	1	0	1	x	1	NO5	NO6
1	0	1	1	1	x	1	NO7	NO8
1	1	0	0	1	x	1	GND	GND
1	1	0	1	1	x	1	V+	GND
1	1	1	0	1	x	1	NO8	NO8
1	1	1	1	1	x	1	High-Z	High-Z

x = Don't care

Virtually all the analog leakage current is through the ESD diodes. Although the ESD diodes on a given signal pin are identical, and therefore fairly well balanced, they are reverse-biased differently. Each is biased by either V+ or V- and the analog signal. This means their leakage varies as the signal varies. The difference in the two diodes' leakage from the signal path to the V+ and V- pins constitutes the analog signal-path leakage current. All analog leakage current flows to the supply terminals, not to the other switch terminal. This explains how both sides of a given switch can show leakage currents of either the same or opposite polarity.

There is no connection between the analog signal paths and GND. The analog signal paths consist of an N-channel and a P-channel MOSFET, with their sources and drains paralleled and their gates driven out of phase with V+ and V- by the logic-level translators.

V+ and GND power the internal logic and logic-level translators, and set the input logic thresholds. The logic-level translators convert the logic levels to switched V+ and V- signals to drive the analog switch gates. This drive signal is the only connection between

the logic supplies and the analog supplies. All pins have ESD protection to V+ and to V-.

Increasing V- has no effect on the logic-level thresholds, but it does increase the drive to the P-channel switches, reducing their on-resistance. V- also sets the negative limit of the analog signal voltage.

The logic-level thresholds are CMOS- and TTL-compatible when V+ is +5V. As V+ is raised, the threshold increases slightly; when V+ reaches +12V, the level threshold is about 3.2V, which is above the TTL output high-level minimum of 2.4V but still compatible with CMOS outputs.

Bipolar-Supply Operation

The MAX4598 operates with bipolar supplies between $\pm 2.7V$ and $\pm 6V$. The V+ and V- supplies need not be symmetrical, but their sum cannot exceed the absolute maximum rating of 13V. **Do not connect the MAX4598 V+ pin to +3V and connect the logic-level input pins to TTL logic-level signals. TTL logic-level outputs can exceed the absolute maximum ratings, causing damage to the part and/or external circuits.**

Low-Voltage, Combination Single-Ended 8-to-1/Differential 4-to-1 Multiplexer

Caution: The absolute maximum V+ to V- differential voltage is 13V. Typical “±6 Volt” or “12 Volt” supplies with ±10% tolerances can be as high as 13.2V from V+ to V-. This voltage can damage the MAX4598. Even ±5% tolerance supplies may have overshoot or noise spikes that exceed 13V.

Single-Supply Operation

The MAX4598 operates from a single supply between +2.7V and +12V when V- is connected to GND. All of the bipolar precautions must be observed. However, these parts are optimized for ±5V operation, and most AC and DC characteristics are degraded significantly when departing from ±5V. As the overall supply voltage (V+ to V-) is lowered, switching speed, on-resistance,

off-isolation, and distortion are degraded (see *Typical Operating Characteristics*).

Single-supply operation also limits signal levels and interferes with grounded signals. When V- = 0, AC signals are limited to -0.3V. Voltages below -0.3V can be clipped by the internal ESD-protection diodes, and the parts can be damaged if excessive current flows.

Power Off

When power to the MAX4598 is off (i.e., V+ = V- = 0), the Absolute Maximum Ratings still apply: neither logic-level inputs on NO_ nor signals on COM_ can exceed ±0.3V. Voltages beyond ±0.3V cause the internal ESD-protection diodes to conduct, and the parts can be damaged if excessive current flows.

Test Circuits/Timing Diagrams

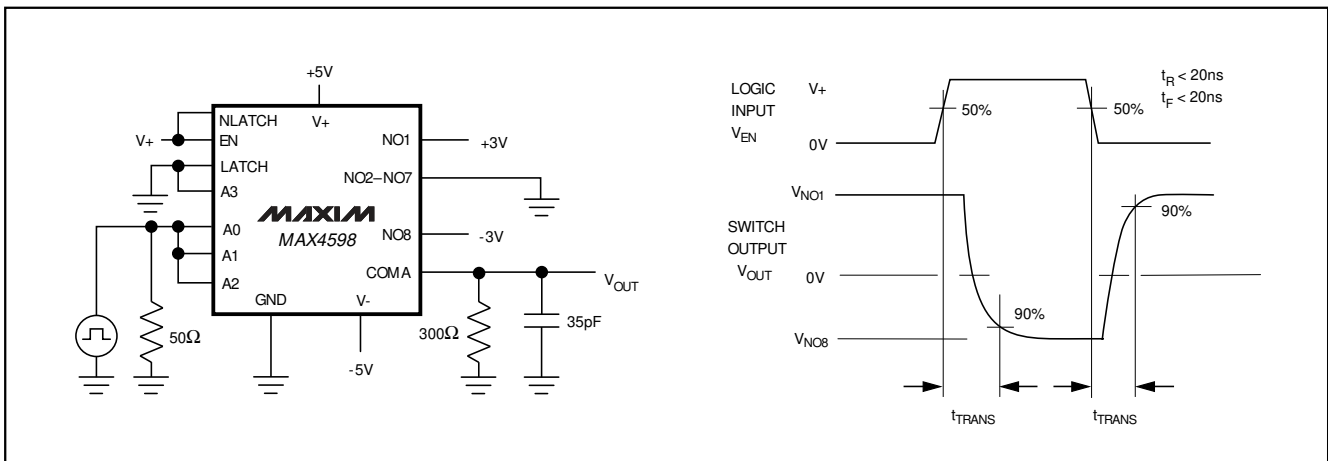

Figure 1. Transition Time

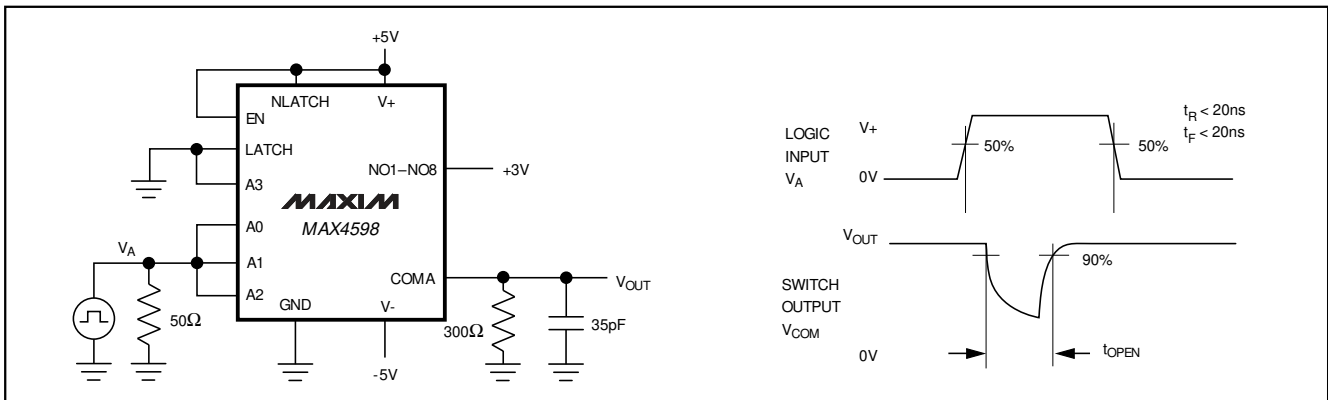

Figure 2. Break-Before-Make Interval

Low-Voltage, Combination Single-Ended 8-to-1/Differential 4-to-1 Multiplexer

Test Circuits/Timing Diagrams (continued)

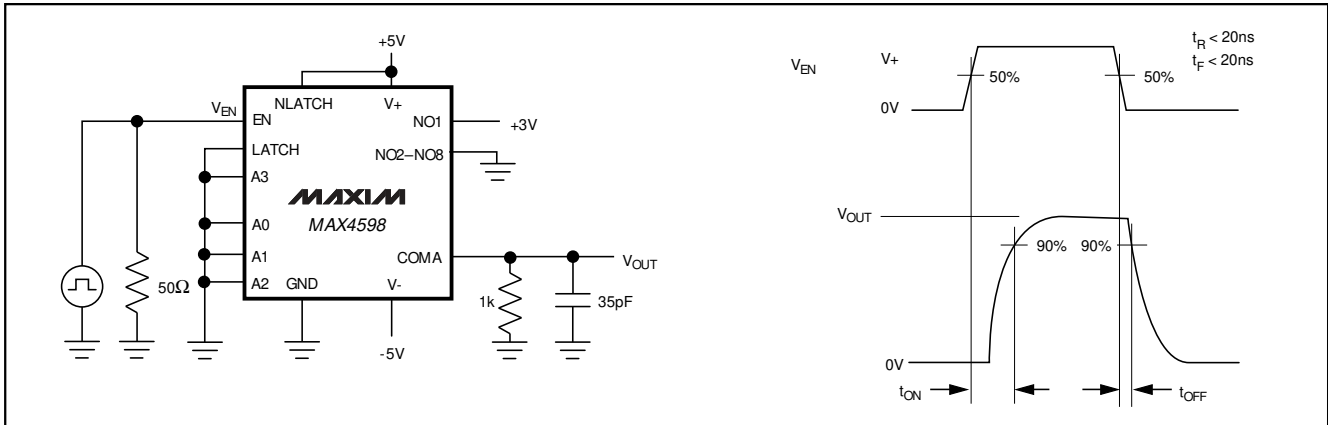

Figure 3. Enable Switching Time

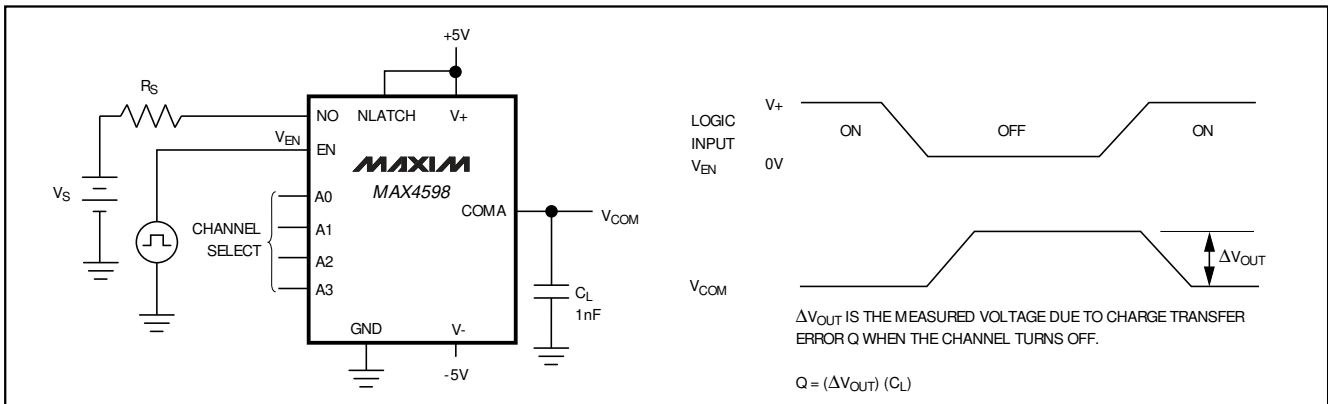

Figure 4. Charge Injection

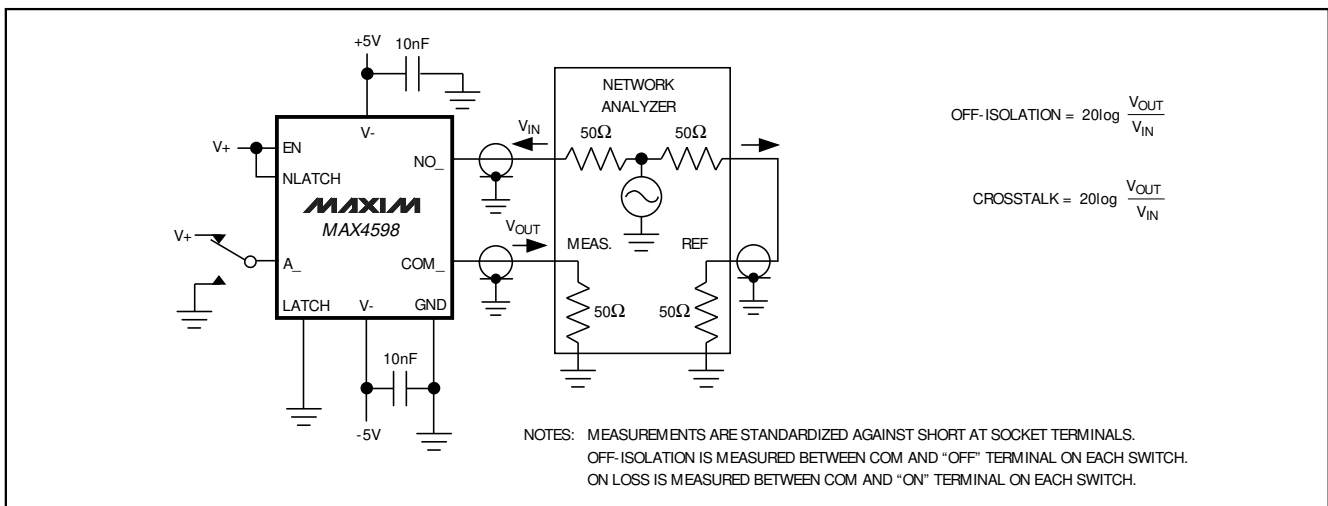

Figure 5. Off-Isolation/Crosstalk

Low-Voltage, Combination Single-Ended 8-to-1/Differential 4-to-1 Multiplexer

Test Circuits/Timing Diagrams (continued)

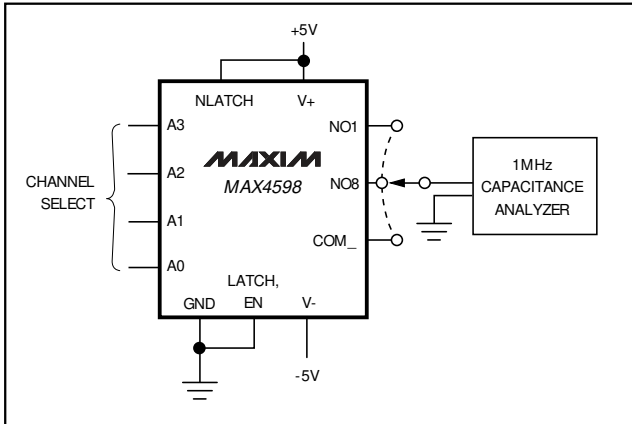

Figure 6. NO_/COM_ Capacitance

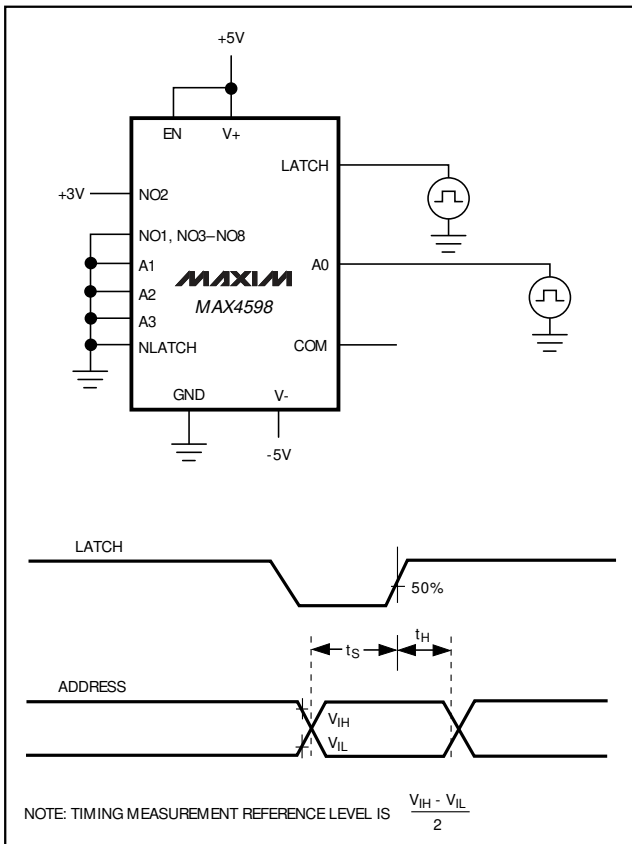
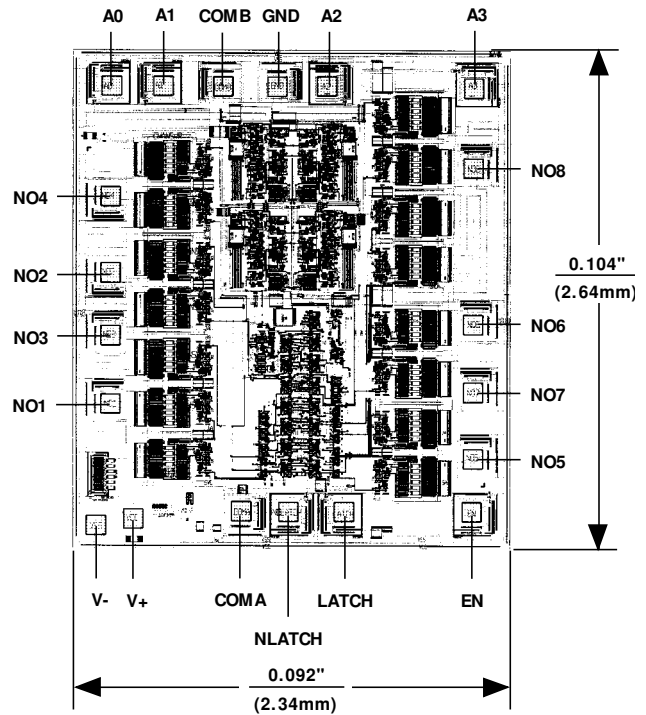

Figure 7. Setup Time, Hold Time

Chip Topography



MAX4598

TRANSISTOR COUNT: 287
SUBSTRATE CONNECTED TO V+

MAX4598

Low-Voltage, Combination Single-Ended 8-to-1/Differential 4-to-1 Multiplexer

NOTES

Maxim cannot assume responsibility for use of any circuitry other than circuitry entirely embodied in a Maxim product. No circuit patent licenses are implied. Maxim reserves the right to change the circuitry and specifications without notice at any time.

12 _____ **Maxim Integrated Products, 120 San Gabriel Drive, Sunnyvale, CA 94086 408-737-7600**