

10	9	8	7	6	5	4	3	2	1	
MATERIAL NUMBER	ENGINEERING NUMBER	MATERIAL NUMBER ON TAPE	ENGINEERING NUMBER ON TAPE	STUD SIZE	HOLE "S" ± 0.005 ± 0.03	"D" MAX	"H" ± 0.10 ± 0.25	"L" MAX	"T" REF	ID MIN
191640085	SA-221-06	191641141	SA-221-06T	#6	$\varnothing .146/3.71$	$\varnothing .32/8.1$.534/13.56	1.46/37.1	.028/0.71	.064/1.63
191640086	SA-221-08	191640419	SA-221-08T	#8	$\varnothing .173/4.39$	$\varnothing .32/8.1$.534/13.56	1.46/37.1	.028/0.71	.064/1.63
191640003	SA-221-10	191640306	SA-221-10T	#10	$\varnothing .198/5.03$	$\varnothing .32/8.1$.534/13.56	1.46/37.1	.028/0.71	.064/1.63
191640004	SA-222-14	191640844	SA-222-14T	1/4	$\varnothing .265/6.73$	$\varnothing .48/12.2$.340/8.65	1.66/42.2	.028/0.71	.064/1.63
191640435	SA-222-56	191641148	SA-222-56T	5/16	$\varnothing .328/8.33$	$\varnothing .48/12.2$.340/8.65	1.66/42.2	.028/0.71	.064/1.63
191640005	SA-226-38	191640845	SA-226-38T	3/8	$\varnothing .390/9.91$	$\varnothing .54/13.7$.328/8.33	1.95/49.5	.032/0.81	.055/1.40

(D1)

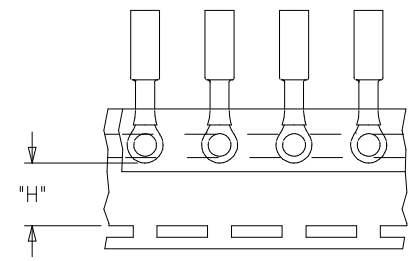
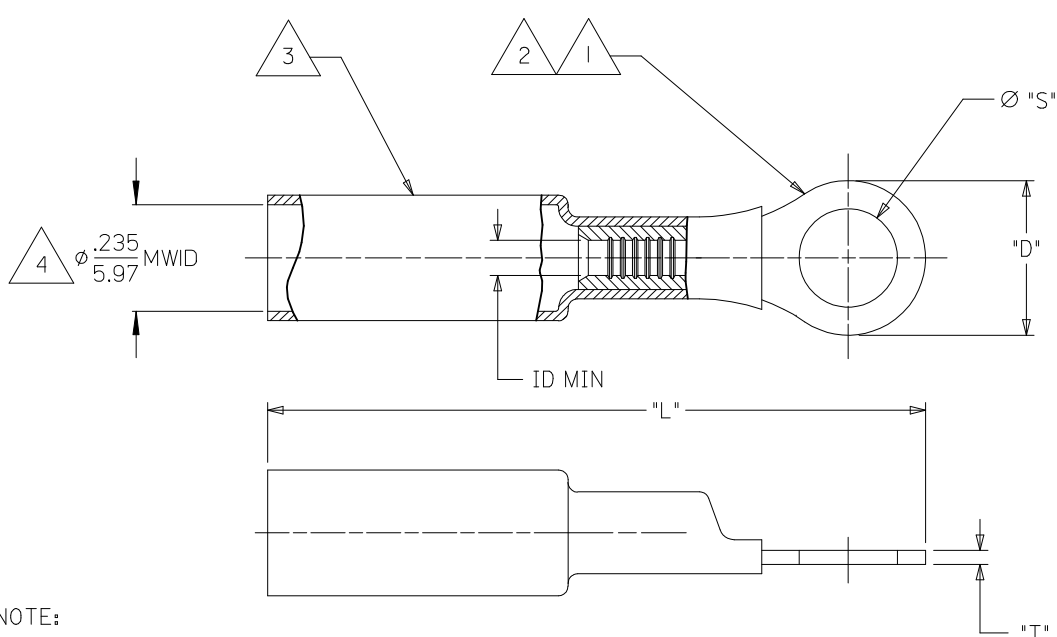

PARTS ON TAPE

SALES DRAWING

- NOTE:
- 1. TERMINAL MATERIAL: COPPER ALLOY
 - 2. FINISH: ELECTRO TIN PLATE.
 - 3. INSULATION MATERIAL: HEAT SHRINKABLE TUBING WITH HOTMELT ADHESIVE INNER LINER. COLOR: RED.
 - 4. MWID = MAXIMUM WIRE INSULATION DIAMETER.
 - 5. PARTS ARE ROHS COMPLIANT.

ADD MAT'L NUMBER EC NO: IFC2015-2076 DRAWING: GROJAS01 CHKD: JMAGNEIL APPR: JMAGNEIL	DESCRIPTION 2015/06/03 2015/06/03 2015/06/16	QUALITY SYMBOLS	GENERAL TOLERANCES (UNLESS SPECIFIED)	DIMENSION STYLE	SCALE	DESIGN UNITS	THIRD ANGLE PROJECTION		
			mm	IN/MM	---	INCH			
			4 PLACES \pm ---	INCH	DRAWN BY	DATE	TITLE		
			3 PLACES ± 0.13	$\pm .005$	BENDERLE	2005/5/14	RING TONGUE TERMINAL PERMA-SEAL NIAC 22-18 AWG		
	2 PLACES ± 0.25	$\pm .010$	CHECKED BY	DATE					
	1 PLACE \pm ---	\pm ---	HBEITZEL	2005/5/14					
	ANGULAR \pm ---	\pm ---	APPROVED BY	DATE					
			RDEROSS	2005/5/14					
			MATERIAL NO.		MATERIAL NO.				
					SD-19164-006				
			DRAFT WHERE APPLICABLE MUST REMAIN WITHIN DIMENSIONS	SEE CHART					
			SIZE						
			B						
					THIS DRAWING CONTAINS INFORMATION THAT IS PROPRIETARY TO MOLEX INCORPORATED AND SHOULD NOT BE USED WITHOUT WRITTEN PERMISSION				