

MODULAR JACKS AND PLUGS: GSX Series
Right Angle Modular Jack

Product Features

- 0.515" Height
- Snap in Board Retention Tabs
- Available with Ground Tabs
- Available Fully Shielded for Category 5 Applications
- CSA/NRTL Certified File No. LR78160
- UL File No. E134345

Performance Specifications

Materials and Finish

- Housing Material**
PBT Thermoplastic, Glass Filled, UL 94V-0 Rated, Black Color
- Shield Material**
Copper Alloy, Nickel Plated
- Contact Material**
Phosphor Bronze

Electrical Characteristics

- Insulation Resistance**
500 Megohms Min.
- Dielectric Withstanding Voltage**
1000V AC RMS for 1 Minute
- Contact Resistance**
20 milliohms Max.
- Current Rating**
1.5A
- Voltage Rating**
125V DC
- Operating Temperature**
-40°C to +85°C
- Durability Rating**
750 Mating Cycles Min.

Generated Part Number

GSX-N-88

Part Number Builder

GSX	-	N	88		
Series		Shield Option	No. of Positions & Contacts	Ground Pin Spacing	Plating Option

Series

GSX - Right Angle Jack, PCB Mount

Shield Options

- N - Non-Shielded (only with No Ground Pin Spacing)
- NS - Fully Shielded
- NS2 - Fully Shielded with Ground Tabs
- NS7 - Fully Shielded with Top & Side Ground Tabs

Number of Positions / Contacts

88 - 8 Positions / 8 Contacts

Ground Pin Spacing

- 3.05mm Ground Pin Spacing
- 3.68mm Ground Pin Spacing
- 4.57mm Ground Pin Spacing

Plating Option

- Standard
- 30µ" Gold Plating (only with fully Shielded and Ground Pin Spacing)
- 50µ" Gold Plating

Contact Kycon for *High Temperature and Other Options

GSX Series

Dimensions in mm

GSX-N-88

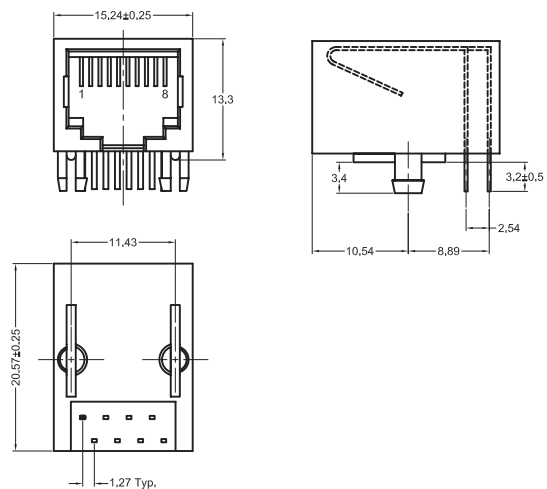

*Mins may apply