

40.0mm X 47.6mm WATER RESISTANT LED MODULES

FEATURES

- VOLTAGE: 12V DC PER MODULE
- CURRENT: 110mA PER MODULE
- LED VIEWING ANGLE (2 θ 1/2): 120°
- MODULE THICKNESS: 8mm
- PACKAGE: 50 PIECES PER REEL
- IP67

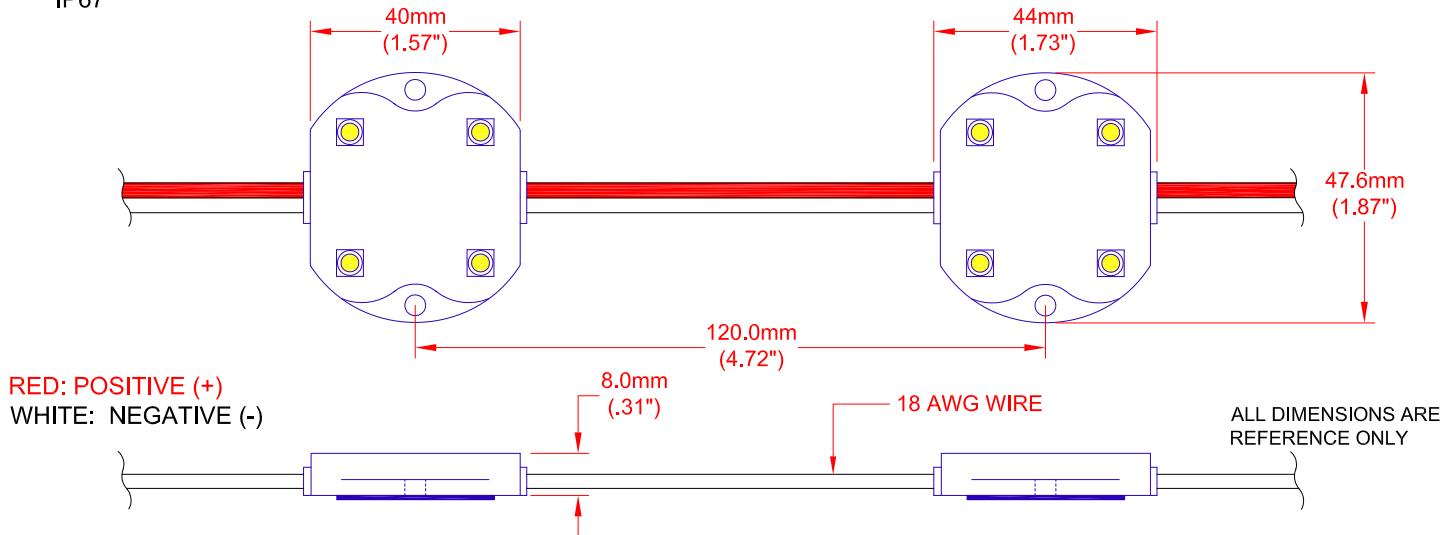
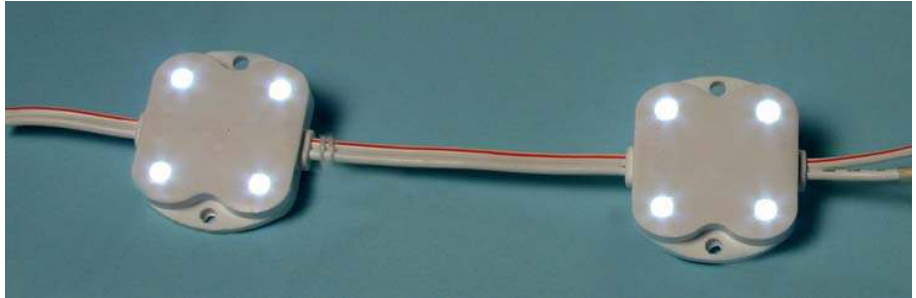

NOTES:

1. STANDARD MOUNTING INCLUDES ADHESIVE BACKING AND MOUNTING TABS FOR A #6 SCREW (SCREWS NOT INCLUDED).
2. JKL ACCESSORIES TO BE ORDERED SEPARATELY: ZPS-1235 OR ZPS-1260 POWER SUPPLIES.
3. DUE TO WIRE GAUGE USED IN THE CONSTRUCTION OF THE MODULES SERIES RUNS SHOULD BE LIMITED TO 20 FEET OR 50 MODULES.
4. POWER CONSUMPTION 4 WATTS PER FOOT.

PLEASE REFER TO JKL APPLICATION SHEET: JKL-AS-ZM-CHANNEL-LED FOR INSTALLATION AND POWER RECOMMENDATIONS.

Electrical/Optical Characteristics at TA = 25°C

Parameter	Symbol	Condition	Min	Typ	Max	Unit
Forward Voltage DC	VF	IF = 100mA	--	12	--	V
Color Temperature	TC	IF = 100mA	7500			K
Luminous Flux per Module	φV/Mod	IF = 100mA	--	52	--	lm/mod
Luminous Flux per Ft.	φV/Ft	--	--	132	--	lm/ft
Recommend Forward Current	IF(rec)	--	--	110	--	mA

Absolute Maximum Rating at TA = 25°C

Parameter	Symbol	Absolute Maximum Rating	Unit
Forward Current	IF	110	mA
Power Dissipation	PD	1.3	W
Electrostatic Discharge	ESD	800	V
Operating Temperature	Topr	-20~+70	°C
Storage Temperature	Tstg	-40~+80	°C



OBSERVE PRECAUTION FOR HANDLING ELECTROSTATIC DISCHARGE SENSITIVE DEVICES

JKL PART NO.: ZM-4047-CW

E	CORRECT NOTE	3/5/12	<p>METRIC DIMENSIONS ARE IN mm & (INCHES) TOLERANCE UNLESS OTHERWISE SPECIFIED 1 PL +/- REF. 2 PL +/- ANGLE +/-</p>	JKL COMPONENTS CORPORATION			
D	ADD APPLICATIONS NOTE	9/7/11		TITLE COOL WHITE 4 LED MODULE CHANNEL LIGHT			
C	ADD TYPE OF WIRE & CHNG NOTES	6/27/11		DRAWING NO. ZM-4047-CW			
B	ADD UL SYMBOL	4/15/11		SIZE A	FSCM NO. 55335	RELEASED DATE 3/1/11	REVISION DATE 3/5/12
A	CHANGE NOTE 3 & ELEC/OPT CHART	3/23/11		REVISION DATE 3/5/12			
	RELEASED AND CANCEL PL-1101-01	3/1/11	REV. NO. E				
REV. NO.	DESCRIPTION/ECO NUMBER	APPV'D DATE	SHEET 1 OF 1				