

THIS DRAWING IS UNPUBLISHED
 RELEASED FOR PUBLICATION
 2017
 COPYRIGHT 2017 BY - ALL RIGHTS RESERVED.

REVISIONS					
P	LTR	DESCRIPTION	DATE	DWN	APVD
	A	INITIAL RELEASE	27FEB2017	C.W	I.Y
	A1	ECN-22-136448	28JAN2022	J.S	Z.Z

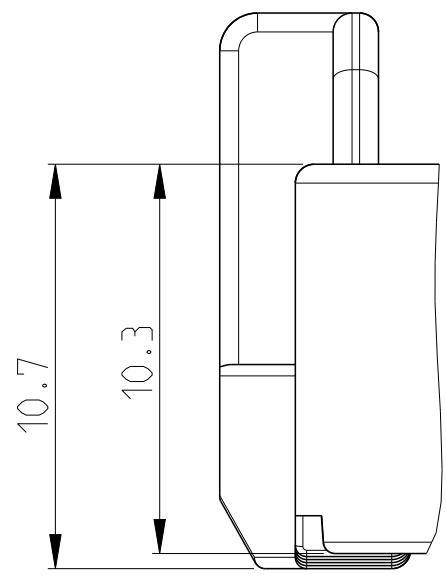

Z
5:1

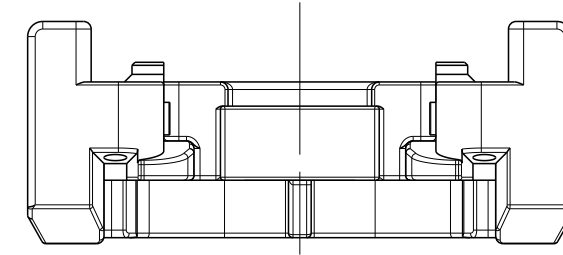
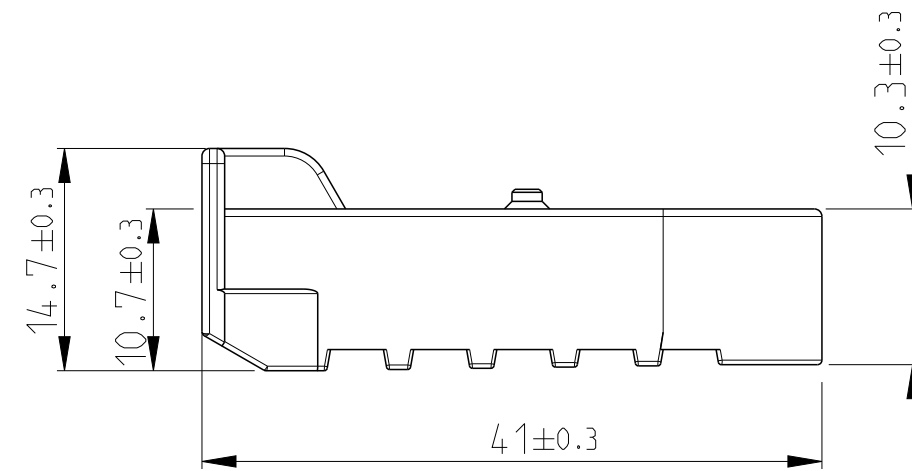
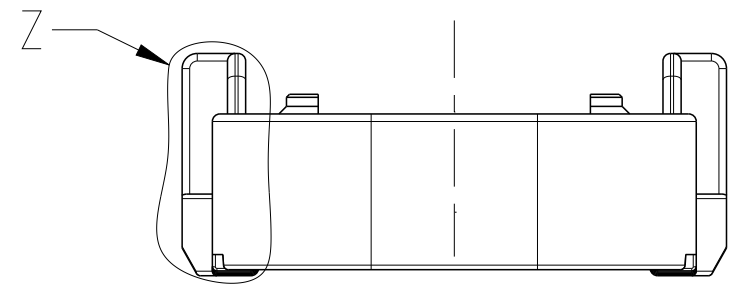
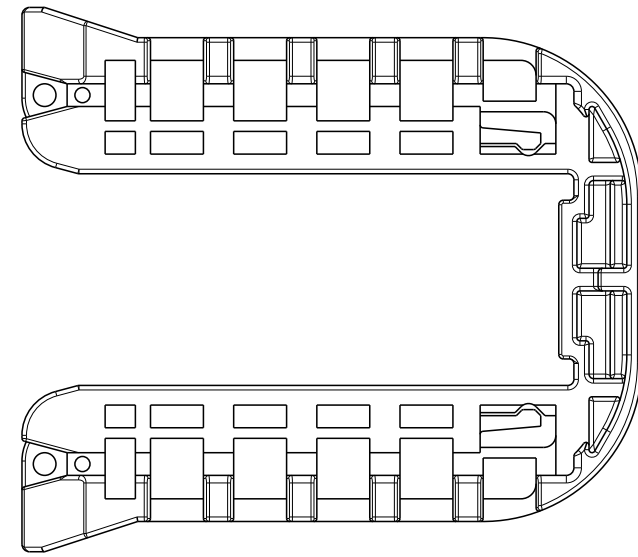

1. MATERIAL : PBT-GF20 OR EQUIVALENC RESIN.
2. PRODUCT DATE
3. LETTER-INSERTFOR THE REVISION STATUS OF THE MOULD
4. MATERIAL MARKING ACCORDING TO VDA260
5. BULK PACKAGING IN CORRUGATED BOX
6. MOULD CAVITY MARKING
7. TE LOGO
8. WARGAGE PERMITTED UP TO -1.5MM FROM NOMINAL SIZE
9. SUITALBE FOR TAB HOUISNG WITH FLANGE GROUP D, SEE PRODUCT GROUP DRAWING 1563709.
10. MARKING FOR SUITABLE SHEET METEAL THICKNESS(NOMINAL SIZE)

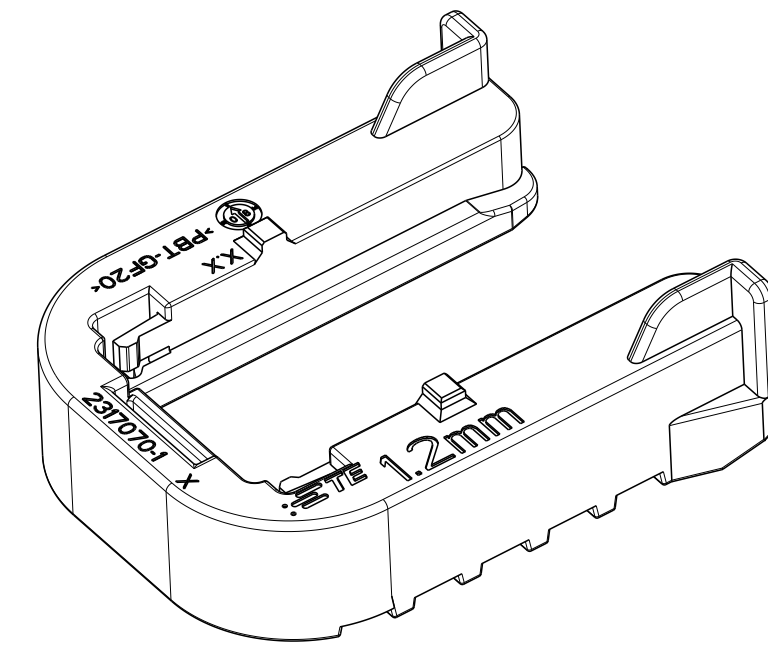
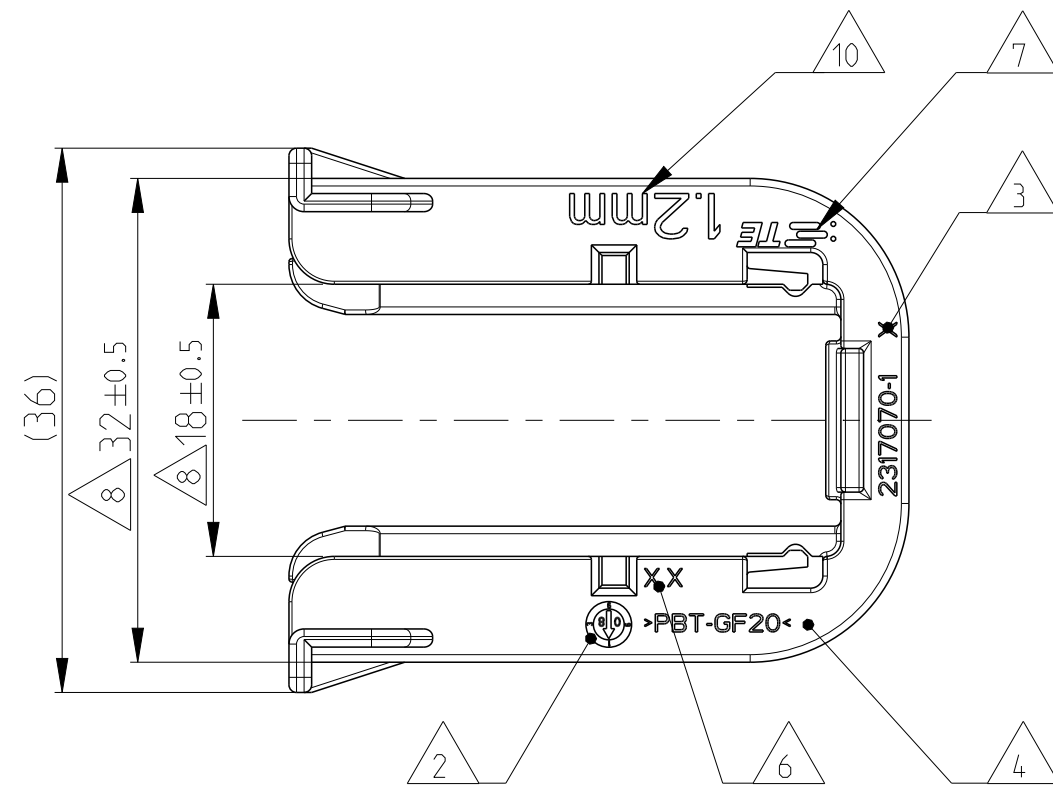

2317070-1	A	PBT-GF20/V-0	Orange	6.3	1
TE ORDER-NO.	REV.	MATERIAL	COLOUR	WEIGHT (g)	ITEM

THIS DRAWING IS A CONTROLLED DOCUMENT.		DWN C.WAN 27FEB2017	TE Connectivity														
DIMENSIONS: mm		CHK S.WANG 27FEB2017															
TOLERANCES UNLESS OTHERWISE SPECIFIED: ACC. TO DIN 16901-140		APVD J.YIN 27FEB2017	NAME SLIDE, TAB HOUSING - GROUP D FOR 1.2MM SHEETMETAL Heavy Duty Sealed Connector Series														
<table border="1"> <tr> <td>0 PLC</td> <td>±</td> </tr> <tr> <td>1 PLC</td> <td>±</td> </tr> <tr> <td>2 PLC</td> <td>±</td> </tr> <tr> <td>3 PLC</td> <td>±</td> </tr> <tr> <td>4 PLC</td> <td>±</td> </tr> <tr> <td>ANGLES</td> <td>±2°</td> </tr> </table>		0 PLC	±	1 PLC	±	2 PLC	±	3 PLC	±	4 PLC	±	ANGLES	±2°	PRODUCT SPEC 108-94020	SIZE A2		
0 PLC	±																
1 PLC	±																
2 PLC	±																
3 PLC	±																
4 PLC	±																
ANGLES	±2°																
MATERIAL SEE TABLE		APPLICATION SPEC 114-18756	CAGE CODE -	DRAWING NO. C-2317070	RESTRICTED TO -												
FINISH SEE TABLE		WEIGHT SEE TABLE	SCALE 2:1	SHEET 1 OF 1	REV A1												
CUSTOMER DRAWING																	