

SECTION W-W  
SCALE 8:1

THIS DRAWING IS A CONTROLLED DOCUMENT.		DIN T. BILLMAN 4-9-90	TE Connectivity
DIMENSIONS: INCHES		CHK R. MILLER 4-9-90	
TOLERANCES UNLESS OTHERWISE SPECIFIED:		APVD R. SMITH 4-9-90	NAME SIMM II RTANG 1.27[.050] 1.27 [.500] CL ASSY., 6.350 [.250] HEIGHT
0 PLC ± -	1 PLC ± -	PRODUCT SPEC	APPLICATION SPEC
2 PLC ± -	3 PLC ± .127(.005)	SIZE A1	CAGE CODE 00779
4 PLC ± -	ANGLES ± -	DRAWING NO C=382486	RESTRICTED TO
MATERIAL HSG:GLASS REINF	FINISH 	WEIGHT -	SCALE 4:1
CUSTOMER DRAWING		SHEET 1 OF 2	REV J1

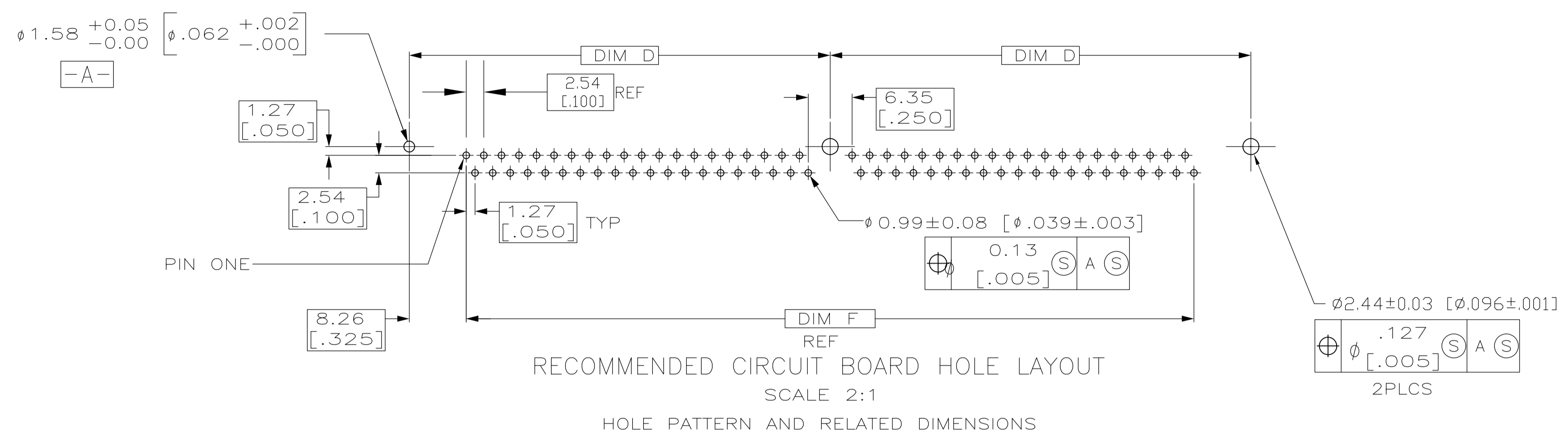

1 FOR OPTIMUM PERFORMANCE, CONTACT PAD PLATING SHOULD BE SMOOTH AND FLAT. COPPER CONTACT PADS ARE TO BE OVERPLATED WITH .00127 [.00050] MIN THK NICKEL FOLLOWED WITH 0.00254 [.000100] MIN THK TIN-LEAD PLATING.

2 0.00381 [.000150] MIN. THK TIN-LEAD OVER 0.00127 [.000050] MIN. THK NICKEL OVER ENTIRE CONTACT.

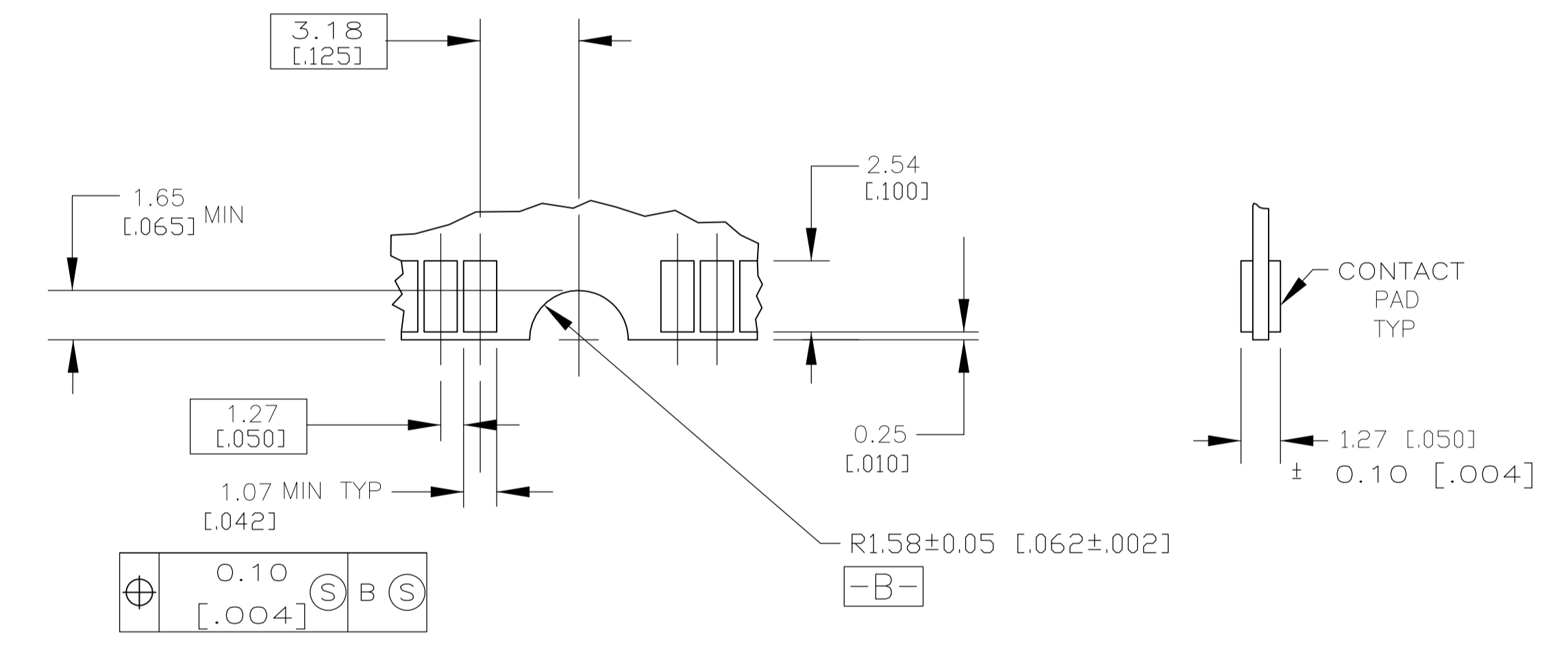
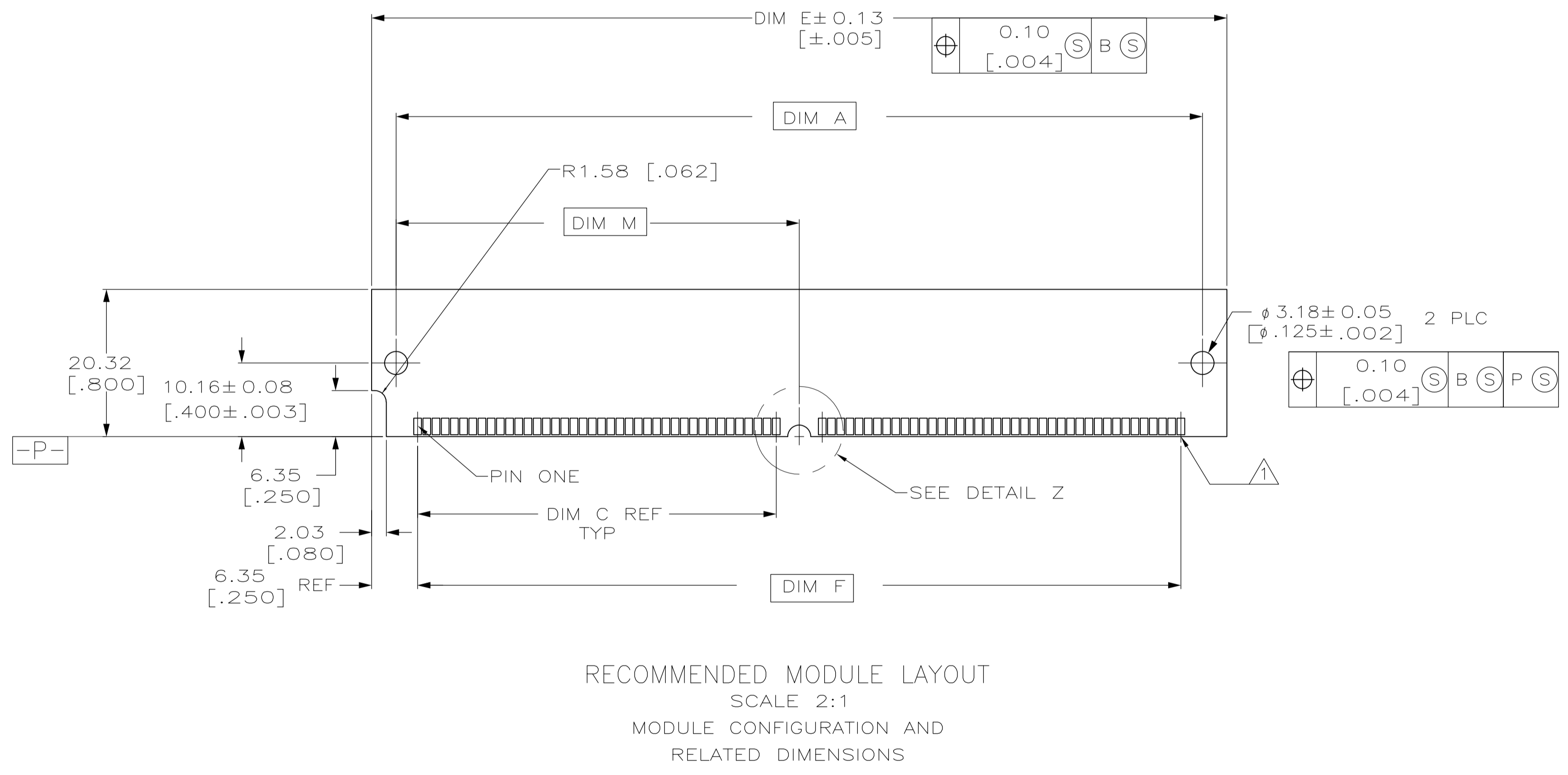

OBSOLETE	58.22 [2.292]	127.00 [5.000]	110.49 [4.350]	123.19 [4.850]	63.50 [2.500]	52.07 [2.050]	130.81 [5.150]	116.43 [4.584]	84	8-382486-4
	55.68 [2.192]	121.92 [4.800]	105.41 [4.150]	118.11 [4.650]	60.96 [2.400]	49.53 [1.950]	125.73 [4.950]	111.35 [4.384]	80	8-382486-0
	50.60 [1.992]	111.76 [4.400]	95.25 [3.750]	107.95 [4.250]	55.88 [2.200]	44.45 [1.750]	115.57 [4.550]	101.19 [3.984]	72	7-382486-2
OBSOLETE	48.06 [1.892]	106.68 [4.200]	90.17 [3.550]	102.87 [4.050]	53.34 [2.100]	41.91 [1.650]	110.49 [4.350]	96.11 [3.784]	68	6-382486-8
OBSOLETE	45.52 [1.792]	101.60 [4.000]	85.09 [3.350]	97.79 [3.850]	50.80 [2.000]	39.37 [1.550]	105.41 [4.150]	91.03 [3.584]	64	6-382486-4
OBSOLETE	30.28 [1.192]	71.12 [2.800]	54.61 [2.150]	67.31 [2.650]	35.56 [1.400]	24.13 [0.950]	74.93 [2.950]	60.55 [2.384]	40	4-382486-0
	DIM M	DIM J	DIM F	DIM E	DIM D	DIM C	DIM B	DIM A	POSN	

THIS DRAWING IS A CONTROLLED DOCUMENT.

DIMENSIONS:	TOLERANCES UNLESS OTHERWISE SPECIFIED:	0 PLC ± -	1 PLC ± -	2 PLC ± -	3 PLC ± 0.13 [.005]	4 PLC ± -	ANGLES ± -
MATERIAL	FINISH	WEIGHT	SIZE	CAGE CODE	DRAWING NO	RESTRICTED TO	
			A1	00779	382486		

STE TE Connectivity

SIMM II, RTANG,  
1.27 [.050] CL ASSY.,  
6.35 [.250] HGT

CUSTOMER DRAWING SCALE 4:1 SHEET 2 OF 2 REV J1