

TACBeam® M83526/20&/21 Qualified Expanded Beam Rugged Fiber Optic Connectors



The TACBeam® is a MIL-PRF-83526/20 & /21 qualified expanded beam rugged fiber optic connector for military and industrial applications.

TACBeam® is hermaphroditic, which allows multiple cable assemblies to connect together to support varying distance requirements. The TACBeam® connectors are available in both multimode and single mode, can support two or four channels using a common insert and will accept a wide variety of cables for any application. Sub-micron machining and measuring equipment is in the Amphenol Fiber Systems International (AFSI) facility for the manufacturing of this new expanded beam product.

AFSI designs, manufactures, markets and supports reliable and innovative fiber optic interconnect solutions that withstand the harsh environments of military, oil & gas, mining and broadcast applications. After more than two decades in business, AFSI continues to uphold its position as a global leader in fiber optic interconnect components and systems such as termini, M28876, MIL-ST, TFOCA and the TFOCA-II® connector, which AFSI developed and patented.

Features & Benefits :

- **QPL Qualified**
 - M83526/20 & /21 qualified
- **Mechanical**
 - Hermaphroditic coupling
 - Enables 'daisy-chaining' assemblies supporting varying distances
- **Single Mode and Multimode**
 - The only dual wavelength qualified connector
- **Expanded Beam**
 - Less susceptible to contaminants affecting optical performance
- **Environmental**
 - Operating temperature -46°C to + 71°C
 - 15 m water depth-mated
 - 3000 cycles mating durability
- **ROHS Compliant**
 - Hard black anodized aluminum
 - Cadmium free
 - Marine bronze & stainless steel available

Amphenol Fiber Systems International, Inc. | 1300 Central Expressway N, Suite 100 Allen, TX 75013
Phone: (214) 547-2400 | Email: sales@fibersystems.com | Website: amphenol-fsi.com

Amphenol Fiber Systems International (AFSI), a division of Amphenol Military & Aerospace Operations (AMAO), is the largest manufacturer of harsh environment fiber optic cable assemblies & connectors in the world. Visit AMAO at amphenolmao.com.

Applications :

- C4ISR Tactical Military Ground Communications
- Oil & Gas Seismic Systems
- Broadcast Systems
- Mining and Tunneling Equipment

Assembly Tooling :

No special tooling is required for the termination of this product.

Performance :

Requirement	Result
Insertion Loss, Typical	1.5 dB Multimode @ 850/1300 nm, 0.7 dB Typical 2.5 dB Single Mode @ 1310/1550 nm, 1.0 Typical
Return Loss	>34 dB unmated @ 1310/1550 nm
Mating Durability	3,000 cycles
Operating Temperature	-46°C to 71°C
Storage Temperature	-57°C to 85°C
Cyclic Temperature	-55°C/85°C
Humidity	95% RH
Immersion	15 m, water (plug & receptacle)
Shock	EIA/TIA 455-14, test condition A
Impact	EIA/TIA 455-2, method C, service class: Severe
Vibration	EIA/TIA 455-11, sinusoidal condition III (at 10 g), random condition VI (letter C) for 1.5 hours
Weight	Approximately 130 g plug & 100 g receptacle

EB4H1000 :

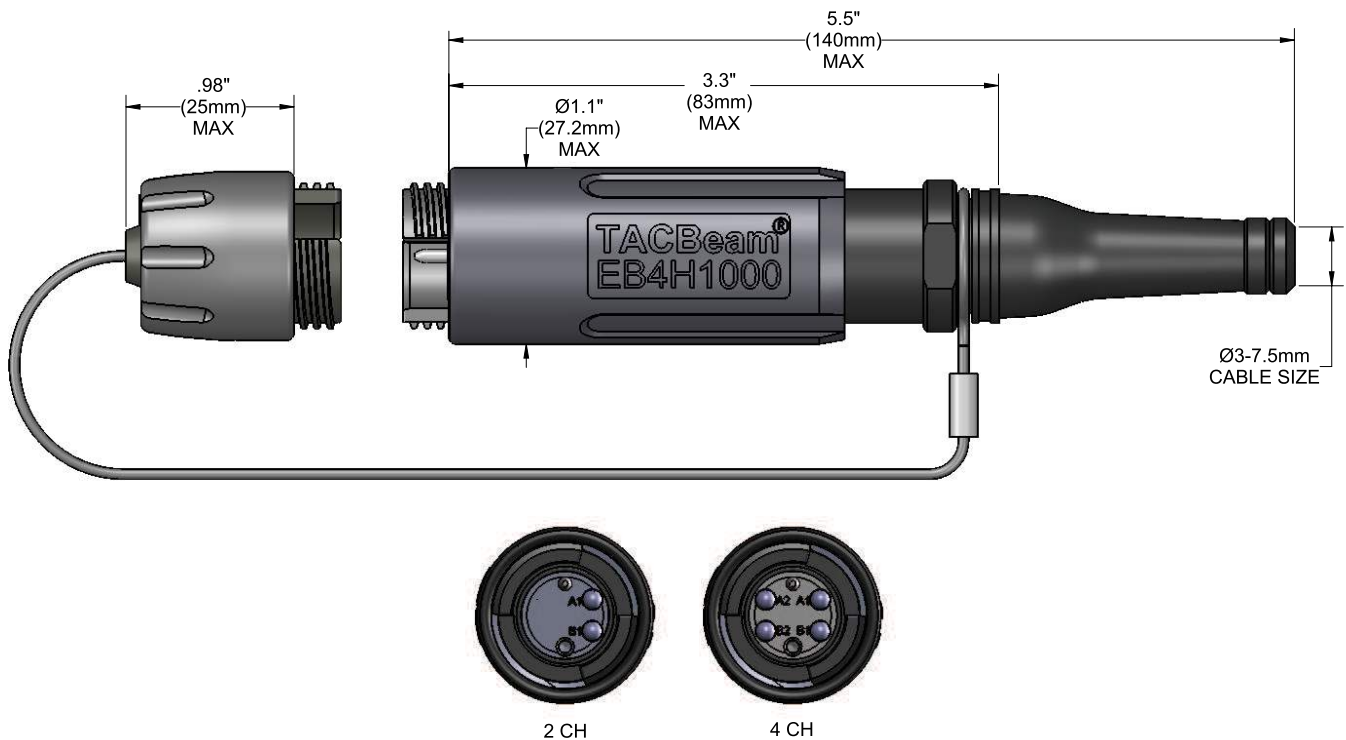

Amphenol Fiber Systems International, Inc. | 1300 Central Expressway N, Suite 100 Allen, TX 75013

Phone: (214) 547-2400 | Email: sales@fibersystems.com | Website: amphenol-fsi.com

Amphenol Fiber Systems International (AFSI), a division of Amphenol Military & Aerospace Operations (AMAO), is the largest manufacturer of harsh environment fiber optic cable assemblies & connectors in the world. Visit AMAO at amphenolmao.com.

EB4H6000 :

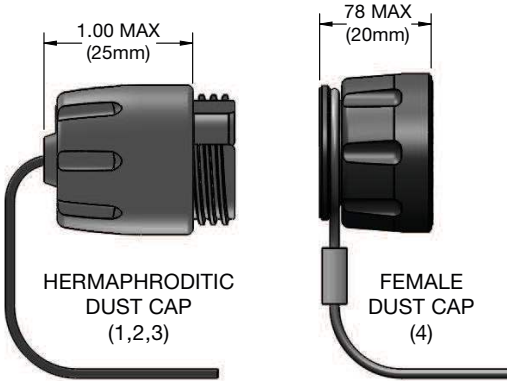

EB4H8000 :

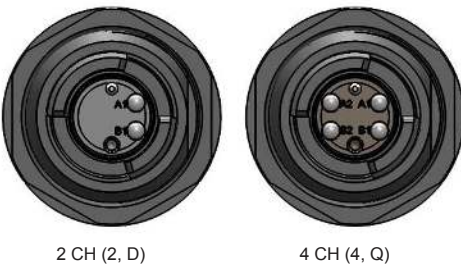
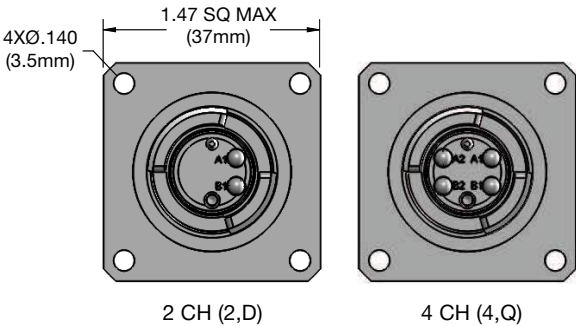
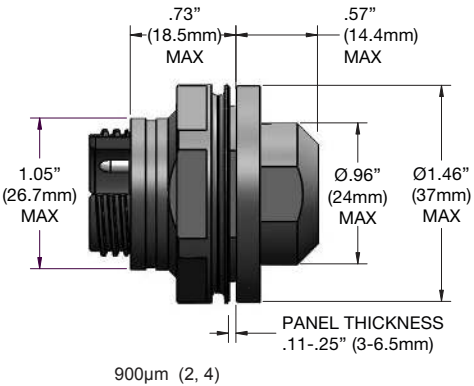
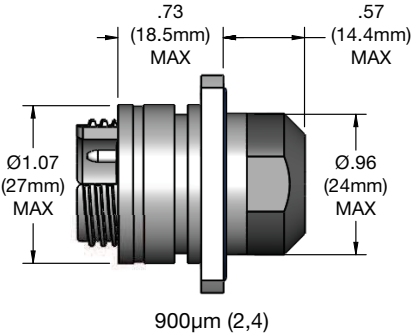
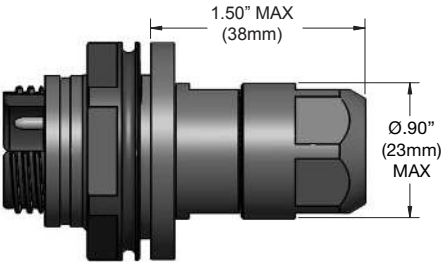
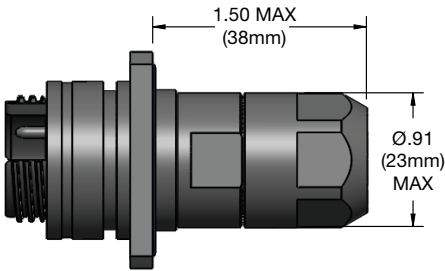
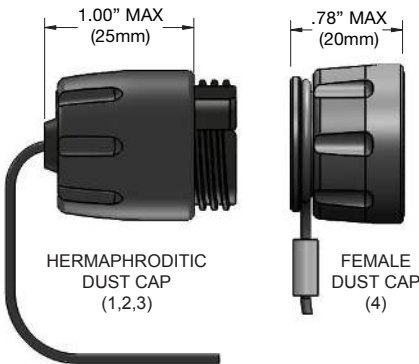

Amphenol Fiber Systems International (AFSI) :



Amphenol Fiber Systems International (AFSI) designs, manufactures, markets and supports reliable and innovative fiber optic interconnect solutions that withstand the harsh environments of military, oil & gas, mining and broadcast applications. After more than a decade in business, AFSI continues to uphold its position as a global leader in fiber optic interconnect components and systems such as termini, M28876, MIL-ST, TFOCA and the TFOCA-II® connector, which AFSI developed and patented.

AFSI has delivered millions of fiber optic connectors in more than 34 countries. Whenever there is a need for superior, cost-effective fiber optic systems and products that will stand up to demanding operating environments, you can rely on AFSI for engineering know-how, top-quality products and expert technical support.

Visit www.amphenol-fsi.com for more information.

How to Order :

For more information on how to order or to obtain a price quote on our TACBeam products, call toll free (U.S. only) at 800.472.4225, international calls please use 1.214.547.2400 or e-mail info@fibersystems.com.