

PCA9745B

16-channel SPI serial bus 57 mA/20 V constant current LED driver

Rev. 1.1 — 10 June 2020

Product data sheet

1. General description

The PCA9745B is a daisy-chain SPI-compatible 4-wire serial bus controlled 16-channel constant current LED driver optimized for dimming and blinking 57 mA Red/Green/Blue/Amber (RGBA) LEDs in amusement products. Each LED output has its own 8-bit resolution (256 steps) fixed frequency individual PWM controller that operates at 31.25 kHz with a duty cycle that is adjustable from 0 % to 100 % to allow the LED to be set to a specific brightness value. An additional 8-bit resolution (256 steps) group PWM controller has both a fixed frequency of 122 Hz and an adjustable frequency between 15 Hz to once every 16.8 seconds with a duty cycle that is adjustable from 0 % to 99.6 % that is used to either dim or blink all LEDs with the same value.

Each LED output can be off, on (no PWM control), set at its individual PWM controller value or at both individual and group PWM controller values. The PCA9745B operates with a supply voltage range of 3 V to 5.5 V and the constant current sink LED outputs allow up to 20 V for the LED supply. The output peak current is adjustable with an 8-bit linear DAC from 225 μ A to 57 mA.

Gradation control for all current sources is achieved via the 4-wire serial bus interface and allows user to ramp current automatically without MCU intervention. 8-bit DACs are available to adjust brightness levels for each LED current source. There are four selectable gradation control groups and each group has independently four registers to control ramp-up and ramp-down rate, step time, hold ON/OFF time and final hold ON output current. Two gradation operation modes are available for each group, one is single shot mode (output pattern once) and the other is continuous mode (output pattern repeat). Each channel can be set to either gradation mode or normal mode and assigned to any one of these four gradation control groups.

This device has built-in open, short load and overtemperature detection circuitry. The error information from the corresponding register can be read via the 4-wire serial bus. Additionally, a thermal shutdown feature protects the device when internal junction temperature exceeds the limit allowed for the process.

The PCA9745B device is designed to use 4-wire read/write serial bus with higher data clock frequency (up to 25 MHz).

The active LOW output enable input pin (\overline{OE}) blinks all the LED outputs and can be used to externally PWM the outputs, which is useful when multiple devices need to be dimmed or blinked together without using software control.



2. Features and benefits

- 16 LED drivers. Each output programmable at:
 - ◆ Off
 - ◆ On
 - ◆ Programmable LED brightness
 - ◆ Programmable group dimming/blinking mixed with individual LED brightness
 - ◆ Programmable LED output delay to reduce EMI and surge currents
- Gradation control for all channels
 - ◆ Each channel can assign to one of four gradation control groups
 - ◆ Programmable gradation time and rate for ramp-up and/or ramp-down operations
 - ◆ Programmable step time (6-bit) from 0.5 ms (minimum) to 512 ms (maximum)
 - ◆ Programmable hold-on time after ramp-up and hold-off time after ramp-down (3-bit) from 0 s to 6 s
 - ◆ Programmable final ramp-up and hold-on current
 - ◆ Programmable brightness current output adjustment, either linear or exponential curve
- 16 constant current output channels can sink up to 57 mA, tolerate up to 20 V when OFF
- Output current adjusted through an external resistor (R_{ext} input)
- Output current accuracy
 - ◆ ± 4 % between output channels
 - ◆ ± 6 % between PCA9745B devices
- Open/short load/overtemperature detection mode to detect individual LED errors ($R_{\text{ext}} < 3 \text{ k}\Omega$)
- 4-wire serial bus interface with 25 MHz data clock rate
- 256-step (8-bit) linear programmable brightness per LED output varying from fully off (default) to maximum brightness fully ON using a 31.25 kHz PWM signal
- 256-step group brightness control allows general dimming (using a 122 Hz PWM signal) from fully off to maximum brightness (default)
- 256-step group blinking with frequency programmable from 15 Hz to 16.8 s and duty cycle from 0 % to 99.6 %
- Active LOW Output Enable ($\overline{\text{OE}}$) input pin allows for hardware blinking and dimming of the LEDs
- 8 MHz internal oscillator requires no external components
- Internal power-on reset
- Noise filter on SDI/SCLK inputs
- No glitch on LEDn outputs on power-up
- Low standby current
- Operating power supply voltage (V_{DD}) range of 3 V to 5.5 V
- 5.5 V tolerant inputs on non-LED pins
- $-40 \text{ }^\circ\text{C}$ to $+105 \text{ }^\circ\text{C}$ operation
- ESD protection exceeds 4 kV HBM per JESD22-A114
- Latch-up testing is done to JEDEC Standard JESD78 which exceeds 100 mA
- Packages offered: HTSSOP28

3. Applications

- Amusement products
- RGB or RGBA LED drivers
- LED status information
- LED displays
- LCD backlights
- Keypad backlights for cellular phones or handheld devices
- Fade-in and fade-out for breathlight control
- Automotive lighting (PCA9745BTW/Q900)

4. Ordering information

Table 1. Ordering information

Type number	Topside mark	Package		
		Name	Description	Version
PCA9745BTW	PCA9745BTW	HTSSOP28	plastic thermal enhanced thin shrink small outline package; 28 leads; body width 4.4 mm; lead pitch 0.65 mm; exposed die pad	SOT1172-3
PCA9745BTW/Q900 ^[1]	PCA9745BTW	HTSSOP28	plastic thermal enhanced thin shrink small outline package; 28 leads; body width 4.4 mm; lead pitch 0.65 mm; exposed die pad	SOT1172-3

[1] AEC-Q100 compliant.

4.1 Ordering options

Table 2. Ordering options

Type number	Orderable part number	Package	Packing method	Minimum order quantity	Temperature
PCA9745BTW	PCA9745BTWJ	HTSSOP28	Reel 13" Q1/T1 *Standard mark SMD	2500	T _{amb} = -40 °C to +105 °C
PCA9745BTW/Q900	PCA9745BTW/Q900J	HTSSOP28	Reel 13" Q1/T1 *Standard mark SMD	2500	T _{amb} = -40 °C to +105 °C

5. Block diagram

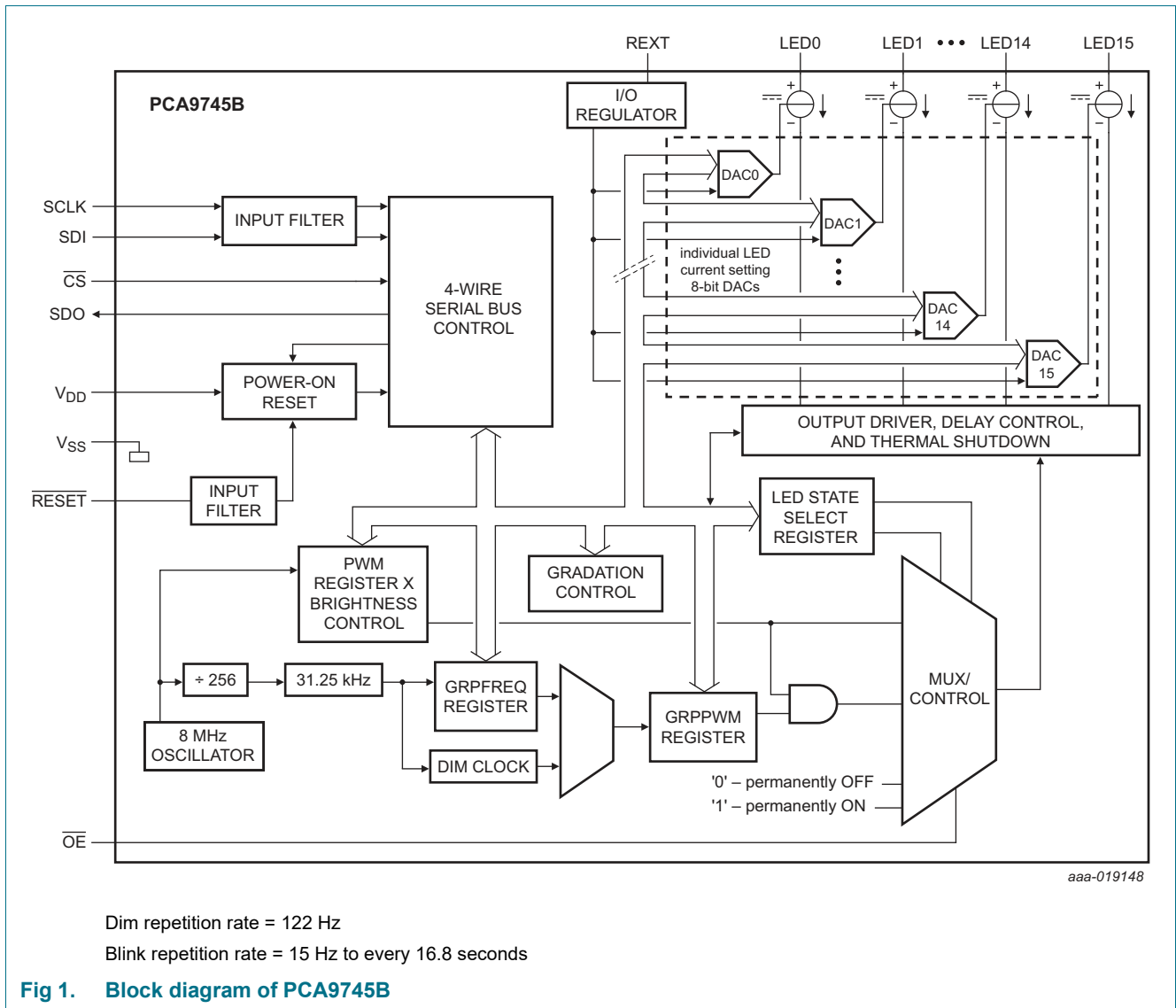

6. Pinning information

6.1 Pinning

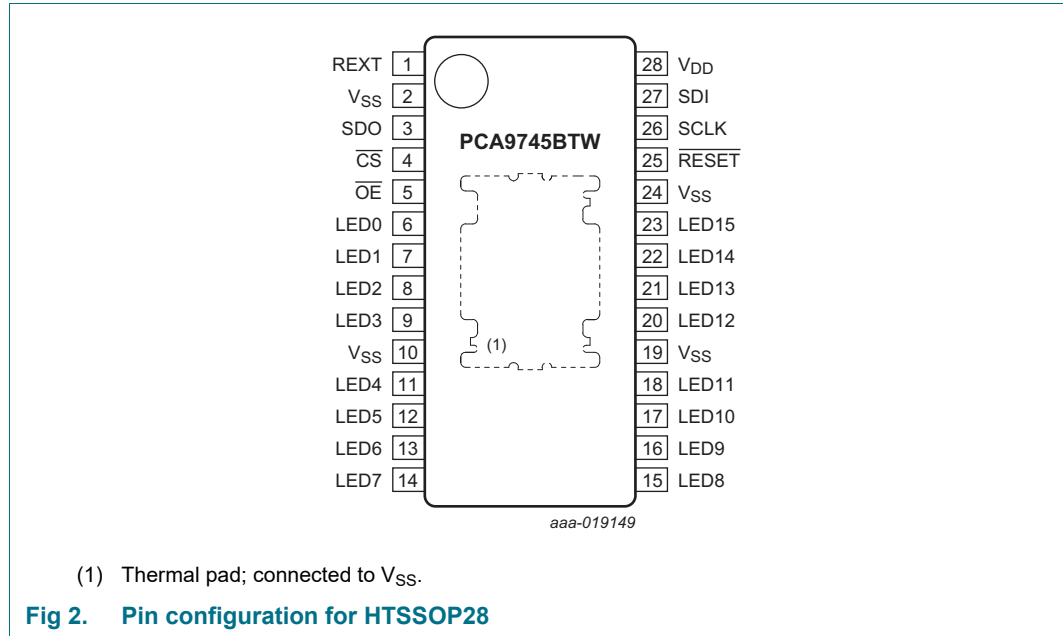

6.2 Pin description

Table 3. Pin description

Symbol	Pin	Type	Description
REXT	1	I	current set resistor input; resistor to ground
SDO	3	O	serial data output
\overline{CS}	4	I	active LOW chip select
\overline{OE}	5	I	active LOW output enable for LEDs
LED0	6	O	LED driver 0
LED1	7	O	LED driver 1
LED2	8	O	LED driver 2
LED3	9	O	LED driver 3
LED4	11	O	LED driver 4
LED5	12	O	LED driver 5
LED6	13	O	LED driver 6
LED7	14	O	LED driver 7
LED8	15	O	LED driver 8
LED9	16	O	LED driver 9
LED10	17	O	LED driver 10
LED11	18	O	LED driver 11
LED12	20	O	LED driver 12
LED13	21	O	LED driver 13

Table 3. Pin description ...continued

Symbol	Pin	Type	Description
LED14	22	O	LED driver 14
LED15	23	O	LED driver 15
$\overline{\text{RESET}}$	25	I	active LOW reset input with external 10 k Ω pull-up resistor
SCLK	26	I	serial clock line
SDI	27	I	serial data input
V _{SS}	2, 10, 19, 24 [1]	ground	supply ground
V _{DD}	28	power supply	supply voltage

[1] HTSSOP28 package supply ground is connected to both V_{SS} pins and exposed center pad. V_{SS} pins must be connected to supply ground for proper device operation. For enhanced thermal, electrical, and board level performance, the exposed pad needs to be soldered to the board using a corresponding thermal pad on the board and for proper heat conduction through the board, thermal vias need to be incorporated in the printed-circuit board in the thermal pad region.

7. Functional description

Refer to [Figure 1 “Block diagram of PCA9745B”](#).

7.1 Register address and data

Following a chip select ($\overline{\text{CS}}$) asserted condition (from HIGH to LOW), the data transfers are (16 × n) bits wide (where ‘n’ is the number of slaves in the chain) with MSB transferred first. The first 7 bits are the address of the register to be accessed. The eighth bit indicates the types of access — read (= 1) or write (= 0). The second group of 8 bits consists of data as shown in [Figure 3](#).

See [Section 8 “Characteristics of the 4-wire SPI serial-bus interface”](#) for more detail.

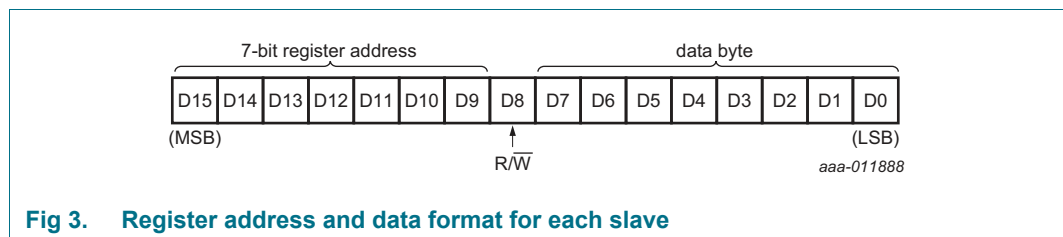

Fig 3. Register address and data format for each slave

7.2 Register definitions

Table 4. Register summary

Register number (hex)	D6	D5	D4	D3	D2	D1	D0	Name	Type	Function
00h	0	0	0	0	0	0	0	MODE1	read/write	Mode register 1
01h	0	0	0	0	0	0	1	MODE2	read/write	Mode register 2
02h	0	0	0	0	0	1	0	LEDOUT0	read/write	LED output state 0
03h	0	0	0	0	0	1	1	LEDOUT1	read/write	LED output state 1
04h	0	0	0	0	1	0	0	LEDOUT2	read/write	LED output state 2
05h	0	0	0	0	1	0	1	LEDOUT3	read/write	LED output state 3

Table 4. Register summary ...continued

Register number (hex)	D6	D5	D4	D3	D2	D1	D0	Name	Type	Function
06h	0	0	0	0	1	1	0	GRPPWM	read/write	group duty cycle control
07h	0	0	0	0	1	1	1	GRPFREQ	read/write	group frequency
08h	0	0	0	1	0	0	0	PWM0	read/write	brightness control LED0
09h	0	0	0	1	0	0	1	PWM1	read/write	brightness control LED1
0Ah	0	0	0	1	0	1	0	PWM2	read/write	brightness control LED2
0Bh	0	0	0	1	0	1	1	PWM3	read/write	brightness control LED3
0Ch	0	0	0	1	1	0	0	PWM4	read/write	brightness control LED4
0Dh	0	0	0	1	1	0	1	PWM5	read/write	brightness control LED5
0Eh	0	0	0	1	1	1	0	PWM6	read/write	brightness control LED6
0Fh	0	0	0	1	1	1	1	PWM7	read/write	brightness control LED7
10h	0	0	1	0	0	0	0	PWM8	read/write	brightness control LED8
11h	0	0	1	0	0	0	1	PWM9	read/write	brightness control LED9
12h	0	0	1	0	0	1	0	PWM10	read/write	brightness control LED10
13h	0	0	1	0	0	1	1	PWM11	read/write	brightness control LED11
14h	0	0	1	0	1	0	0	PWM12	read/write	brightness control LED12
15h	0	0	1	0	1	0	1	PWM13	read/write	brightness control LED13
16h	0	0	1	0	1	1	0	PWM14	read/write	brightness control LED14
17h	0	0	1	0	1	1	1	PWM15	read/write	brightness control LED15
18h	0	0	1	1	0	0	0	IREF0	read/write	output gain control register 0
19h	0	0	1	1	0	0	1	IREF1	read/write	output gain control register 1
1Ah	0	0	1	1	0	1	0	IREF2	read/write	output gain control register 2
1Bh	0	0	1	1	0	1	1	IREF3	read/write	output gain control register 3
1Ch	0	0	1	1	1	0	0	IREF4	read/write	output gain control register 4
1Dh	0	0	1	1	1	0	1	IREF5	read/write	output gain control register 5
1Eh	0	0	1	1	1	1	0	IREF6	read/write	output gain control register 6
1Fh	0	0	1	1	1	1	1	IREF7	read/write	output gain control register 7
20h	0	1	0	0	0	0	0	IREF8	read/write	output gain control register 8
21h	0	1	0	0	0	0	1	IREF9	read/write	output gain control register 9
22h	0	1	0	0	0	1	0	IREF10	read/write	output gain control register 10
23h	0	1	0	0	0	1	1	IREF11	read/write	output gain control register 11
24h	0	1	0	0	1	0	0	IREF12	read/write	output gain control register 12
25h	0	1	0	0	1	0	1	IREF13	read/write	output gain control register 13
26h	0	1	0	0	1	1	0	IREF14	read/write	output gain control register 14
27h	0	1	0	0	1	1	1	IREF15	read/write	output gain control register 15
28h	0	1	0	1	0	0	0	RAMP_RATE_GRP0	read/write	ramp enable and rate control for group 0
29h	0	1	0	1	0	0	1	STEP_TIME_GRP0	read/write	step time control for group 0
2Ah	0	1	0	1	0	1	0	HOLD_CNTL_GRP0	read/write	hold ON/OFF time control for group 0
2Bh	0	1	0	1	0	1	1	IREF_GRP0	read/write	output gain control for group 0

Table 4. Register summary ...continued

Register number (hex)	D6	D5	D4	D3	D2	D1	D0	Name	Type	Function
2Ch	0	1	0	1	1	0	0	RAMP_RATE_GRP1	read/write	ramp enable and rate control for group 1
2Dh	0	1	0	1	1	0	1	STEP_TIME_GRP1	read/write	step time control for group 1
2Eh	0	1	0	1	1	1	0	HOLD_CNTL_GRP1	read/write	hold ON/OFF time control for group 1
2Fh	0	1	0	1	1	1	1	IREF_GRP1	read/write	output gain control for group 1
30h	0	1	1	0	0	0	0	RAMP_RATE_GRP2	read/write	ramp enable and rate control for group 2
31h	0	1	1	0	0	0	1	STEP_TIME_GRP2	read/write	step time control for group 2
32h	0	1	1	0	0	1	0	HOLD_CNTL_GRP2	read/write	hold ON/OFF time control for group 2
33h	0	1	1	0	0	1	1	IREF_GRP2	read/write	output gain control for group 2
34h	0	1	1	0	1	0	0	RAMP_RATE_GRP3	read/write	ramp enable and rate control for group 3
35h	0	1	1	0	1	0	1	STEP_TIME_GRP3	read/write	step time control for group 3
36h	0	1	1	0	1	1	0	HOLD_CNTL_GRP3	read/write	hold ON/OFF time control for group 3
37h	0	1	1	0	1	1	1	IREF_GRP3	read/write	output gain control for group 3
38h	0	1	1	1	0	0	0	GRAD_MODE_SEL0	read/write	gradation mode select register for channel 7 to channel 0
39h	0	1	1	1	0	0	1	GRAD_MODE_SEL1	read/write	gradation mode select register for channel 15 to channel 8
3Ah	0	1	1	1	0	1	0	GRAD_GRP_SEL0	read/write	gradation group select for channel 3 to channel 0
3Bh	0	1	1	1	0	1	1	GRAD_GRP_SEL1	read/write	gradation group select for channel 7 to channel 4
3Ch	0	1	1	1	1	0	0	GRAD_GRP_SEL2	read/write	gradation group select for channel 11 to channel 8
3Dh	0	1	1	1	1	0	1	GRAD_GRP_SEL3	read/write	gradation group select for channel 15 to channel 12
3Eh	0	1	1	1	1	1	0	GRAD_CNTL	read/write	gradation control register for all four groups
3Fh	0	1	1	1	1	1	1	OFFSET	read/write	Offset/delay on LEDn outputs
40h	1	0	0	0	0	0	0	PWMALL	write only	brightness control for all LEDn
41h	1	0	0	0	0	0	1	IREFALL	write only	output gain control for all registers IREF0 to IREF15
42h	1	0	0	0	0	1	0	EFLAG0	read only	output error flag 0
43h	1	0	0	0	0	1	1	EFLAG1	read only	output error flag 1
44h	1	0	0	0	1	0	0	EFLAG2	read only	output error flag 2
45h	1	0	0	0	1	0	1	EFLAG3	read only	output error flag 3
46h	1	0	0	0	1	1	0			
to	:	:	:	:	:	:	:	reserved ^[1]	read only	not used
7Fh	1	1	1	1	1	1	1			

[1] Reserved registers should not be written to and will always read back as zeros.

7.2.1 MODE1 — Mode register 1

Table 5. MODE1 - Mode register 1 (address 00h) bit description

Legend: * default value.

Bit	Symbol	Access	Value	Description
7	-	read only	0*	reserved
6	-	R/W	0*	reserved
5	-	R/W	0*	reserved
4	SLEEP	R/W	0*	Normal mode ^[1] .
			1	Low-power mode. Oscillator off ^{[2][3]} .
3	-	R/W	0*	reserved
2	-	R/W	0*	reserved
1	-	R/W	0*	reserved
0	-	R/W	0*	reserved

[1] It takes 500 μ s max. for the oscillator to be up and running once SLEEP bit has been set to logic 0. Timings on LEDn outputs are not guaranteed if PWMx, GRPPWM or GRPFREQ registers are accessed within the 500 μ s window.

[2] No blinking, dimming or gradation control is possible when the oscillator is off.

[3] The device must be reset if the LED driver output state is set to LDRx=11 after the device is set back to Normal mode.

7.2.2 MODE2 — Mode register 2

Table 6. MODE2 - Mode register 2 (address 01h) bit description

Legend: * default value.

Bit	Symbol	Access	Value	Description
7	OVERTEMP	read only	0*	O.K.
			1	overtemperature condition
6	ERROR	read only	0*	no error at LED outputs
			1	any open or short-circuit detected in error flag registers (EFLAGn)
5	DMBLNK	R/W	0*	group control = dimming
			1	group control = blinking
4	CLRERR	write only	0*	self clear after write '1'
			1	Write '1' to clear all error status bits in EFLAGn register and ERROR (bit 6). The EFLAGn and ERROR bit will set to '1' if open or short-circuit is detected again.
3	-	R/W	0*	reserved
2	EXP_EN	R/W	0*	linear adjustment for gradation control
			1	exponential adjustment for gradation control
1	-	read only	0*	reserved
0	-	read only	1*	reserved

Brightness adjustment for gradation control is either linear or exponential by setting the EXP_EN bit as shown in [Figure 4](#). When EXP_EN = 0, linear adjustment scale is used. When EXP_EN = 1, exponential scale is used.

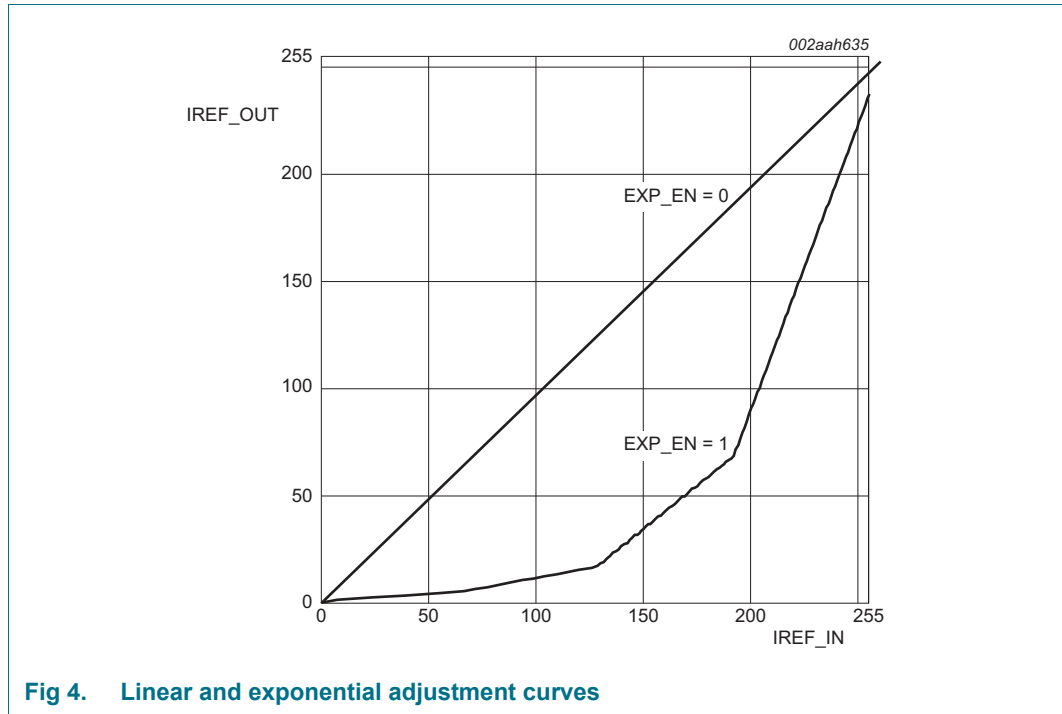

7.2.3 LEDOUT0 to LEDOUT3, LED driver output state

Table 7. LEDOUT0 to LEDOUT3 - LED driver output state registers (address 02h to 05h) bit description

Legend: * default value.

Address	Register	Bit	Symbol	Access	Value	Description
02h	LEDOUT0	7:6	LDR3	R/W	10*	LED3 output state control
		5:4	LDR2	R/W	10*	LED2 output state control
		3:2	LDR1	R/W	10*	LED1 output state control
		1:0	LDR0	R/W	10*	LED0 output state control
03h	LEDOUT1	7:6	LDR7	R/W	10*	LED7 output state control
		5:4	LDR6	R/W	10*	LED6 output state control
		3:2	LDR5	R/W	10*	LED5 output state control
		1:0	LDR4	R/W	10*	LED4 output state control
04h	LEDOUT2	7:6	LDR11	R/W	10*	LED11 output state control
		5:4	LDR10	R/W	10*	LED10 output state control
		3:2	LDR9	R/W	10*	LED9 output state control
		1:0	LDR8	R/W	10*	LED8 output state control
05h	LEDOUT3	7:6	LDR15	R/W	10*	LED15 output state control
		5:4	LDR14	R/W	10*	LED14 output state control
		3:2	LDR13	R/W	10*	LED13 output state control
		1:0	LDR12	R/W	10*	LED12 output state control

LDRx = 00 — LED driver x is off (x = 0 to 15).

LDRx = 01 — LED driver x is fully on (individual brightness and group dimming/blinking not controlled). The \overline{OE} pin can be used as external dimming/blinking control in this state.

LDRx = 10 — LED driver x individual brightness can be controlled through its PWMx register (default power-up state) or PWMALL register for all LEDn outputs.

LDRx = 11 — LED driver x individual brightness and group dimming/blinking can be controlled through its PWMx register and the GRPPWM registers.

Remark: Setting the device in low power mode while being on group dimming/blinking mode (LDRx = 11) may cause the LED output state to be in an unknown state after the device is set back to normal mode. The device must be reset and all register values reprogrammed.

7.2.4 GRPPWM, group duty cycle control

Table 8. GRPPWM - Group brightness control register (address 06h) bit description

Legend: * default value

Address	Register	Bit	Symbol	Access	Value	Description
06h	GRPPWM	7:0	GDC[7:0]	R/W	1111 1111*	GRPPWM register

When DMBLNK bit (MODE2 register) is programmed with logic 0, a 122 Hz fixed frequency signal is superimposed with the 31.25 kHz individual brightness control signal. GRPPWM is then used as a global brightness control allowing the LED outputs to be dimmed with the same value. The value in GRPFREQ is then a 'Don't care'.

General brightness for the 16 outputs is controlled through 255 linear steps from 00h (0 % duty cycle = LED output off) to FFh (99.6 % duty cycle = maximum brightness). Applicable to LED outputs programmed with LDRx = 11 (LEDOUT0 to LEDOUT3 registers).

When DMBLNK bit is programmed with logic 1, GRPPWM and GRPFREQ registers define a global blinking pattern, where GRPFREQ contains the blinking period (from 67 ms to 16.8 s) and GRPPWM the duty cycle (ON/OFF ratio in %).

$$duty\ cycle = \frac{GDC[7:0]}{256} \tag{1}$$

7.2.5 GRPFREQ, group frequency

Table 9. GRPFREQ - Group frequency register (address 07h) bit description
Legend: * default value.

Address	Register	Bit	Symbol	Access	Value	Description
07h	GRPFREQ	7:0	GFRQ[7:0]	R/W	0000 0000*	GRPFREQ register

GRPFREQ is used to program the global blinking period when DMBLNK bit (MODE2 register) is equal to 1. Value in this register is a ‘Don’t care’ when DMBLNK = 0. Applicable to LED outputs programmed with LDRx = 11 (LEDOUT0 to LEDOUT3 registers).

Blinking period is controlled through 256 linear steps from 00h (67 ms, frequency 15 Hz) to FFh (16.8 s).

$$global\ blinking\ period = \frac{GFRO[7:0] + 1}{15.26} (s) \tag{2}$$

7.2.6 PWM0 to PWM15, individual brightness control

Table 10. PWM0 to PWM15 - PWM registers 0 to 15 (address 08h to 17h) bit description
Legend: * default value.

Address	Register	Bit	Symbol	Access	Value	Description
08h	PWM0	7:0	IDC0[7:0]	R/W	0000 0000*	PWM0 Individual Duty Cycle
09h	PWM1	7:0	IDC1[7:0]	R/W	0000 0000*	PWM1 Individual Duty Cycle
0Ah	PWM2	7:0	IDC2[7:0]	R/W	0000 0000*	PWM2 Individual Duty Cycle
0Bh	PWM3	7:0	IDC3[7:0]	R/W	0000 0000*	PWM3 Individual Duty Cycle
0Ch	PWM4	7:0	IDC4[7:0]	R/W	0000 0000*	PWM4 Individual Duty Cycle
0Dh	PWM5	7:0	IDC5[7:0]	R/W	0000 0000*	PWM5 Individual Duty Cycle
0Eh	PWM6	7:0	IDC6[7:0]	R/W	0000 0000*	PWM6 Individual Duty Cycle
0Fh	PWM7	7:0	IDC7[7:0]	R/W	0000 0000*	PWM7 Individual Duty Cycle
10h	PWM8	7:0	IDC8[7:0]	R/W	0000 0000*	PWM8 Individual Duty Cycle
11h	PWM9	7:0	IDC9[7:0]	R/W	0000 0000*	PWM9 Individual Duty Cycle
12h	PWM10	7:0	IDC10[7:0]	R/W	0000 0000*	PWM10 Individual Duty Cycle
13h	PWM11	7:0	IDC11[7:0]	R/W	0000 0000*	PWM11 Individual Duty Cycle
14h	PWM12	7:0	IDC12[7:0]	R/W	0000 0000*	PWM12 Individual Duty Cycle

Table 10. PWM0 to PWM15 - PWM registers 0 to 15 (address 08h to 17h) bit description
...continued

Address	Register	Bit	Symbol	Access	Value	Description
15h	PWM13	7:0	IDC13[7:0]	R/W	0000 0000*	PWM13 Individual Duty Cycle
16h	PWM14	7:0	IDC14[7:0]	R/W	0000 0000*	PWM14 Individual Duty Cycle
17h	PWM15	7:0	IDC15[7:0]	R/W	0000 0000*	PWM15 Individual Duty Cycle

A 31.25 kHz fixed frequency signal is used for each output. Duty cycle is controlled through 255 linear steps from 00h (0 % duty cycle = LED output off) to FEh (99.2 % duty cycle = LED output at maximum brightness) and FFh (100 % duty cycle = LED output completed ON). Applicable to LED outputs programmed with LDRx = 10 or 11 (LEDOUT0 to LEDOUT3 registers).

$$duty\ cycle = \frac{IDC_x[7:0]}{256} \tag{3}$$

Remark: The first lower end 8 steps of PWM and the last (higher end) steps of PWM will not have effective brightness control of LEDs due to edge rate control of LED output pins.

7.2.7 IREF0 to IREF15, LED output current value registers

These registers reflect the gain settings for output current for LED0 to LED15.

Table 11. IREF0 to IREF15 - LED output gain control registers (address 18h to 27h) bit description

Legend: * default value.

Address	Register	Bit	Access	Value	Description
18h	IREF0	7:0	R/W	00h*	LED0 output current setting
19h	IREF1	7:0	R/W	00h*	LED1 output current setting
1Ah	IREF2	7:0	R/W	00h*	LED2 output current setting
1Bh	IREF3	7:0	R/W	00h*	LED3 output current setting
1Ch	IREF4	7:0	R/W	00h*	LED4 output current setting
1Dh	IREF5	7:0	R/W	00h*	LED5 output current setting
1Eh	IREF6	7:0	R/W	00h*	LED6 output current setting
1Fh	IREF7	7:0	R/W	00h*	LED7 output current setting
20h	IREF8	7:0	R/W	00h*	LED8 output current setting
21h	IREF9	7:0	R/W	00h*	LED9 output current setting
22h	IREF10	7:0	R/W	00h*	LED10 output current setting
23h	IREF11	7:0	R/W	00h*	LED11 output current setting
24h	IREF12	7:0	R/W	00h*	LED12 output current setting
25h	IREF13	7:0	R/W	00h*	LED13 output current setting
26h	IREF14	7:0	R/W	00h*	LED14 output current setting
27h	IREF15	7:0	R/W	00h*	LED15 output current setting

7.2.8 Gradation control

Gradation control is designed to use four independent groups of registers to program the full cycle of the gradation timing to implement on each selected channel. Each group has four registers to define the ramp rate, step time, hold ON/OFF time, and final hold ON current, as shown in [Figure 5](#).

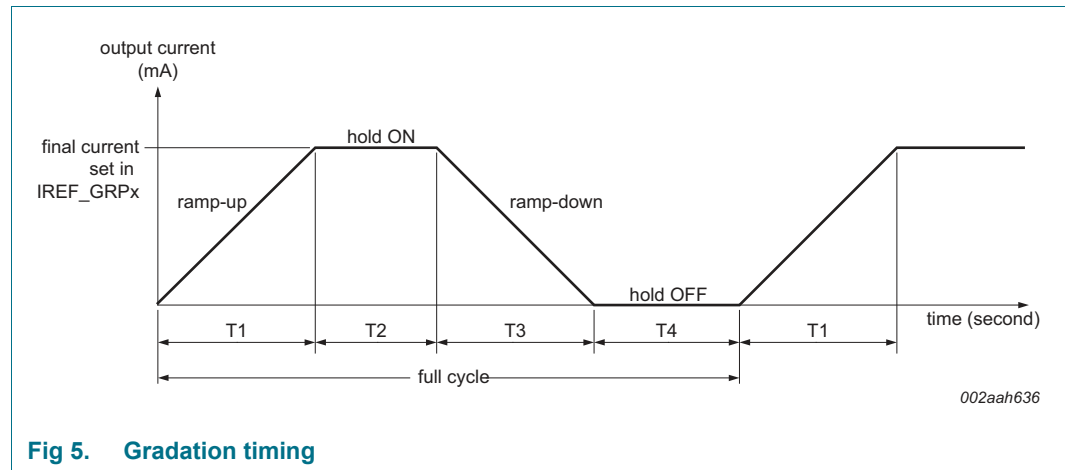

Fig 5. Gradation timing

- The 'final' and 'hold ON' current is defined in IREF_GRPx register value \times (225 μ A if $R_{ext} = 1$ k Ω , or 112.5 μ A if $R_{ext} = 2$ k Ω).
- Ramp rate value and enable/disable ramp operation is defined in RAMP_RATE_GRPx register.
- Total number of ramp steps (or level changes) is calculated as 'IREF_GRPx value' \div 'ramp rate value in RAMP_RATE_GRPx'. Rounds a number up to the next integer if the total number is not an integer.
- Time for each step is calculated as 'cycle time' \times 'multiple factor' bits in STEP_TIME_GRPx register. Minimum time for one step is 0.5 ms (0.5 ms \times 1) and maximum time is 512 ms (8 ms \times 64).
- The ramp-up or ramp-down time (T1 or T3) is calculated as '(total steps + 1) \times 'step time'.
- Hold ON or OFF time (T2 or T4) is defined in HOLD_CNTL_GRPx register in the range of 0/0.25/0.5/0.75/1/2/4/6 seconds.
- Gradation start or stop with single shot mode (one full cycle only) or continuous mode (repeat full cycle) is defined in the GRAD_CNTL register for all groups.
- Each channel can be assigned to one of these four groups in the GRAD_GRP_SELx register.
- Each channel can set either normal mode or gradation mode operation in the GRAD_MODE_SELx register.

To enable the gradation operation, the following steps are required:

1. Program all gradation control registers except the gradation start bit in GRAD_CNTL register.
2. Program either LDRx = 01 (LED fully ON mode) only, or LDRx = 10 or 11 (PWM control mode) with individual brightness control PWMx register for duty cycle.

3. Program output current value IREFx register to non-zero, which will enable LED output.
4. Set the gradation start bit in GRAD_CNTL register for enabling gradation operation.

7.2.8.1 RAMP_RATE_GRP0 to RAMP_RATE_GRP3, ramp rate control registers

Table 12. RAMP_RATE_GRP[0:3] - Ramp enable and rate control registers (address 28h, 2Ch, 30h, 34h) for each group bit description

Legend: * default value.

Address	Register	Bit	Access	Value	Description
28h	RAMP_RATE_GRP0	7	R/W	0*	Ramp-up disable
2Ch	RAMP_RATE_GRP1			1	Ramp-up enable
30h	RAMP_RATE_GRP2	6	R/W	0*	Ramp-down disable
34h	RAMP_RATE_GRP3			1	Ramp-down enable
		5:0	R/W	0x00*	Ramp rate value per step is defined from 1 (00h) to 64 (3Fh) ^{[1][2]}

[1] Total number of ramp steps is defined as 'IREF_GRP[7:0] ÷ 'ramp_rate[5:0]'. (Round up to next integer if it is not an integer number.)

[2] Per step current increment or decrement is calculated by the (ramp_rate × I_{ref}), where the I_{ref} reference current is 112.5 μA (R_{ext} = 2 kΩ) or 225 μA (R_{ext} = 1 kΩ).

7.2.8.2 STEP_TIME_GRP0 to STEP_TIME_GRP3, step time control registers

Table 13. STEP_TIME_GRP[0:3] - Step time control registers (address 29h, 2Dh, 31h, 35h) for each group bit description

Legend: * default value.

Address	Register	Bit	Access	Value	Description
29h	STEP_TIME_GRP0	7	read only	0*	reserved
2Dh	STEP_TIME_GRP1	6	R/W	0*	Cycle time is set to 0.5 ms
31h	STEP_TIME_GRP2			1	Cycle time is set to 8 ms
35h	STEP_TIME_GRP3	5:0	R/W	0x00*	Multiple factor per step, the multiple factor is defined from 1 (00h) to 64 (3Fh) ^[1]

[1] Step time = cycle time (0.5 ms or 8 ms) × multiple factor (1 ~ 64); minimum step time is 0.5 ms and maximum step time is 512 ms.

7.2.8.3 HOLD_CNTL_GRP0 to HOLD_CNTL_GRP3, hold ON and OFF control registers

Table 14. HOLD_CNTL_GRP[0:3] - Hold ON and OFF enable and time control registers (address 2Ah, 2Eh, 32h, 36h) for each group bit description

Legend: * default value.

Address	Register	Bit	Access	Value	Description
2Ah	HOLD_CNTL_GRP0	7	R/W	0*	Hold ON disable
2Eh	HOLD_CNTL_GRP1			1	Hold ON enable
32h	HOLD_CNTL_GRP2	6	R/W	0*	Hold OFF disable
36h	HOLD_CNTL_GRP3			1	Hold OFF enable
		5:3	R/W	000*	Hold ON time select: [1] 000: 0 s 001: 0.25 s 010: 0.5 s 011: 0.75 s 100: 1 s 101: 2 s 110: 4 s 111: 6 s
		2:0	R/W	000*	Hold OFF time select: [1] 000: 0 s 001: 0.25 s 010: 0.5 s 011: 0.75 s 100: 1 s 101: 2 s 110: 4 s 111: 6 s

[1] Hold ON or OFF minimum time is 0 s and maximum time is 6 s.

7.2.8.4 IREF_GRP0 to IREF_GRP3, output gain control

Table 15. IREF_GRP[0:3] - Final and hold ON output gain setting registers (address 2Bh, 2Fh, 33h, 37h) for each group bit description

Legend: * default value.

Address	Register	Bit	Access	Value	Description
2Bh	IREF_GRP0	7:0	R/W	00h*	Final ramp-up and hold ON output current gain setting [1]
2Fh	IREF_GRP1				
33h	IREF_GRP2				
37h	IREF_GRP3				

[1] Output current = $I_{ref} \times IREF_GRP[7:0]$, where I_{ref} is reference current. $I_{ref} = 112.5 \mu A$ if $R_{ext} = 2 k\Omega$, or $I_{ref} = 225 \mu A$ if $R_{ext} = 1 k\Omega$

7.2.8.5 GRAD_MODE_SEL0 to GRAD_MODE_SEL1, Gradation mode select registers

Table 16. GRAD_MODE_SEL[0:1] - Gradation mode select register for channel 15 to channel 0 (address 38h, 39h) bit description

Legend: * default value.

Address	Register	Bit	Access	Value	Description ^{[1][2]}
38h	GRAD_MODE_SEL0	7:0	R/W	00*	Normal operation mode for channel 7 to channel 0
				FFh	Gradation operation mode for channel 7 to channel 0
39h	GRAD_MODE_SEL1	7:0	R/W	00*	Normal operation mode for channel 15 to channel 8
				FFh	Gradation operation mode for channel 15 to channel 8

- [1] Each bit represents one channel that can set either 0 for normal mode (use IREFx to set individual LED output current), or 1 for gradation mode (use IREF_GRPx to set group LEDs output current.).
- [2] In gradation mode, it only affects the source of the IREF current level and does not affect the PWMx operation or LEDOUTx registers' function. It is possible to use the gradation feature, individual PWMx and group PWM simultaneously.

7.2.8.6 GRAD_GRP_SEL0 to GRAD_GRP_SEL3, Gradation group select registers

Table 17. GRAD_GRP_SEL[0:3] - Gradation group select register for channel 15 to channel 0 (address 3Ah, 3Bh, 3Ch, 3Dh) bit description

Legend: * default value.

Address	Register	Bit	Access	Value	Description ^[1]
3Ah	GRAD_GRP_SEL0	7:6	R/W	00*	Gradation group select for LED3 output
		5:4	R/W	00*	Gradation group select for LED2 output
		3:2	R/W	00*	Gradation group select for LED1 output
		1:0	R/W	00*	Gradation group select for LED0 output
3Bh	GRAD_GRP_SEL1	7:6	R/W	01*	Gradation group select for LED7 output
		5:4	R/W	01*	Gradation group select for LED6 output
		3:2	R/W	01*	Gradation group select for LED5 output
		1:0	R/W	01*	Gradation group select for LED4 output
3Ch	GRAD_GRP_SEL2	7:6	R/W	10*	Gradation group select for LED11 output
		5:4	R/W	10*	Gradation group select for LED10 output
		3:2	R/W	10*	Gradation group select for LED9 output
		1:0	R/W	10*	Gradation group select for LED8 output
3Dh	GRAD_GRP_SEL3	7:6	R/W	11*	Gradation group select for LED15 output
		5:4	R/W	11*	Gradation group select for LED14 output
		3:2	R/W	11*	Gradation group select for LED13 output
		1:0	R/W	11*	Gradation group select for LED12 output

- [1] LED[3:0] outputs default assigned to group 0; LED[7:4] outputs default assigned to group 1; LED[11:8] outputs default assigned to group 2; LED[15:12] outputs default assigned to group 3.

7.2.8.7 GRAD_CNTL, Gradation control register

Table 18. GRAD_CNTL - Gradation control register for group 3 to group 0 (address 3Eh) bit description

Legend: * default value.

Address	Register	Bit	Access	Value	Description
3Eh	GRAD_CNTL	7	R/W	0*	Gradation stop or done for group 3 ^[1]
				1	Gradation start for group 3 ^[2]
		6	R/W	0*	Single shot operation for group 3
				1	Continuous operation for group 3
		5	R/W	0*	Gradation stop or done for group 2 ^[1]
				1	Gradation start for group 2 ^[2]
		4	R/W	0*	Single shot operation for group 2
				1	Continuous operation for group 2
		3	R/W	0*	Gradation stop or done for group 1 ^[1]
				1	Gradation start for group 1 ^[2]
		2	R/W	0*	Single shot operation for group 1
				1	Continuous operation for group 1
		1	R/W	0*	Gradation stop or done for group 0 ^[1]
				1	Gradation start for group 0 ^[2]
		0	R/W	0*	Single shot operation for group 0
				1	Continuous operation for group 0

[1] When the gradation operation is forced to stop, the output current stops immediately and is frozen at the last output level.

[2] This bit will be self-cleared when single mode is completed, and writing 0 to this bit will force to stop the gradation operation when single mode is not completed or continuous mode is running.

7.2.8.8 Ramp control — equation and calculation example

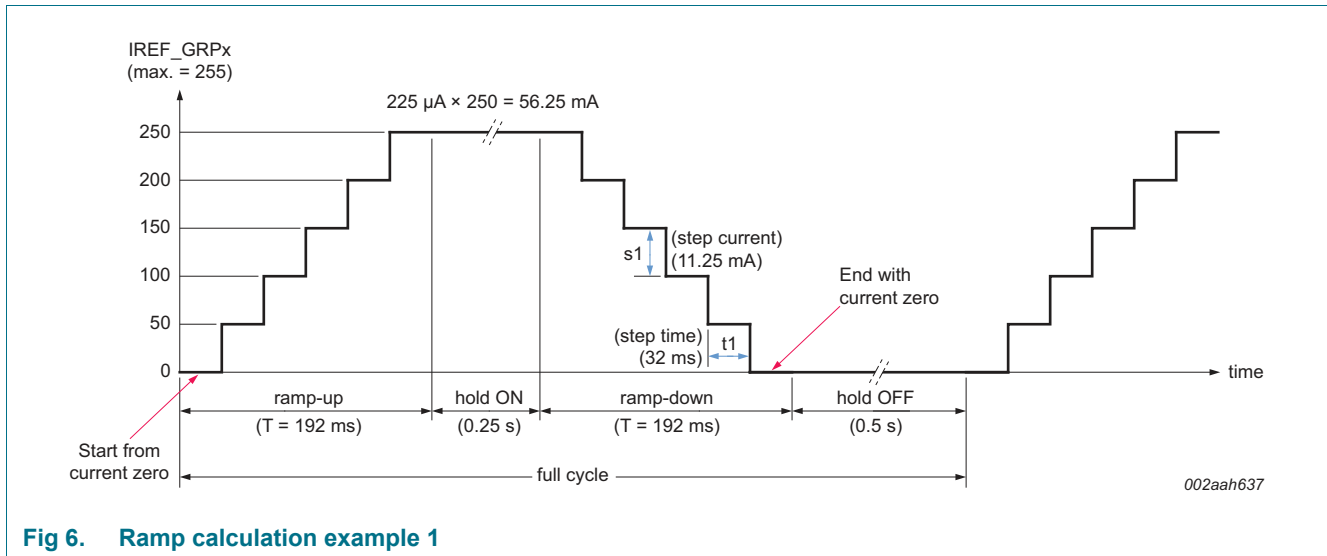

Fig 6. Ramp calculation example 1

- t_1 (step time) = cycle time \times multiple factor, where:
 - Cycle time = 0.5 ms (fast ramp) or 8 ms (slow ramp) in STEP_TIME_GRPx[6]
 - Multiple factor = 6-bit, from 1 (00h) to 64 (3Fh) counts in STEP_TIME_GRPx[5:0]
- s_1 (step current) = ramp_rate \times I_{ref} , where:
 - ramp_rate = 6-bit, from 1 (00h) to 64 (3Fh) counts in RAMP_RATE_GRPx[5:0]
 - I_{ref} = reference current either 112.5 μA if $R_{ext} = 2\text{ k}\Omega$, or 225 μA if $R_{ext} = 1\text{ k}\Omega$
- S (total steps) = (IREF_GRPx / ramp_rate), where:
 - IREF_GRPx = output current gain setting, 8-bit, up to 255 counts
 - ramp_rate = 6-bit, up to 64 counts in RAMP_RATE_GRPx[5:0]
 - If it is not an integer, then round up to next integer number.
- T (ramp time) = (S (total steps) + 1) \times t_1 (step time)
 - Ramp-up time starts from zero current and ends at the maximum current
 - Ramp-down time starts from the maximum current and ends at the zero current

Calculation example 1 (Figure 6):

- Assumption:
 - $I_{ref} = 225\text{ }\mu\text{A}$ if $R_{ext} = 1\text{ k}\Omega$
 - Output hold ON current = $225\text{ }\mu\text{A} \times 250 = 56.25\text{ mA}$ (IREF_GRPx[7:0] = FAh)
 - Cycle time = 0.5 ms (STEP_TIME_GRPx[6] = 0)
 - Multiple factor = 64 (STEP_TIME_GRPx[5:0] = 3Fh)
 - Ramp rate = 50 (RAMP_RATE_GRPx[5:0] = 31h)
 - Hold ON = 0.25 s (HOLD_CNTL_GRPx[5:3] = 001)
 - Hold OFF = 0.5 s (HOLD_CNTL_GRPx[2:0] = 010)
- t_1 (step time) = cycle time (0.5 ms) \times multiple (64) = 32 ms
- Step current = ramp_rate \times $I_{ref} = 50 \times 225\text{ }\mu\text{A} = 11.25\text{ mA}$

- S (total steps) = $(I_{REF_GRP_x} \div \text{ramp_rate}) = (250 \div 50) = 5$ steps
- T (ramp time) = $(S + 1) \times t_1 = 6 \times 32 \text{ ms} = 192 \text{ ms}$

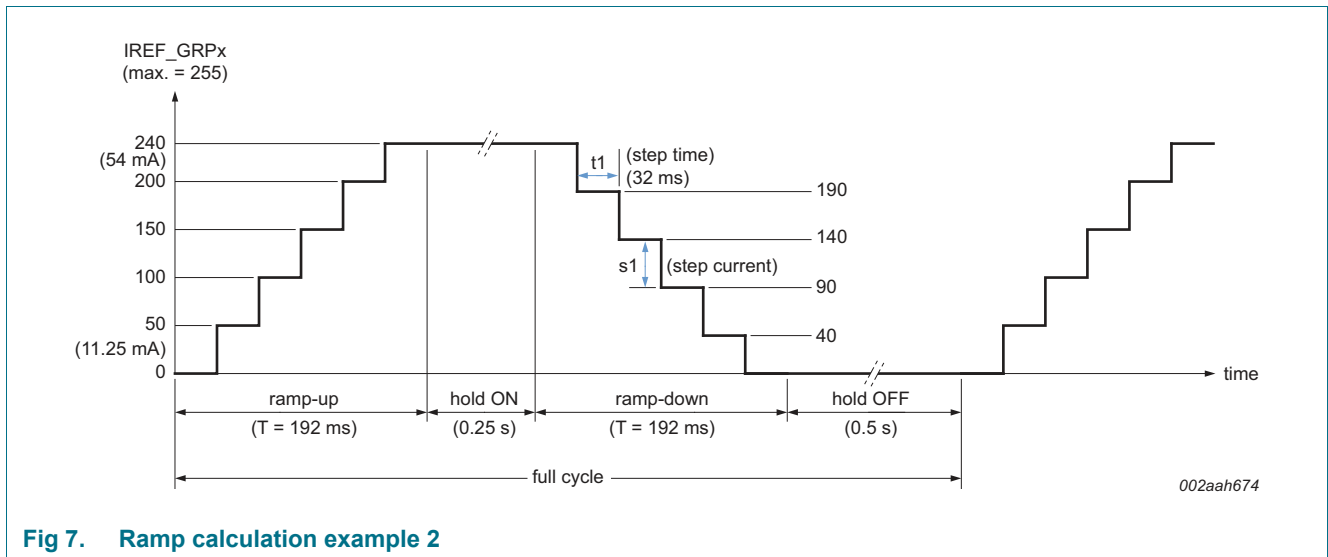

Fig 7. Ramp calculation example 2

Calculation example 2:

- Assumption:
 - $I_{ref} = 225 \mu\text{A}$ if $R_{ext} = 1 \text{ k}\Omega$
 - Output hold ON current = $225 \mu\text{A} \times 240 = 54 \text{ mA}$ ($I_{REF_GRP_x}[7:0] = F0h$)
 - Cycle time = 0.5 ms ($STEP_TIME_GRP_x[6] = 0$)
 - Multiple factor = 64 ($STEP_TIME_GRP_x[5:0] = 3Fh$)
 - Ramp rate = 50 ($RAMP_RATE_GRP_x[5:0] = 31h$)
 - Hold ON = 0.25 s ($HOLD_CNTL_GRP_x[5:3] = 001$)
 - Hold OFF = 0.5 s ($HOLD_CNTL_GRP_x[2:0] = 010$)
- t_1 (step time) = cycle time (0.5 ms) \times multiple (64) = 32 ms
- Step current = ramp_rate \times $I_{ref} = 50 \times 225 \mu\text{A} = 11.25 \text{ mA}$ (except the last one)
- S (total steps) = $I_{REF_GRP_x} \div \text{ramp_rate} = 240 \div 50 = 4.8$ steps (round up to next integer) = 5 steps
- T (ramp time) = $(S + 1) \times t_1 = 6 \times 32 \text{ ms} = 192 \text{ ms}$

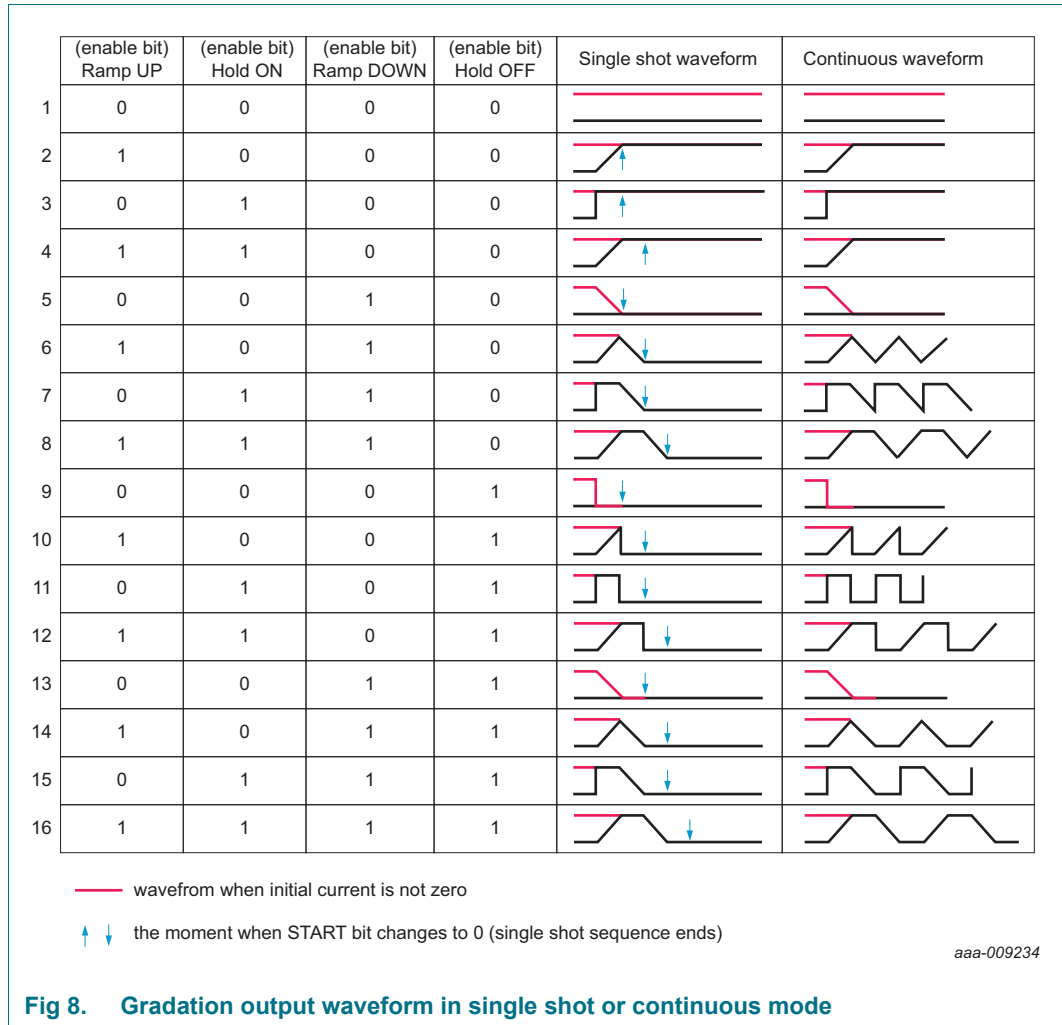

Fig 8. Gradation output waveform in single shot or continuous mode

7.2.9 OFFSET — LEDn output delay offset register

Table 19. OFFSET - LEDn output delay offset register (address 3Fh) bit description

Legend: * default value.

Address	Register	Bit	Access	Value	Description
3Fh	OFFSET	7:4	read only	0000*	not used
		3:0	R/W	1000*	LEDn output delay offset factor

The PCA9745B can be programmed to have turn-on delay between LED outputs. This helps to reduce peak current for the V_{DD} supply and reduces EMI.

The order in which the LED outputs are enabled will always be the same (channel 0 will enable first and channel 15 will enable last).

OFFSET control register bits [3:0] determine the delay used between the turn-on times as follows:

- 0000 = no delay between outputs (all on, all off at the same time)
- 0001 = delay of 1 clock cycle (125 ns) between successive outputs
- 0010 = delay of 2 clock cycles (250 ns) between successive outputs
- 0011 = delay of 3 clock cycles (375 ns) between successive outputs
- :
- 1111 = delay of 15 clock cycles (1.875 μ s) between successive outputs

Example: If the value in the OFFSET register is 1000 the corresponding delay = $8 \times 125 \text{ ns} = 1 \mu\text{s}$ delay between successive outputs.

- channel 0 turns on at time 0 μ s
- channel 1 turns on at time 1 μ s
- channel 2 turns on at time 2 μ s
- channel 3 turns on at time 3 μ s
- channel 4 turns on at time 4 μ s
- channel 5 turns on at time 5 μ s
- channel 6 turns on at time 6 μ s
- channel 7 turns on at time 7 μ s
- channel 8 turns on at time 8 μ s
- channel 9 turns on at time 9 μ s
- channel 10 turns on at time 10 μ s
- channel 11 turns on at time 11 μ s
- channel 12 turns on at time 12 μ s
- channel 13 turns on at time 13 μ s
- channel 14 turns on at time 14 μ s
- channel 15 turns on at time 15 μ s

7.2.10 PWMALL — brightness control for all LEDn outputs

When programmed, the value in this register will be used for PWM duty cycle for all the LEDn outputs and will be reflected in PWM0 through PWM15 registers.

Table 20. PWMALL - brightness control for all LEDn outputs register (address 40h) bit description

Legend: * default value.

Address	Register	Bit	Access	Value	Description
40h	PWMALL	7:0	write only	0000 0000*	duty cycle for all LEDn outputs

Remark: Write to any of the PWM0 to PWM15 registers will overwrite the value in corresponding PWMn register programmed by PWMALL.

7.2.11 IREFALL register: output current value for all LED outputs

The output current setting for all outputs is held in this register. When this register is written to or updated, all LED outputs will be set to a current corresponding to this register value.

Writes to IREF0 to IREF15 will overwrite the output current settings.

Table 21. IREFALL - Output gain control for all LED outputs (address 41h) bit description

Legend: * default value.

Address	Register	Bit	Access	Value	Description
41h	IREFALL	7:0	write only	00h*	Current gain setting for all LED outputs.

7.2.12 LED driver constant current outputs

In LED display applications, PCA9745B provides nearly no current variations from channel to channel and from device to device. The maximum current skew between channels is less than ±4 % and less than ±6 % between devices.

7.2.12.1 Adjusting output current

The PCA9745B scales up the reference current (I_{ref}) set by the external resistor (R_{ext}) to sink the output current (I_O) at each output port. The maximum output current for the outputs can be set using R_{ext} . In addition, the constant value for current drive at each of the outputs is independently programmable using command registers IREF0 to IREF15. Alternatively, programming the IREFALL register allows all outputs to be set at one current value determined by the value in IREFALL register.

[Equation 4](#) and [Equation 5](#) can be used to calculate the minimum and maximum constant current values that can be programmed for the outputs for a chosen R_{ext} .

$$I_{O_LED_MIN} = \frac{900 \text{ mV}}{R_{ext}} \times \frac{I}{4} \text{ (minimum constant current)} \tag{4}$$

$$I_{O_LED_MAX} = (255 \times I_{O_LED_MIN}) = \left(\frac{900 \text{ mV}}{R_{ext}} \times \frac{255}{4} \right) \tag{5}$$

For a given IREFx setting, $I_{O_LED} = IREFx \times \frac{900 \text{ mV}}{R_{ext}} \times \frac{I}{4}$.

Remark: The open/short circuit source voltage is influenced by the external resistor R_{ext} and may falsely trigger the open condition if R_{ext} is bigger than 3.6 k Ω . Use 3 k Ω or smaller R_{ext} to guarantee no false open triggers; if smaller analog currents are required with R_{ext} larger than 3 k Ω then don't use the open/short detection.

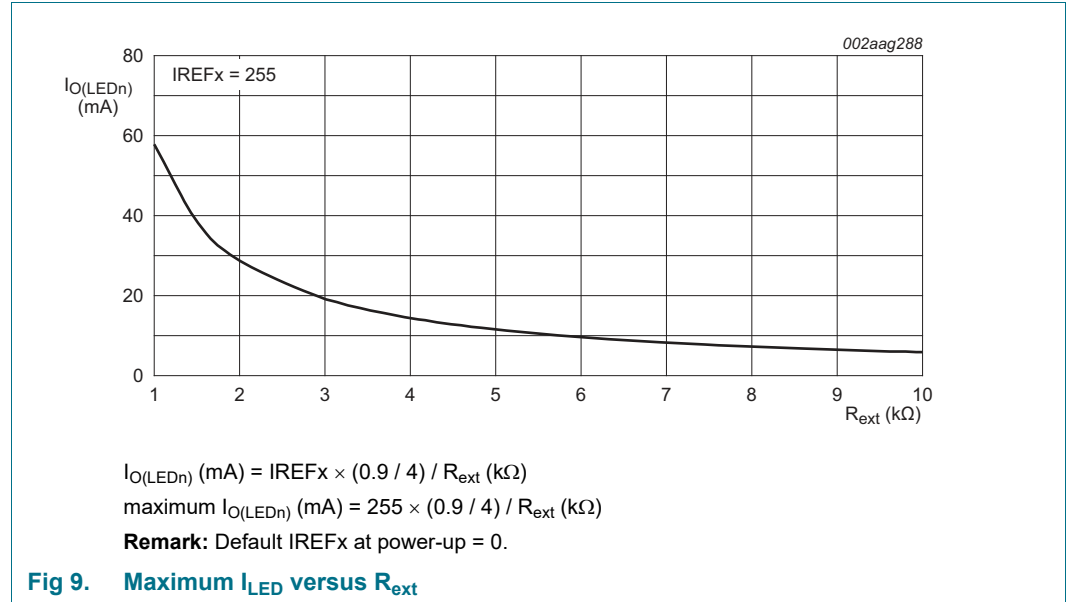

Example 1: If $R_{ext} = 1 \text{ k}\Omega$, $I_{O_LED_MIN} = 225 \mu\text{A}$, $I_{O_LED_MAX} = 57.375 \text{ mA}$ (as shown in [Figure 10](#)).

So each channel can be programmed with its individual IREFx in 256 steps and in 225 μA increments to a maximum output current of 57.375 mA independently.

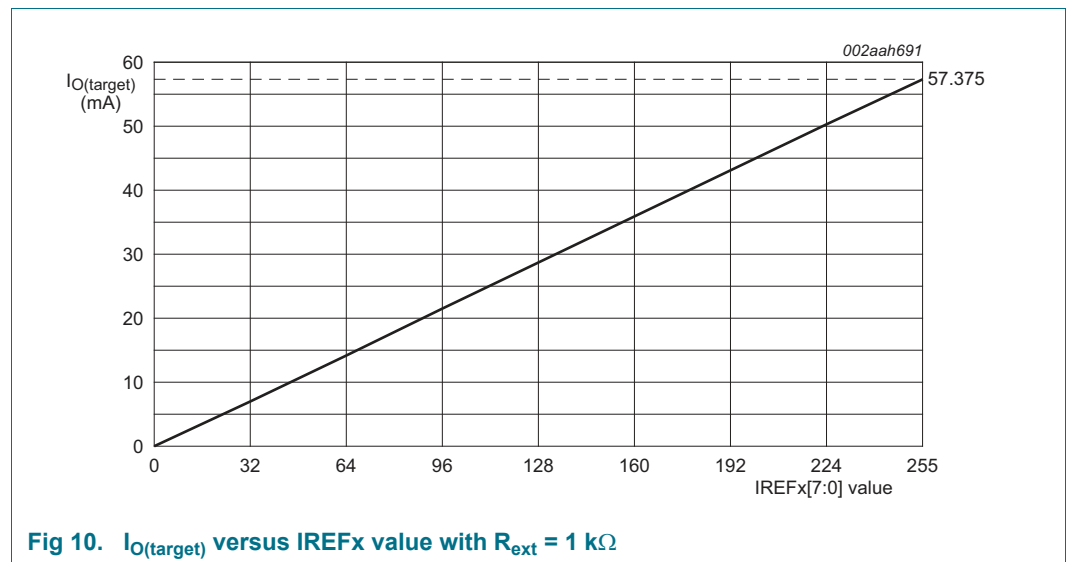

Example 2: If $R_{ext} = 2\text{ k}\Omega$, $I_{O_LED_MIN} = 112.5\ \mu\text{A}$, $I_{O_LED_MAX} = 28.687\text{ mA}$ (as shown in [Figure 11](#)).

So each channel can be programmed with its individual IREFx in 256 steps and in 112.5 μA increments to a maximum output channel of 28.687 mA independently.

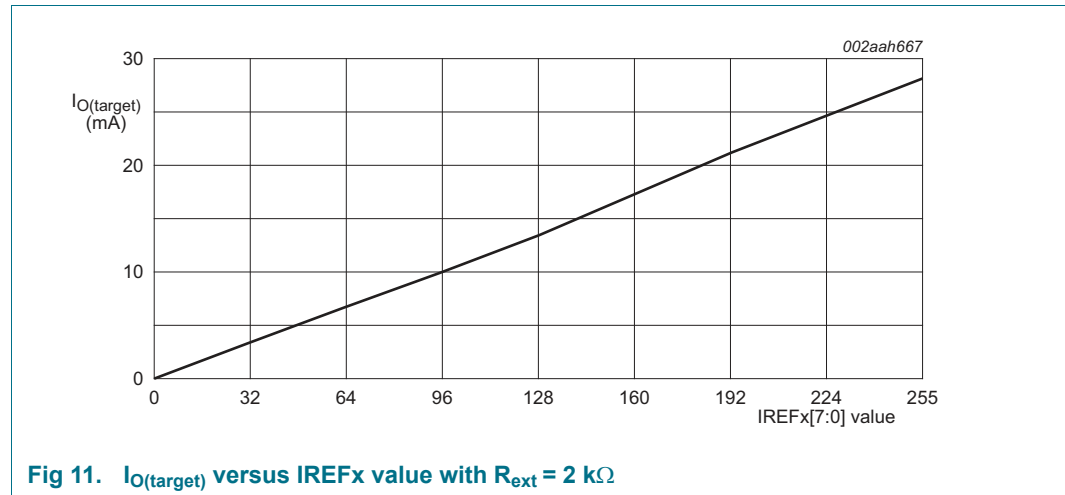

Fig 11. $I_{O(target)}$ versus IREFx value with $R_{ext} = 2\text{ k}\Omega$

7.2.13 LED error detection

The PCA9745B is capable of detecting an LED open or a short condition at its open-drain LED outputs. Users will recognize these faults by reading the status of a pair of error bits (ERRx) in error flag registers (EFLAGn) for each channel. Both LDRx value in LEDOUTx registers and IREFx value must be set to '00' for those unused LED output channels. If the output is selected to be fully on, individual dim, or individual and group dim, that channel will be tested.

The user can poll the ERROR status bit (bit 6 in MODE2 register) to check if there is a fault condition in any of the 16 channels. The EFLAGn registers can then be read to determine which channels are at fault and the type of fault in those channels. The error status reported by the EFLAGn register is real time information that will get self cleared once the error is fixed and write '1' to CLRERR bit (bit 4 in MODE2 register).

Remark: When LED outputs programmed with LDRx = 10 or 11 in LEDOUT[3:0] registers, checks for open and short-circuit will not occur if the PWM value in PWM0 to PWM15 registers is less than 8 or 255 (100 % duty cycle).

Remark: The open/short circuit source voltage is influenced by the external resistor R_{ext} and may falsely trigger the open condition if R_{ext} is bigger than 3.6 k Ω . Use 3 k Ω or smaller R_{ext} to guarantee no false open triggers; if smaller analog currents are required with R_{ext} larger than 3 k Ω then don't use the open/short detection.

Table 22. EFLAG0 to EFLAG3 - Error flag registers (address 42h to 45h) bit description

Legend: * default value.

Address	Register	Bit	Symbol	Access	Value	Description
42h	EFLAG0	7:6	ERR3	R only	00*	Error status for LED3 output
		5:4	ERR2	R only	00*	Error status for LED2 output
		3:2	ERR1	R only	00*	Error status for LED1 output
		1:0	ERR0	R only	00*	Error status for LED0 output
43h	EFLAG1	7:6	ERR7	R only	00*	Error status for LED7 output
		5:4	ERR6	R only	00*	Error status for LED6 output
		3:2	ERR5	R only	00*	Error status for LED5 output
		1:0	ERR4	R only	00*	Error status for LED4 output
44h	EFLAG2	7:6	ERR11	R only	00*	Error status for LED11 output
		5:4	ERR10	R only	00*	Error status for LED10 output
		3:2	ERR9	R only	00*	Error status for LED9 output
		1:0	ERR8	R only	00*	Error status for LED8 output
45h	EFLAG3	7:6	ERR15	R only	00*	Error status for LED15 output
		5:4	ERR14	R only	00*	Error status for LED14 output
		3:2	ERR13	R only	00*	Error status for LED13 output
		1:0	ERR12	R only	00*	Error status for LED12 output

Table 23. ERRx bit description

LED error detection status	ERRx		Description
	Bit 1	Bit 0	
No error	0	0	In normal operation and no error
Short-circuit	0	1	Detected LED short-circuit condition
Open-circuit	1	0	Detected LED open-circuit condition
DNE (Do Not Exist)	1	1	This condition does not exist

7.2.13.1 Open-circuit detection principle

The PCA9745B LED open-circuit detection compares the effective current level I_O with the open load detection threshold current $I_{th(det)}$. If I_O is below the threshold $I_{th(det)}$, the PCA9745B detects an open load condition. This error status can be read out as an error flag through the EFLAGn registers. For open-circuit error detection of an output channel, that channel must be ON.

Table 24. Open-circuit detection

State of output port	Condition of output current	Error status code	Description
OFF	$I_O = 0 \text{ mA}$	0	detection not possible
ON	$I_O < I_{th(det)}$ ^[1]	1	open-circuit
	$I_O \geq I_{th(det)}$ ^[1]	this channel open error status bit is 0	normal

[1] $I_{th(det)} = 0.5 \times I_{O(target)}$ (typical). This threshold may be different for each I/O and only depends on IREFx and R_{ext}.

7.2.13.2 Short-circuit detection principle

The LED short-circuit detection compares the effective output voltage level (V_O) with the shorted-load detection threshold voltages $V_{th(trig)}$. If V_O is above the $V_{th(trig)}$ threshold, the PCA9745B detects a shorted-load condition. If V_O is below the $V_{th(trig)}$ threshold, no error is detected and error bit is set to '0'. This error status can be read out as an error flag through the EFLAGn registers. For short-circuit error detection of an output channel, that channel must be ON.

Table 25. Short-circuit detection

State of output port	Condition of output voltage	Error status code	Description
OFF	-	0	detection not possible
ON	$V_O \geq V_{th(trig)}$ ^[1]	1	short-circuit
	$V_O < V_{th(trig)}$ ^[1]	this channel short error status bit is 0	normal

[1] $V_{th} \approx 2.85 \text{ V}$.

Remark: The error status distinguishes between an LED short condition and an LED open condition. Upon detecting an LED short or open, the corresponding LED outputs should be turned OFF to prevent heat dissipation for a short in the chip. Although an open event will not be harmful, the outputs should be turned OFF for both occasions to repair the LED string.

7.2.14 Overtemperature protection

If the PCA9745B chip temperature exceeds its limit ($T_{th(otp)}$ (rising) maximum, see [Table 28](#)), all output channels will be disabled until the temperature drops below its limit minus a small hysteresis ($T_{th(otp)}$ (hysteresis) maximum, see [Table 28](#)). When an overtemperature situation is encountered, the OVERTEMP flag (bit 7) is set in the MODE2 register. Once the die temperature reduces below the $T_{th(otp)}$ rising – $T_{th(otp)}$ hysteresis, the chip will return to the same condition it was prior to the overtemperature event and the OVERTEMP flag will be cleared.

7.3 Active LOW output enable input

The active LOW output enable (\overline{OE}) pin on PCA9745B allows to enable or disable all the LED outputs at the same time.

- When a LOW level is applied to \overline{OE} pin, all the LED outputs are enabled.
- When a HIGH level is applied to \overline{OE} pin, all the LED outputs are high-impedance.

The \overline{OE} pin can be used as a synchronization signal to switch on/off several PCA9745B devices at the same time when LED drive output state is set fully ON ($LDRx = 01$ in LEDOUTx register) in these devices. This requires an external clock reference that provides blinking period and the duty cycle.

The \overline{OE} pin can also be used as an external dimming control signal. The frequency of the external clock must be high enough not to be seen by the human eye, and the duty cycle value determines the brightness of the LEDs.

Remark: Do not use \overline{OE} as an external blinking control signal when internal global blinking is selected ($DMBLNK = 1$, MODE2 register) since it will result in an undefined blinking pattern. Do not use \overline{OE} as an external dimming control signal when internal global dimming is selected ($DMBLNK = 0$, MODE2 register) since it will result in an undefined dimming pattern.

7.4 Power-on reset

When power is applied to V_{DD} , an internal power-on reset holds the PCA9745B in a reset condition until V_{DD} has reached V_{POR} . At this point, the reset condition is released and the PCA9745B registers and serial bus state machine are initialized to their default states (all zeroes) causing all the channels to be deselected. Thereafter, V_{DD} must be pulled lower than 1 V and stay LOW for longer than 20 μ s. The device will reset itself, and allow 2 ms for the device to fully wake up.

7.5 Hardware reset recovery

When a reset of PCA9745B is activated using an active LOW input on the \overline{RESET} pin, a reset pulse width of 2.5 μ s minimum is required. The maximum wait time after \overline{RESET} pin is released is 1.5 ms.

7.6 Individual brightness control with group dimming/blinking

A 31.25 kHz fixed frequency signal with programmable duty cycle (8 bits, 256 steps) is used to control individually the brightness for each LED.

On top of this signal, one of the following signals can be superimposed (this signal can be applied to the 16 LED outputs LED0 to LED15).

- A lower 122 Hz fixed frequency signal with programmable duty cycle (8 bits, 256 steps) is used to provide a global brightness control.
- A programmable frequency signal from 15 Hz to every 16.8 seconds (8 bits, 256 steps) with programmable duty cycle (8 bits, 256 steps) is used to provide a global blinking control.

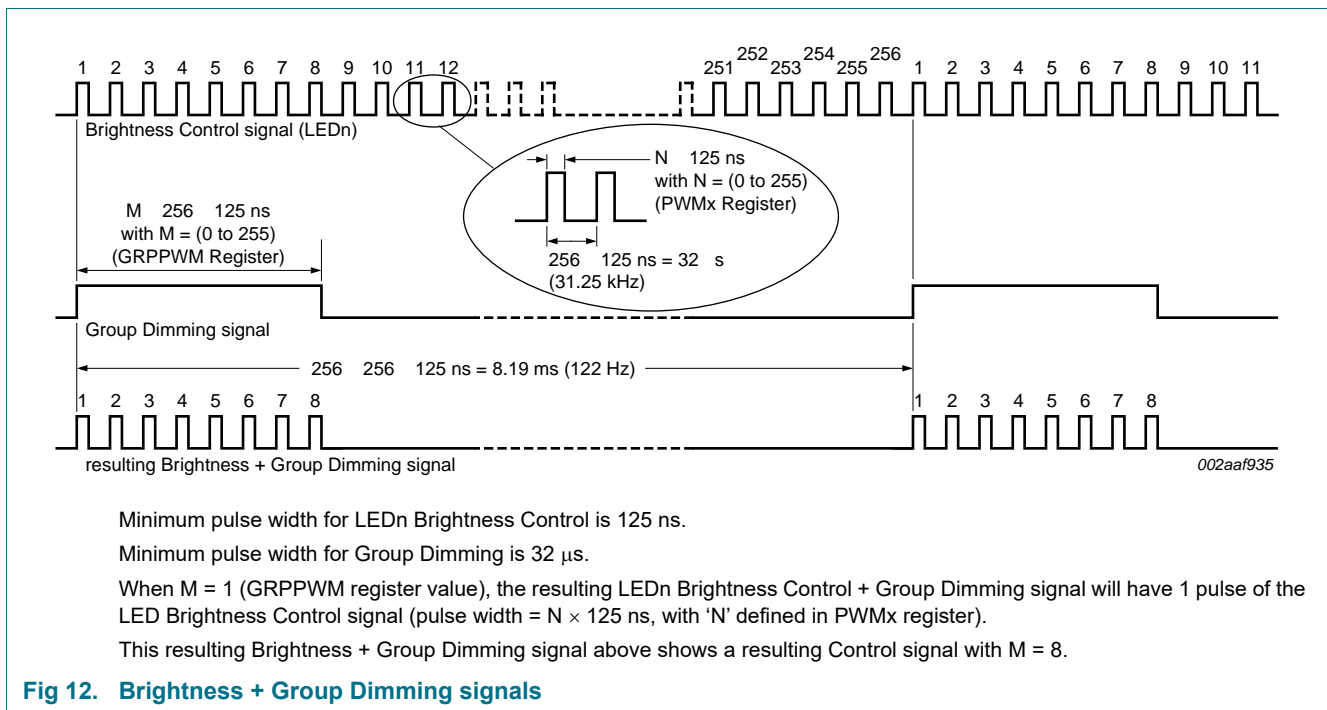

Fig 12. Brightness + Group Dimming signals

8. Characteristics of the 4-wire SPI serial-bus interface

The PCA9745B communicates through a daisy-chain SPI-compatible 4-wire serial interface. The interface has three inputs and one output: serial clock (SCLK), active LOW chip select (\overline{CS}), serial data in (SDI) and serial data output (SDO). \overline{CS} must be LOW to clock data into the device, and SDI must be stable when sampled on the rising edge of SCLK. The PCA9745B will ignore all activity on SCLK and SDI except when \overline{CS} is LOW.

8.1 SPI-compatible 4-wire serial interface signals

\overline{CS} — The active LOW chip select line is used to activate and access the SPI slaves. As long as \overline{CS} is HIGH, all slaves will not accept the clock signal or data, and the output SDO is in high-impedance state. Whenever this pin is in a logic LOW state, data can be transferred between the master and all slaves.

SCLK — Serial clock is provided by SPI master and determines the speed of the data transfer. All receiving and sending data are done synchronously (clocks the internal SPI shift register and the output driver) to this clock.

SDI — Serial Data In is read on the rising edge of SCLK into the internal 16-bit shift registers. On the rising edge of \overline{CS} , the input data is latched into the internal registers of the device. The device ignores all activity on SDI when \overline{CS} is de-asserted.

SDO — Serial Data Out is the pin on which the internal 16-bit shift registers data is shifted out serially. SDO is in a high-impedance state until the \overline{CS} pin goes to a logic LOW state. New data will appear at the SDO pin following the falling edge of SCLK.

All slave devices can be daisy-chained by connecting the SDO of one device to the SDI of the next device, and driving SCLK and \overline{CS} lines in parallel. [Figure 13](#) depicts how the slaves are connected to the master. All slave devices are accessed at the same time with \overline{CS} . An access requires $(16 \times n)$ clock cycles, where 'n' is the number of slave devices. As long as \overline{CS} is LOW, the SPI registers are working as simple shift registers and shifting through the SDI data without interpreting the different control and data bits. When \overline{CS} goes back to HIGH, the bits in the SPI registers are interpreted and the SPI logic is activated.

Only the first slave in the chain receives the control and data bits directly from the SPI Master. Every other slave in the network receives its SDI data from the SDO output of the preceding slave in the chain, and the SDO of the last slave is then connected to the data input (MISO) of SPI Master. Each slave has 16-bit shift registers shifted in from SDI and shifted out to SDO, along with the SCLK clock. The whole chain acts as a $(n \times 16\text{-bit})$, where 'n' is number of slaves) big shift register.

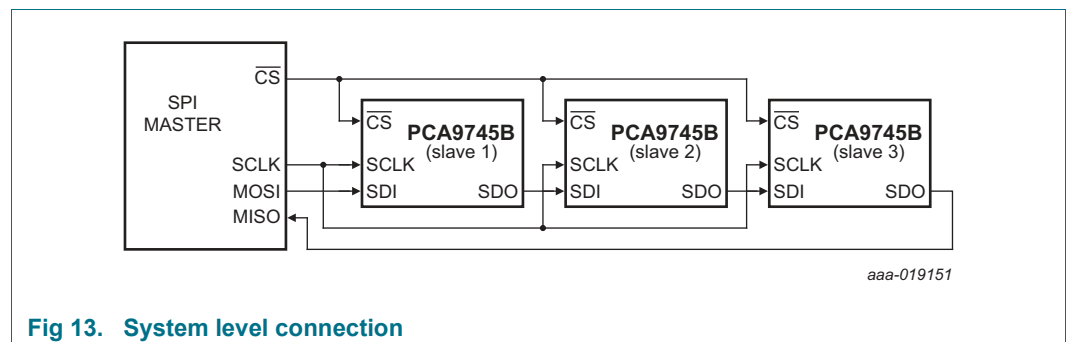

Fig 13. System level connection

8.2 Data format

As shown in [Figure 14](#), the data transfers are 16-bit × n bits wide (where ‘n’ is the number of slaves) with MSB transferred first. The first 7 bits, D[15:9], form the address of the register to be accessed, the eighth bit (D8) indicates the types of access, either read (= 1) or write (= 0), and the last 8 bits, D[7:0], consist of data. Register read and write sequences (described in the following sections) always begin from the bus idle condition. The bus idle condition refers to CS being HIGH and SCLK being in a LOW state.

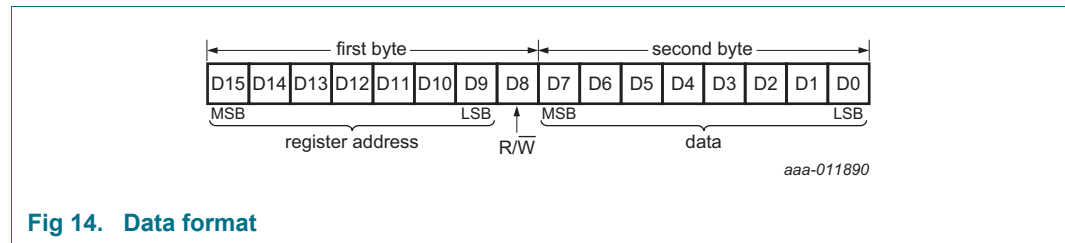

Fig 14. Data format

8.3 Write access sequence

The registers are written using the following write sequence (from a bus idle condition) when the system has three slaves daisy-chained together:

1. All the slave devices in chain will be involved in a write or read operation. Every slave device in the chain is a portion of one big shift register.
2. Drive \overline{CS} LOW. This enables the internal 16-bit shift register.
3. Shift $16 \times n$ bits of data (where ‘n’ is the number of slaves) into the first slave device in a MSB-first fashion. Data is shifted on the rising edge of SCLK and must be stable during the rising edge of SCLK.
4. The 8th bit of the data for every 16 bits (each device) must be a ‘0’, indicating it is a write transfer.
5. After the last bit of data is transferred, drive SCLK LOW and de-assert CS (drive it HIGH).
6. When \overline{CS} goes from LOW to HIGH, the data in the shift register is latched into the device registers.

If fewer than 16 bits of data are transferred before de-asserting \overline{CS} , then the data is ignored and the register will not be updated. The write transfer format is shown in [Figure 15](#).

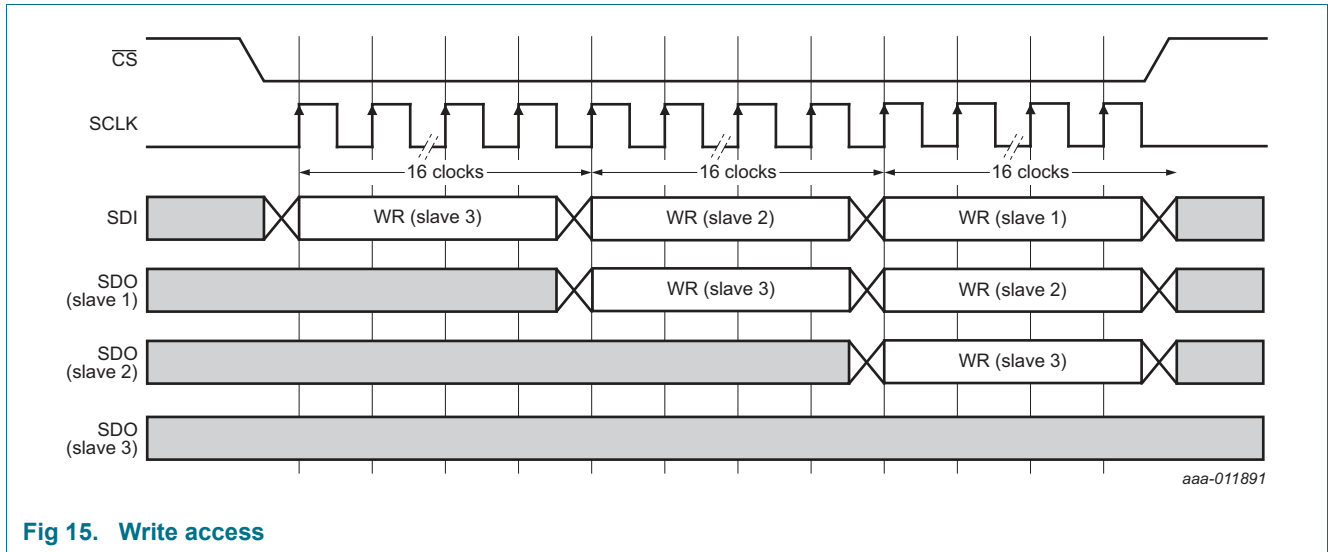

Fig 15. Write access

8.4 Read access sequence

The registers are read using the following read sequence (from a bus idle condition) when the system has three slaves daisy-chained as shown in [Figure 16](#).

1. The master sends the first three 2-byte read instructions with 48 clocks, where the first byte is a 7-bit register address, an eighth bit set to one, followed by dummy data byte (all ones).
2. The Read instruction is decoded when \overline{CS} is de-asserted (from LOW to HIGH).
3. The read data is shifted out on SDO when \overline{CS} is asserted again (from HIGH to LOW).
4. The master sends the second three 2-byte 'No Operation' (NOP) operations (all ones) with 48 clocks and reads the requested data on MISO in sequence where the first byte is dummy data (don't care), followed by the read data byte.
5. A read cycle consists of asserting and de-asserting of \overline{CS} twice.

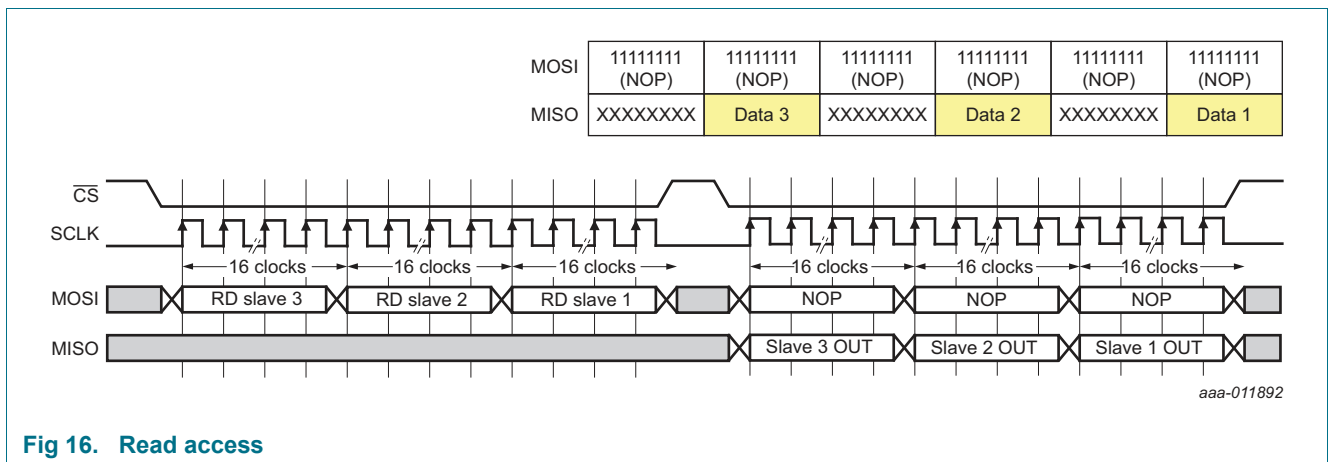

Fig 16. Read access

8.5 Overlapped read and write access sequence

The registers are read and write overlapped using the following sequence (from a bus idle condition) when the system has three slaves daisy-chained as shown in [Figure 17](#).

1. The second phase of the read cycle can be used to send in write data or the next read instruction. This increases the bus utility and hence efficiency.
2. The master sends the first three 2-byte read instructions with 48 clocks, where the first byte is a 7-bit register address, the eighth bit is set to one, followed by dummy data byte (all ones).
3. The read instruction is decoded when \overline{CS} is de-asserted (from LOW to HIGH).
4. Start to shift read data out on SDO when \overline{CS} is asserted again (from HIGH to LOW) and start to send in the next read or write instruction on the SDI line.

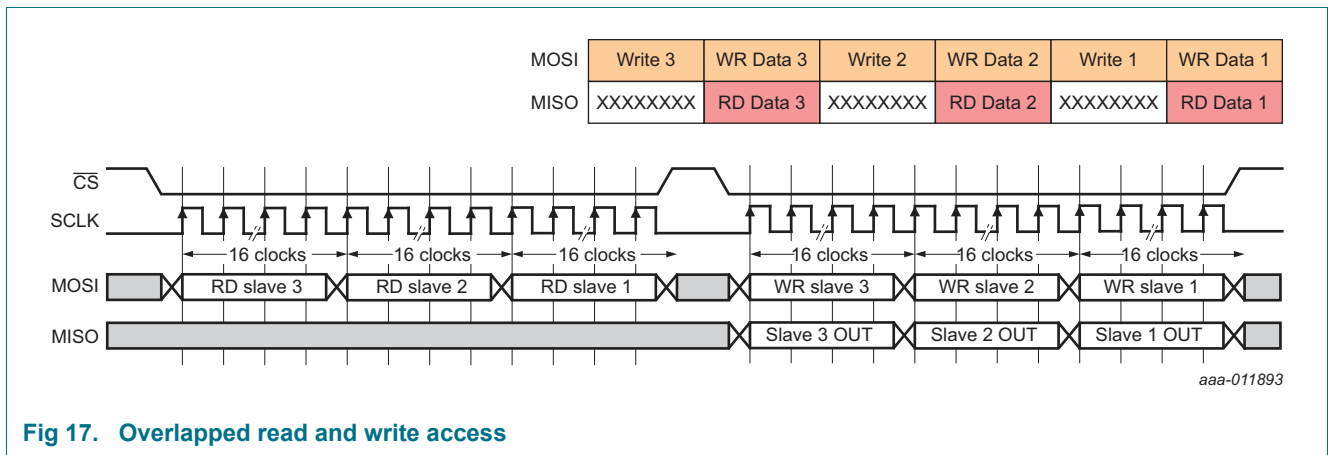
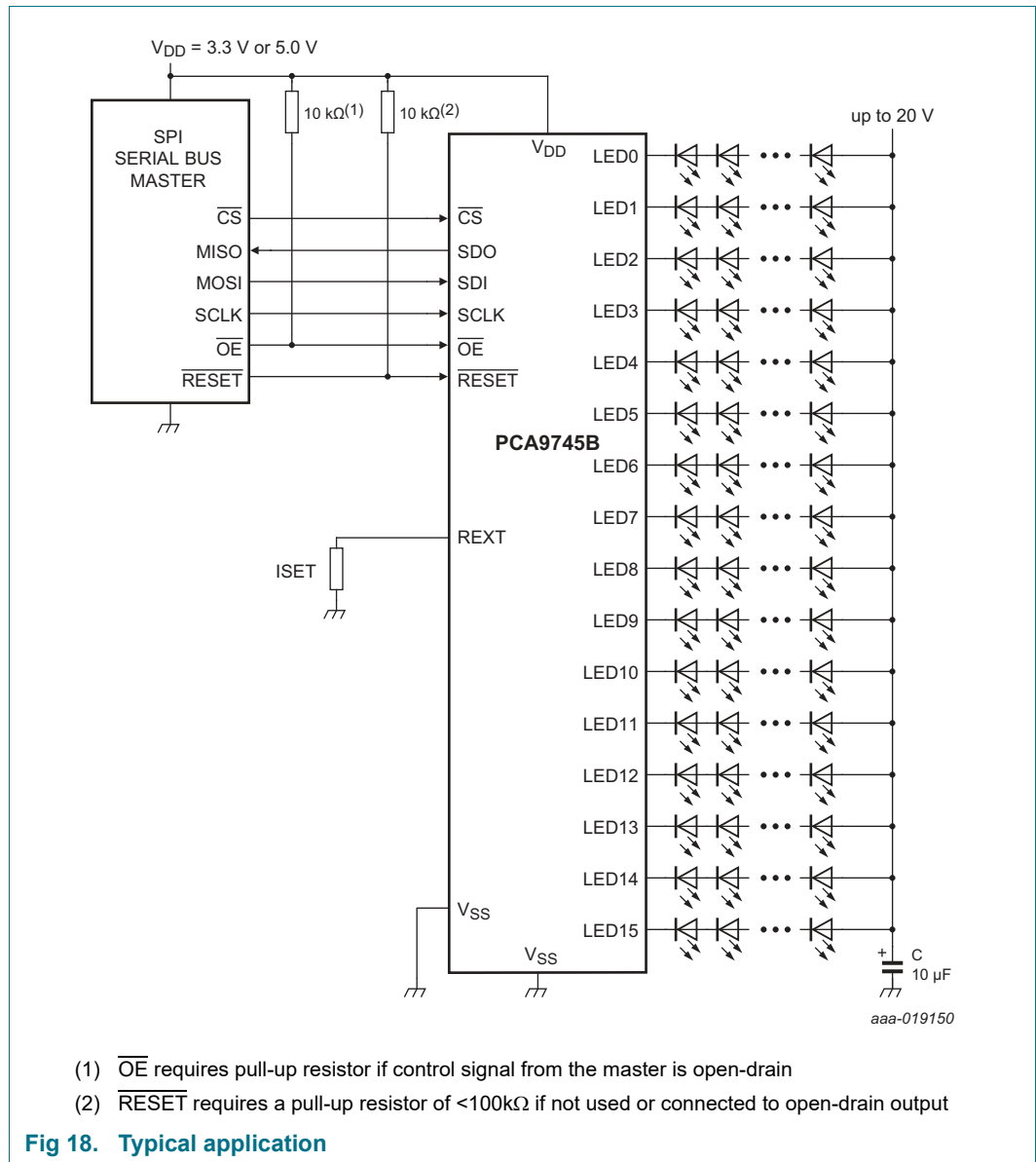

Fig 17. Overlapped read and write access

9. Application design-in information



9.1 Thermal considerations

Since the PCA9745B device integrates 16 linear current sources, thermal considerations should be taken into account to prevent overheating, which can cause the device to go into thermal shutdown.

Perhaps the major contributor for device's overheating is the LED forward voltage mismatch. This is because it can cause significant voltage differences between the LED strings of the same type (for example, 2 V to 3 V), which ultimately translates into higher power dissipation in the device. The voltage drop across the LED channels of the device is given by the difference between the supply voltage and the LED forward voltage of each

LED string. Reducing this to a minimum (for example, 0.8 V) helps to keep the power dissipation down. Therefore LEDs binning is recommended to minimize LED voltage forward variation and reduce power dissipation in the device.

In order to ensure that the device will not go into thermal shutdown when operating under certain application conditions, its junction temperature (T_j) should be calculated to ensure that is below the overtemperature threshold limit (130 °C). The T_j of the device depends on the ambient temperature (T_{amb}), device's total power dissipation (P_{tot}), and thermal resistance.

The device junction temperature can be calculated by using the following equation:

$$T_j = T_{amb} + R_{th(j-a)} \times P_{tot} \quad (6)$$

where:

T_j = junction temperature

T_{amb} = ambient temperature

$R_{th(j-a)}$ = junction to ambient thermal resistance

P_{tot} = (device) total power dissipation

An example of this calculation is show below:

Conditions:

$T_{amb} = 50 \text{ °C}$

$R_{th(j-a)} = 39 \text{ °C/W}$ (per JEDEC 51 standard for multilayer PCB)

$I_{LED} = 30 \text{ mA / channel}$

$I_{DD(max)} = 20 \text{ mA}$

$V_{DD} = 5 \text{ V}$

LEDs per channel = 5 LEDs / channel

LED $V_{F(typ)} = 3 \text{ V}$ per LED (15 V total for 5 LEDs in series)

LED V_F mismatch = 0.2 V per LED (1 V total for 5 LEDs in series)

$V_{reg(drv)} = 0.8 \text{ V}$ (This will be present only in the LED string with the highest LED forward voltage.)

$V_{sup} = LED V_{F(typ)} + LED V_F \text{ mismatch} + V_{reg(drv)} = 15 \text{ V} + 1 \text{ V} + 0.8 \text{ V} = 16.8 \text{ V}$

P_{tot} calculation:

$P_{tot} = IC_power + LED \text{ drivers_power};$

$IC_power = (I_{DD} \times V_{DD})$

$IC_power = (0.02 \text{ A} \times 5 \text{ V}) = 0.1 \text{ W}$

$LED \text{ drivers_power} = [(16 - 1) \times (I_{LED}) \times (LED V_F \text{ mismatch} + V_{reg(drv)})] + (I_{LED} \times V_{reg(drv)})$

$LED \text{ drivers_power} = [15 \times 0.03 \text{ A} \times (1 \text{ V} + 0.8 \text{ V})] + (0.03 \text{ A} \times 0.8 \text{ V}) = 0.834 \text{ W}$

$P_{tot} = 0.1 \text{ W} + 0.834 \text{ W} = 0.934 \text{ W}$

T_j calculation:

$$T_j = T_{amb} + R_{th(j-a)} \times P_{tot}$$

$$T_j = 50 \text{ °C} + (39 \text{ °C/W} \times 0.934 \text{ W}) = 86.426 \text{ °C}$$

This confirms that the junction temperature is below the minimum overtemperature threshold of 130 °C, which ensures the device will not go into thermal shutdown under these conditions.

It is important to mention that the value of the thermal resistance junction-to-ambient ($R_{th(j-a)}$) strongly depends in the PCB design. Therefore, the thermal pad of the device should be attached to a big enough PCB copper area to ensure proper thermal dissipation (similar to JEDEC 51 standard). Several thermal vias in the PCB thermal pad should be used as well to increase the effectiveness of the heat dissipation (for example, 15 thermal vias). The thermal vias should be distributed evenly in the PCB thermal pad.

Finally, it is important to point out that this calculation should be taken as a reference only and therefore evaluations should still be performed under the application environment and conditions to confirm proper system operation.

10. Limiting values

Table 26. Limiting values

In accordance with the Absolute Maximum Rating System (IEC 60134).

Symbol	Parameter	Conditions	Min	Max	Unit
V_{DD}	supply voltage		-0.5	+6.0	V
$V_{I/O}$	voltage on an input/output pin		$V_{SS} - 0.5$	5.5	V
$V_{drv(LED)}$	LED driver voltage		$V_{SS} - 0.5$	20	V
$I_{O(LEDn)}$	output current on pin LEDn		-	65	mA
I_{SS}	ground supply current		-	1.0	A
P_{tot}	total power dissipation	$T_{amb} = 25 \text{ °C}$	-	2.56	W
		$T_{amb} = 85 \text{ °C}$	-	1.03	W
		$T_{amb} = 105 \text{ °C}$	-	0.513	W
T_{stg}	storage temperature		-65	+150	°C
T_{amb}	ambient temperature	operating for non AEC-Q100	-40	+105	°C
		operating for AEC-Q100	-40	+105	°C
T_j	junction temperature		-40	+125	°C

11. Thermal characteristics

Table 27. Thermal characteristics

Symbol	Parameter	Conditions	Typ	Unit
$R_{th(j-a)}$	thermal resistance from junction to ambient	HTSSOP28	[1] 39	°C/W

[1] Per JEDEC 51 standard for multilayer PCB and Wind Speed (m/s) = 0.

12. Static characteristics

Table 28. Static characteristics

$V_{DD} = 3\text{ V to }5.5\text{ V}$; $V_{SS} = 0\text{ V}$; $T_{amb} = -40\text{ °C to }+105\text{ °C}$; unless otherwise specified.

Symbol	Parameter	Conditions	Min	Typ ^[1]	Max	Unit	
Supply							
V_{DD}	supply voltage		3	-	5.5	V	
I_{DD}	supply current	on pin V_{DD} ; operating mode; $f_{SCLK} = 25\text{ MHz}$					
		$R_{ext} = 2\text{ k}\Omega$; LED[15:0] = off; IREF _x = 00h	-	11	12	mA	
		$R_{ext} = 1\text{ k}\Omega$; LED[15:0] = off; IREF _x = 00h	-	13	14	mA	
		$R_{ext} = 2\text{ k}\Omega$; LED[15:0] = on; IREF _x = FFh	-	15	19	mA	
		$R_{ext} = 1\text{ k}\Omega$; LED[15:0] = on; IREF _x = FFh	-	17	21	mA	
I_{stb}	standby current	on pin V_{DD} ; no load; $f_{SCLK} = 0\text{ Hz}$; MODE1[4] = 1; $V_I = V_{DD}$					
		$V_{DD} = 3.3\text{ V}$	-	170	600	μA	
		$V_{DD} = 5.5\text{ V}$	-	170	700	μA	
V_{POR}	power-on reset voltage	no load; $V_I = V_{DD}$ or V_{SS}	-	2	-	V	
V_{PDR}	power-down reset voltage	no load; $V_I = V_{DD}$ or V_{SS}	[2] [3]	1	-	V	
Inputs CS, SDI, SCLK; output SDO							
V_{IL}	LOW-level input voltage		-0.5	-	+0.3 V_{DD}	V	
V_{IH}	HIGH-level input voltage		0.7 V_{DD}	-	5.5	V	
V_{OH}	HIGH-level output voltage	$I_{OH} = -3\text{ mA}$ at SDO	$V_{DD} - 0.5$	-	-	V	
V_{OL}	LOW-level output voltage	$I_{OL} = 3\text{ mA}$ at SDO	-	-	0.5	V	
I_L	leakage current	$V_I = V_{DD}$ or V_{SS}	-1	-	+1	μA	
C_i	input capacitance	$V_I = V_{SS}$	-	6	10	pF	
Current controlled outputs (LED[15:0])							
$I_{O(LEDn)}$	output current on pin LED _n	$V_O = 0.8\text{ V}$; IREF _x = 80h; $R_{ext} = 1\text{ k}\Omega$	25	-	30	mA	
		$V_O = 0.8\text{ V}$; IREF _x = FFh; $R_{ext} = 1\text{ k}\Omega$	[3]	50	-	60	mA
ΔI_O	output current variation	$V_{DD} = 3.0\text{ V}$; $T_{amb} = 25\text{ °C}$; $V_O = 0.8\text{ V}$; IREF _x = 80h; $R_{ext} = 1\text{ k}\Omega$; guaranteed by design					
		between bits (different ICs, same channel)	[4]	-	-	± 6	%
		between bits (2 channels, same IC)	[5]	-	-	± 4	%
$V_{reg(drv)}$	driver regulation voltage	minimum regulation voltage; IREF _x = FFh; $R_{ext} = 1\text{ k}\Omega$	0.8	1	20	V	
$I_{L(off)}$	off-state leakage current	$V_O = 20\text{ V}$	-	-	1	μA	
V_{trip}	trip voltage	short LED protection; Error flag will trip during verification test if $V_O \geq V_{trip}$; $R_{ext} = 1\text{ k}\Omega$	2.7	2.85	-	V	

Table 28. Static characteristics ...continued

$V_{DD} = 3\text{ V to }5.5\text{ V}$; $V_{SS} = 0\text{ V}$; $T_{amb} = -40\text{ }^{\circ}\text{C to }+105\text{ }^{\circ}\text{C}$; unless otherwise specified.

Symbol	Parameter	Conditions	Min	Typ ^[1]	Max	Unit	
OE input, RESET input							
V_{IL}	LOW-level input voltage		-0.5	-	+0.3 V_{DD}	V	
V_{IH}	HIGH-level input voltage		0.7 V_{DD}	-	5.5	V	
I_{LI}	input leakage current		-1	-	+1	μA	
C_i	input capacitance		[3]	-	3.7	5	pF
Overtemperature protection							
$T_{th(otp)}$	overtemperature protection threshold temperature	rising	[3]	130	-	150	$^{\circ}\text{C}$
		hysteresis	[3]	15	-	30	$^{\circ}\text{C}$

- [1] Typical limits at $V_{DD} = 3.3\text{ V}$, $T_{amb} = 25\text{ }^{\circ}\text{C}$.
- [2] V_{DD} must be lowered to 1 V in order to reset part.
- [3] Value not tested in production, but guaranteed by design and characterization.
- [4] Part-to-part mismatch is calculated:

$$\Delta\% = \left(\frac{\left(\frac{I_{O(LED0)} + I_{O(LED1)} + \dots + I_{O(LED14)} + I_{O(LED15)}}{16} - \text{ideal output current} \right)}{\text{ideal output current}} \right) \times 100$$

where 'ideal output current' = 28.68 mA ($R_{ext} = 1\text{ k}\Omega$, $I_{REFx} = 80\text{h}$).

- [5] Channel-to-channel mismatch is calculated:

$$\Delta\% = \left(\frac{I_{O(LEDn)} \text{ (where } n = 0 \text{ to } 15)}{\left(\frac{I_{O(LED0)} + I_{O(LED1)} + \dots + I_{O(LED14)} + I_{O(LED15)}}{16} \right)} - 1 \right) \times 100$$

13. Dynamic characteristics

Table 29. Dynamic characteristics^[1]

Symbol	Parameter	Conditions	Min	Typ	Max	Unit
f_{SCLK}	SCLK clock frequency		0	-	25	MHz
t_{LOW}	LOW period of the SCLK clock		20	-	-	ns
t_{HIGH}	HIGH period of the SCLK clock		20	-	-	ns
t_{DS}	data set-up time		10	-	-	ns
t_{DH}	data hold time		0	-	-	ns
t_{CSS}	chip select asserted to SCLK rise set-up time		10	-	-	ns
t_{CSH}	SCLK fall to chip select de-asserted hold time		0	-	-	ns
t_{CS_HI}	minimum chip select de-asserted HIGH time		40	-	-	ns
$t_d(SDO)$	SDO delay time	$C_L = 50 \text{ pF}$	-	-	20	ns

[1] All parameters tested at $V_{DD} = 3 \text{ V to } 5.5 \text{ V}$; $V_{SS} = 0 \text{ V}$; $T_{amb} = +25 \text{ }^\circ\text{C}$. Specifications over temperature are guaranteed by design.

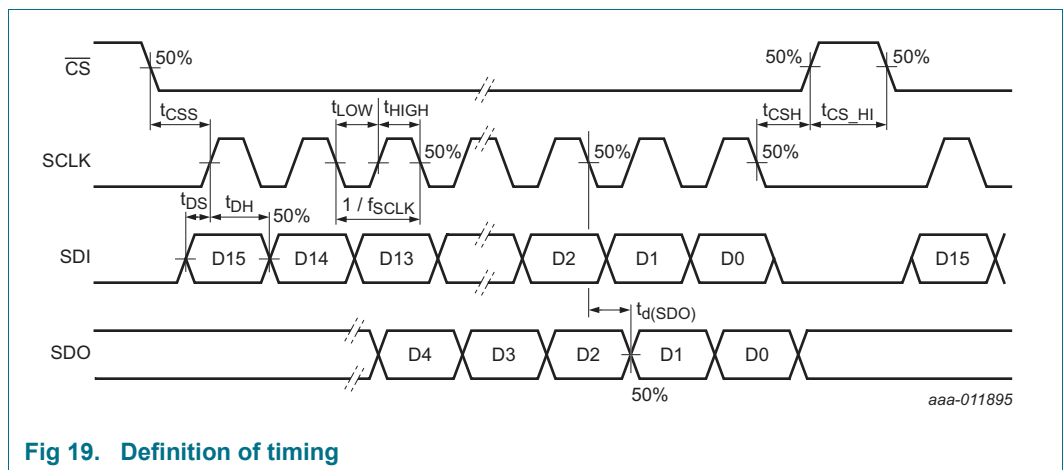

Fig 19. Definition of timing

14. Test information

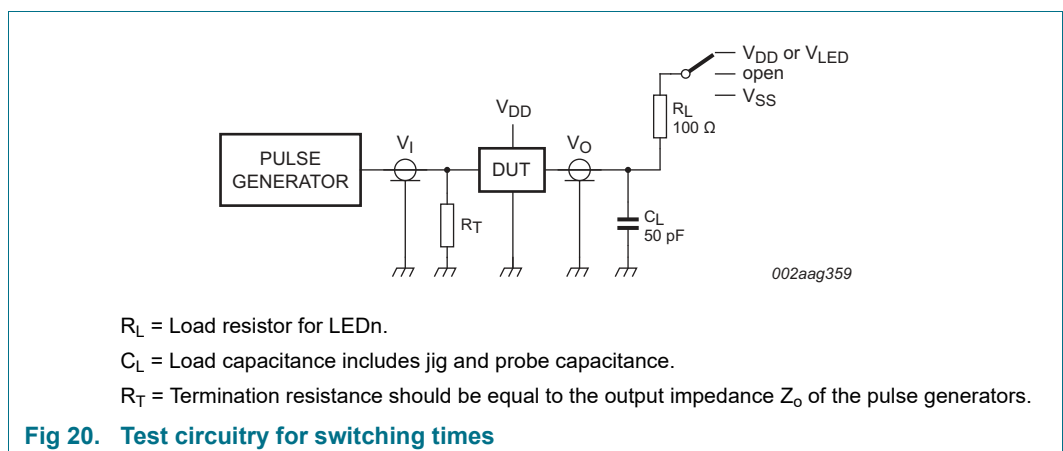

Fig 20. Test circuitry for switching times

15. Package outline

HTSSOP28: plastic thermal enhanced thin shrink small outline package; 28 leads; body width 4.4 mm; lead pitch 0.65 mm; exposed die pad

SOT1172-3

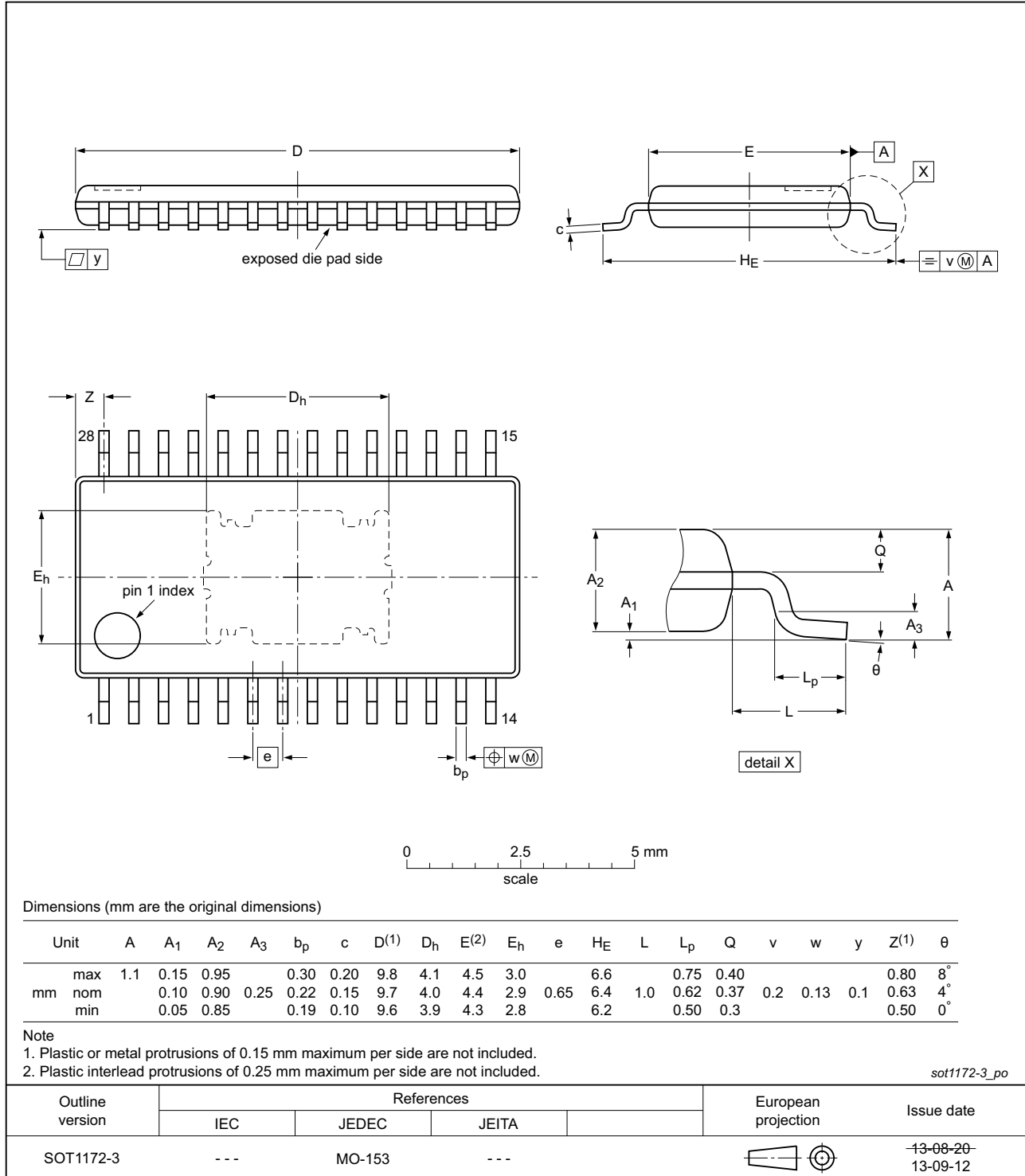

Fig 21. Package outline SOT1172-3 (HTSSOP28)

16. Handling information

All input and output pins are protected against ElectroStatic Discharge (ESD) under normal handling. When handling ensure that the appropriate precautions are taken as described in *JESD625-A* or equivalent standards.

17. Soldering of SMD packages

This text provides a very brief insight into a complex technology. A more in-depth account of soldering ICs can be found in Application Note *AN10365 "Surface mount reflow soldering description"*.

17.1 Introduction to soldering

Soldering is one of the most common methods through which packages are attached to Printed Circuit Boards (PCBs), to form electrical circuits. The soldered joint provides both the mechanical and the electrical connection. There is no single soldering method that is ideal for all IC packages. Wave soldering is often preferred when through-hole and Surface Mount Devices (SMDs) are mixed on one printed wiring board; however, it is not suitable for fine pitch SMDs. Reflow soldering is ideal for the small pitches and high densities that come with increased miniaturization.

17.2 Wave and reflow soldering

Wave soldering is a joining technology in which the joints are made by solder coming from a standing wave of liquid solder. The wave soldering process is suitable for the following:

- Through-hole components
- Leaded or leadless SMDs, which are glued to the surface of the printed circuit board

Not all SMDs can be wave soldered. Packages with solder balls, and some leadless packages which have solder lands underneath the body, cannot be wave soldered. Also, leaded SMDs with leads having a pitch smaller than ~0.6 mm cannot be wave soldered, due to an increased probability of bridging.

The reflow soldering process involves applying solder paste to a board, followed by component placement and exposure to a temperature profile. Leaded packages, packages with solder balls, and leadless packages are all reflow solderable.

Key characteristics in both wave and reflow soldering are:

- Board specifications, including the board finish, solder masks and vias
- Package footprints, including solder thieves and orientation
- The moisture sensitivity level of the packages
- Package placement
- Inspection and repair
- Lead-free soldering versus SnPb soldering

17.3 Wave soldering

Key characteristics in wave soldering are:

- Process issues, such as application of adhesive and flux, clinching of leads, board transport, the solder wave parameters, and the time during which components are exposed to the wave
- Solder bath specifications, including temperature and impurities

17.4 Reflow soldering

Key characteristics in reflow soldering are:

- Lead-free versus SnPb soldering; note that a lead-free reflow process usually leads to higher minimum peak temperatures (see [Figure 22](#)) than a SnPb process, thus reducing the process window
- Solder paste printing issues including smearing, release, and adjusting the process window for a mix of large and small components on one board
- Reflow temperature profile; this profile includes preheat, reflow (in which the board is heated to the peak temperature) and cooling down. It is imperative that the peak temperature is high enough for the solder to make reliable solder joints (a solder paste characteristic). In addition, the peak temperature must be low enough that the packages and/or boards are not damaged. The peak temperature of the package depends on package thickness and volume and is classified in accordance with [Table 30](#) and [31](#)

Table 30. SnPb eutectic process (from J-STD-020D)

Package thickness (mm)	Package reflow temperature (°C)	
	Volume (mm ³)	
	< 350	≥ 350
< 2.5	235	220
≥ 2.5	220	220

Table 31. Lead-free process (from J-STD-020D)

Package thickness (mm)	Package reflow temperature (°C)		
	Volume (mm ³)		
	< 350	350 to 2000	> 2000
< 1.6	260	260	260
1.6 to 2.5	260	250	245
> 2.5	250	245	245

Moisture sensitivity precautions, as indicated on the packing, must be respected at all times.

Studies have shown that small packages reach higher temperatures during reflow soldering, see [Figure 22](#).

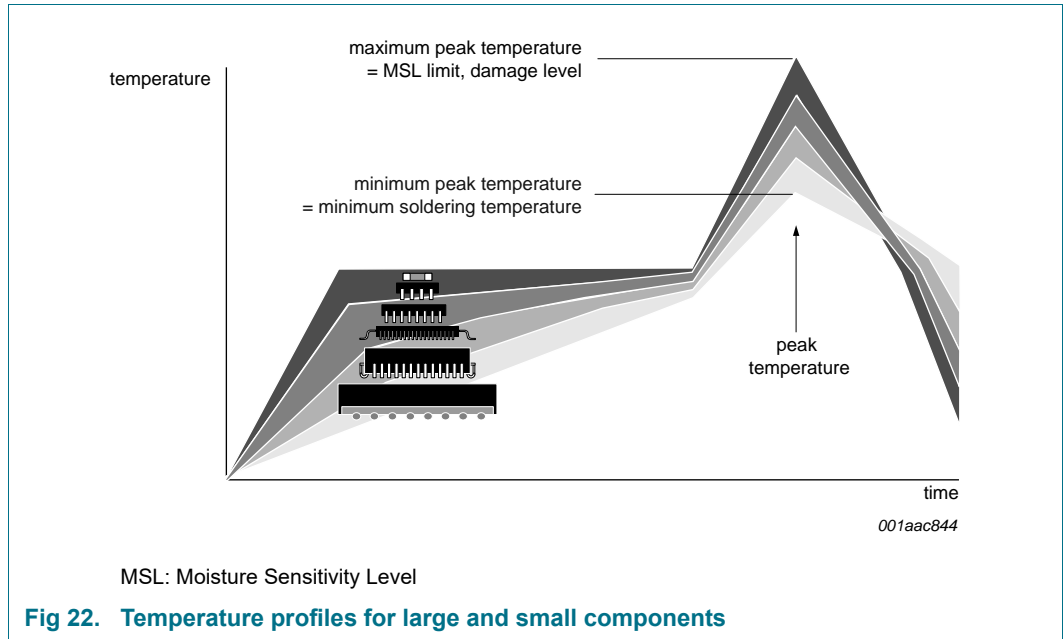

For further information on temperature profiles, refer to Application Note AN10365 “Surface mount reflow soldering description”.

18. Soldering: PCB footprints

Footprint information for reflow soldering of HTSSOP28 package

SOT1172-3

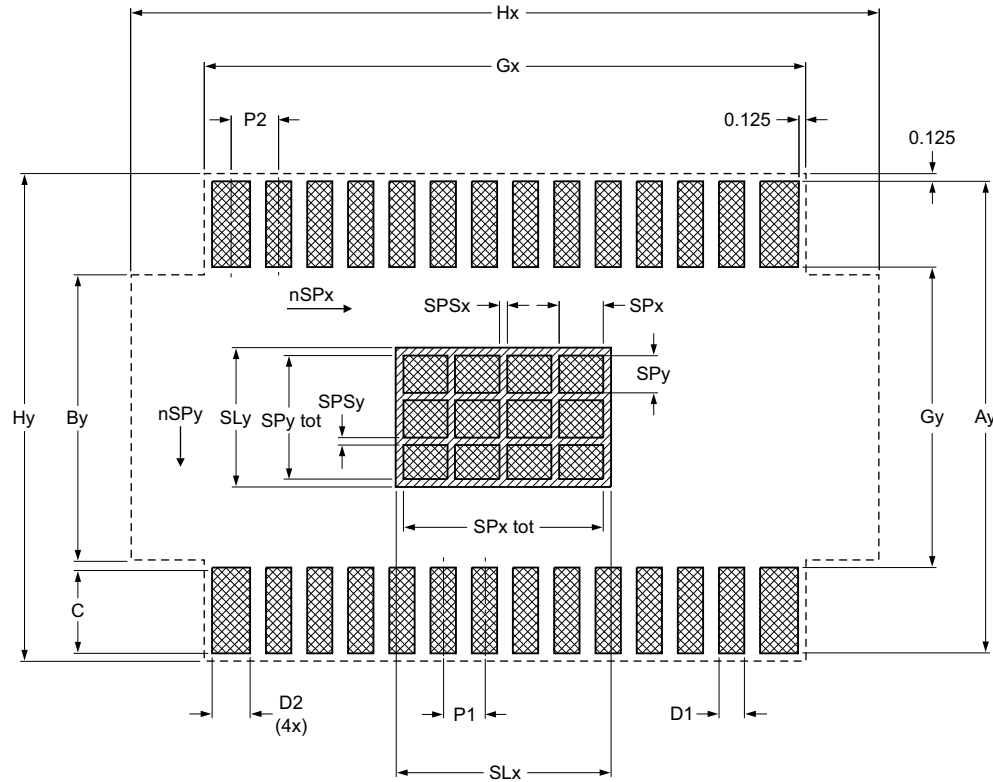

Generic footprint pattern
Refer to the package outline drawing for actual layout

- solder land
- solder land plus solder paste
- occupied area

SPSx	SPSy	nSPx	nSPy
0.120	0.100	4	3

DIMENSIONS in mm

P1	P2	Ay	By	C	D1	D2	SLx	SLy	SPx tot	SPy tot	SPx	SPy	Gx	Gy	Hx	Hy
0.65	0.75	7.45	4.50	1.35	0.40	0.60	3.40	2.20	3.16	2.00	0.70	0.60	9.50	4.75	11.80	7.70

Issue date ~~13-08-20~~
13-10-07

sot1172-3_fr

Fig 23. PCB footprint for SOT1172-3 (HTSSOP28); reflow soldering

19. Abbreviations

Table 32. Abbreviations

Acronym	Description
CDM	Charged-Device Model
DAC	Digital-to-Analog Converter
DUT	Device Under Test
ESD	ElectroStatic Discharge
FET	Field-Effect Transistor
HBM	Human Body Model
LED	Light Emitting Diode
LSB	Least Significant Bit
MCU	MicroController Unit
MISO	Master In, Slave Out
MOSI	Master Out, Slave In
MSB	Most Significant Bit
NMOS	Negative-channel Metal-Oxide Semiconductor
PCB	Printed-Circuit Board
PMOS	Positive-channel Metal-Oxide Semiconductor
PWM	Pulse Width Modulation
RGB	Red/Green/Blue
RGBA	Red/Green/Blue/Amber
SMBus	System Management Bus
SPI	Serial Peripheral Interface

20. Revision history

Table 33. Revision history

Document ID	Release date	Data sheet status	Change notice	Supersedes
PCA9745B v.1.1	20200610	Product data sheet	202005012I	PCA9745B v.1
Modifications:	<ul style="list-style-type: none"> Section 2, Section 7.2.12.1, Section 7.2.13: Added clarification regarding size of R_{ext} at which the LED open/short detection no longer works 			
PCA9745B v.1	20160616	Product data sheet	-	-

21. Legal information

21.1 Data sheet status

Document status ^{[1][2]}	Product status ^[3]	Definition
Objective [short] data sheet	Development	This document contains data from the objective specification for product development.
Preliminary [short] data sheet	Qualification	This document contains data from the preliminary specification.
Product [short] data sheet	Production	This document contains the product specification.

[1] Please consult the most recently issued document before initiating or completing a design.

[2] The term 'short data sheet' is explained in section "Definitions".

[3] The product status of device(s) described in this document may have changed since this document was published and may differ in case of multiple devices. The latest product status information is available on the Internet at URL <http://www.nxp.com>.

21.2 Definitions

Draft — The document is a draft version only. The content is still under internal review and subject to formal approval, which may result in modifications or additions. NXP Semiconductors does not give any representations or warranties as to the accuracy or completeness of information included herein and shall have no liability for the consequences of use of such information.

Short data sheet — A short data sheet is an extract from a full data sheet with the same product type number(s) and title. A short data sheet is intended for quick reference only and should not be relied upon to contain detailed and full information. For detailed and full information see the relevant full data sheet, which is available on request via the local NXP Semiconductors sales office. In case of any inconsistency or conflict with the short data sheet, the full data sheet shall prevail.

Product specification — The information and data provided in a Product data sheet shall define the specification of the product as agreed between NXP Semiconductors and its customer, unless NXP Semiconductors and customer have explicitly agreed otherwise in writing. In no event however, shall an agreement be valid in which the NXP Semiconductors product is deemed to offer functions and qualities beyond those described in the Product data sheet.

21.3 Disclaimers

Limited warranty and liability — Information in this document is believed to be accurate and reliable. However, NXP Semiconductors does not give any representations or warranties, expressed or implied, as to the accuracy or completeness of such information and shall have no liability for the consequences of use of such information. NXP Semiconductors takes no responsibility for the content in this document if provided by an information source outside of NXP Semiconductors.

In no event shall NXP Semiconductors be liable for any indirect, incidental, punitive, special or consequential damages (including - without limitation - lost profits, lost savings, business interruption, costs related to the removal or replacement of any products or rework charges) whether or not such damages are based on tort (including negligence), warranty, breach of contract or any other legal theory.

Notwithstanding any damages that customer might incur for any reason whatsoever, NXP Semiconductors' aggregate and cumulative liability towards customer for the products described herein shall be limited in accordance with the *Terms and conditions of commercial sale* of NXP Semiconductors.

Right to make changes — NXP Semiconductors reserves the right to make changes to information published in this document, including without limitation specifications and product descriptions, at any time and without notice. This document supersedes and replaces all information supplied prior to the publication hereof.

Suitability for use — NXP Semiconductors products are not designed, authorized or warranted to be suitable for use in life support, life-critical or safety-critical systems or equipment, nor in applications where failure or malfunction of an NXP Semiconductors product can reasonably be expected to result in personal injury, death or severe property or environmental damage. NXP Semiconductors and its suppliers accept no liability for inclusion and/or use of NXP Semiconductors products in such equipment or applications and therefore such inclusion and/or use is at the customer's own risk.

Applications — Applications that are described herein for any of these products are for illustrative purposes only. NXP Semiconductors makes no representation or warranty that such applications will be suitable for the specified use without further testing or modification.

Customers are responsible for the design and operation of their applications and products using NXP Semiconductors products, and NXP Semiconductors accepts no liability for any assistance with applications or customer product design. It is customer's sole responsibility to determine whether the NXP Semiconductors product is suitable and fit for the customer's applications and products planned, as well as for the planned application and use of customer's third party customer(s). Customers should provide appropriate design and operating safeguards to minimize the risks associated with their applications and products.

NXP Semiconductors does not accept any liability related to any default, damage, costs or problem which is based on any weakness or default in the customer's applications or products, or the application or use by customer's third party customer(s). Customer is responsible for doing all necessary testing for the customer's applications and products using NXP Semiconductors products in order to avoid a default of the applications and the products or of the application or use by customer's third party customer(s). NXP does not accept any liability in this respect.

Limiting values — Stress above one or more limiting values (as defined in the Absolute Maximum Ratings System of IEC 60134) will cause permanent damage to the device. Limiting values are stress ratings only and (proper) operation of the device at these or any other conditions above those given in the Recommended operating conditions section (if present) or the Characteristics sections of this document is not warranted. Constant or repeated exposure to limiting values will permanently and irreversibly affect the quality and reliability of the device.

Terms and conditions of commercial sale — NXP Semiconductors products are sold subject to the general terms and conditions of commercial sale, as published at <http://www.nxp.com/profile/terms>, unless otherwise agreed in a valid written individual agreement. In case an individual agreement is concluded only the terms and conditions of the respective agreement shall apply. NXP Semiconductors hereby expressly objects to applying the customer's general terms and conditions with regard to the purchase of NXP Semiconductors products by customer.

No offer to sell or license — Nothing in this document may be interpreted or construed as an offer to sell products that is open for acceptance or the grant, conveyance or implication of any license under any copyrights, patents or other industrial or intellectual property rights.

Export control — This document as well as the item(s) described herein may be subject to export control regulations. Export might require a prior authorization from competent authorities.

Non-automotive qualified products — Unless this data sheet expressly states that this specific NXP Semiconductors product is automotive qualified, the product is not suitable for automotive use. It is neither qualified nor tested in accordance with automotive testing or application requirements. NXP Semiconductors accepts no liability for inclusion and/or use of non-automotive qualified products in automotive equipment or applications.

In the event that customer uses the product for design-in and use in automotive applications to automotive specifications and standards, customer (a) shall use the product without NXP Semiconductors' warranty of the product for such automotive applications, use and specifications, and (b) whenever customer uses the product for automotive applications beyond

NXP Semiconductors' specifications such use shall be solely at customer's own risk, and (c) customer fully indemnifies NXP Semiconductors for any liability, damages or failed product claims resulting from customer design and use of the product for automotive applications beyond NXP Semiconductors' standard warranty and NXP Semiconductors' product specifications.

Translations — A non-English (translated) version of a document is for reference only. The English version shall prevail in case of any discrepancy between the translated and English versions.

21.4 Trademarks

Notice: All referenced brands, product names, service names and trademarks are the property of their respective owners.

22. Contact information

For more information, please visit: <http://www.nxp.com>

For sales office addresses, please send an email to: salesaddresses@nxp.com

23. Contents

1	General description	1	7.2.13.1	Open-circuit detection principle	27
2	Features and benefits	2	7.2.13.2	Short-circuit detection principle	27
3	Applications	3	7.2.14	Overtemperature protection	27
4	Ordering information	3	7.3	Active LOW output enable input	28
4.1	Ordering options	3	7.4	Power-on reset	28
5	Block diagram	4	7.5	Hardware reset recovery	28
6	Pinning information	5	7.6	Individual brightness control with group dimming/blinking	29
6.1	Pinning	5	8	Characteristics of the 4-wire serial-bus interface	30
6.2	Pin description	5	8.1	SPI-compatible 4-wire serial interface signals	30
7	Functional description	6	8.2	Data format	31
7.1	Register address and data	6	8.3	Write access sequence	31
7.2	Register definitions	6	8.4	Read access sequence	32
7.2.1	MODE1 — Mode register 1	9	8.5	Overlapped read and write access sequence	33
7.2.2	MODE2 — Mode register 2	9	9	Application design-in information	34
7.2.3	LEDOUT0 to LEDOUT3, LED driver output state	11	9.1	Thermal considerations	34
7.2.4	GRPPWM, group duty cycle control	11	10	Limiting values	36
7.2.5	GRPFREQ, group frequency	12	11	Thermal characteristics	36
7.2.6	PWM0 to PWM15, individual brightness control	12	12	Static characteristics	37
7.2.7	IREF0 to IREF15, LED output current value registers	13	13	Dynamic characteristics	39
7.2.8	Gradation control	14	14	Test information	39
7.2.8.1	RAMP_RATE_GRP0 to RAMP_RATE_GRP3, ramp rate control registers	15	15	Package outline	40
7.2.8.2	STEP_TIME_GRP0 to STEP_TIME_GRP3, step time control registers	15	16	Handling information	41
7.2.8.3	HOLD_CNTL_GRP0 to HOLD_CNTL_GRP3, hold ON and OFF control registers	16	17	Soldering of SMD packages	41
7.2.8.4	IREF_GRP0 to IREF_GRP3, output gain control	16	17.1	Introduction to soldering	41
7.2.8.5	GRAD_MODE_SEL0 to GRAD_MODE_SEL1, Gradation mode select registers	17	17.2	Wave and reflow soldering	41
7.2.8.6	GRAD_GRP_SEL0 to GRAD_GRP_SEL3, Gradation group select registers	17	17.3	Wave soldering	41
7.2.8.7	GRAD_CNTL, Gradation control register	18	17.4	Reflow soldering	42
7.2.8.8	Ramp control — equation and calculation example	19	18	Soldering: PCB footprints	44
7.2.9	OFFSET — LEDn output delay offset register	22	19	Abbreviations	45
7.2.10	PWMALL — brightness control for all LEDn outputs	23	20	Revision history	45
7.2.11	IREFALL register: output current value for all LED outputs	23	21	Legal information	46
7.2.12	LED driver constant current outputs	23	21.1	Data sheet status	46
7.2.12.1	Adjusting output current	23	21.2	Definitions	46
7.2.13	LED error detection	26	21.3	Disclaimers	46
			21.4	Trademarks	47
			22	Contact information	47
			23	Contents	48

Please be aware that important notices concerning this document and the product(s) described herein, have been included in section 'Legal information'.

© NXP B.V. 2020. All rights reserved.

For more information, please visit: <http://www.nxp.com>
 For sales office addresses, please send an email to: salesaddresses@nxp.com

Date of release: 10 June 2020
 Document identifier: PCA9745B