

REVISIONS					
REV	ECO	DESCRIPTION	DATE	BY	APPR
A1	-	RELEASE NEW DRAWING	15JUN18	RIMON	TOMMY
A2	C0937S	UPDATE COLOUR	5SEP18	PETER	TOMMY
A3	C0964S	INCREASE THE ROUND CORNER OF ARM AND CHANGE THE MATERIAL	19DEC18	PETER	TOMMY

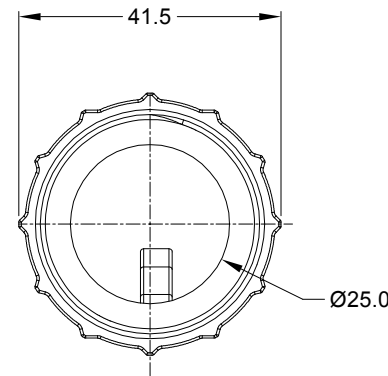
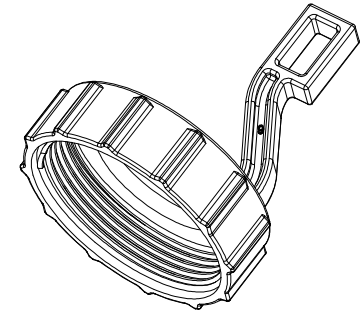
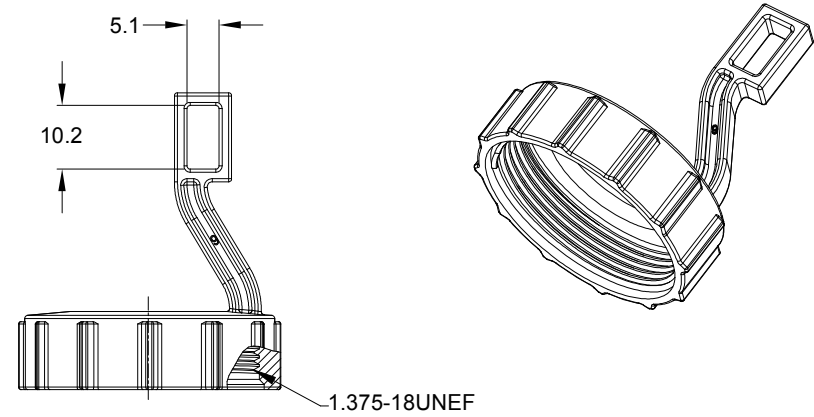
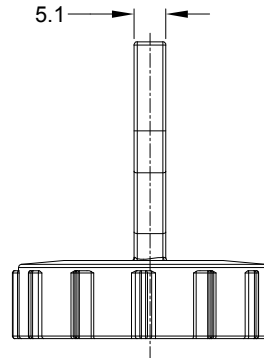
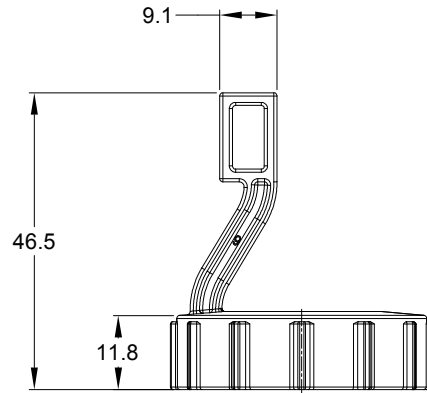

NOTES: UNLESS OTHERWISE SPECIFIED

1. MATERIAL: THERMOPLASTIC; COLOR: GRAY
2. COMPATIBLE WITH AHD 9 POSITION.
3. RoHS COMPLIANT.
4. ALL DIMENSIONS ARE FOR REFERENCE USE ONLY.

TITLE: STRAIN RELIEF AHD 9 PIN TY-RAP
 DWG NO.: AHD18-009
 REV: A3
 SH: 1
 OF: 1

AHD18-009		DESCRIPTION		ITEM								
PART NUMBER												
QUANTITY	MATERIALS LIST											
UNLESS OTHERWISE SPECIFIED:		SIGNATURES	DATE	<p>Sine Systems - www.amphenol-sine.com 44724 Morley Drive Clinton Township, MI 48036</p>								
1) All dimensions are in metric(mm).		DRAWN: PETER YANG	19DEC18									
2) Tolerances are as follows:		CHECKED: ORION LI	19DEC18									
1 PL DEC ±0.30 2 PL DEC ±0.15 3 PL DEC ±0.08		ENGINEER:										
3) Note reference =		APPROVAL: TOMMY XIE	19DEC18									
MATERIAL SPECIFICATIONS:		CUSTOMER:		STRAIN RELIEF AHD 9 PIN TY-RAP								
PROCESS SPECIFICATIONS:		THIS DRAWING IS SUPPLIED FOR INFORMATION ONLY. DESIGN FEATURES, SPECIFICATIONS AND PERFORMANCE DATA SHOWN HEREON ARE THE PROPERTY OF THE AMPHENOL CORPORATION. NO RIGHTS OF REPRODUCTION ARE IMPLIED. ALL DIMENSIONS ARE SUBJECT TO NORMAL MANUFACTURING VARIATIONS.		<table border="1"> <tr> <td>SIZE</td> <td>TYPE</td> <td>DWG NO:</td> <td>REVISION</td> </tr> <tr> <td>B</td> <td>C-</td> <td>AHD18-009</td> <td>A3</td> </tr> </table>	SIZE	TYPE	DWG NO:	REVISION	B	C-	AHD18-009	A3
SIZE	TYPE	DWG NO:	REVISION									
B	C-	AHD18-009	A3									
NEXT ASSY:		SCALE: NONE	SHEET 1 OF 1									