

±2g/±4g/±8g Three Axis Low-g Digital Output Accelerometer

The MMA7456L is a Digital Output (I²C/SPI), low power, low profile capacitive micromachined accelerometer featuring signal conditioning, a low pass filter, temperature compensation, self-test, configurable to detect 0g through interrupt pins (INT1 or INT2), and pulse detect for quick motion detection. 0g offset and sensitivity are factory set and require no external devices. The 0g offset can be customer calibrated using assigned 0g registers and g-Select which allows for command selection for 3 acceleration ranges (2g/4g/8g). The MMA7456L includes a Standby Mode that makes it ideal for handheld battery powered electronics.

Features

- Digital Output (I²C/SPI)
- 3mm x 5mm x 1mm LGA-14 Package
- Self-Test for Z-Axis
- Low Voltage Operation: 2.4 V – 3.6 V
- User Assigned Registers for Offset Calibration
- Programmable Threshold Interrupt Output
- Level Detection for Motion Recognition (Shock, Vibration, Freefall)
- Pulse Detection for Single or Double Pulse Recognition
- Sensitivity (64 LSB/g @ 2g and @ 8g in 10-Bit Mode)
- Selectable Sensitivity (±2g, ±4g, ±8g) for 8-bit Mode
- Robust Design, High Shocks Survivability (5,000g)
- RoHS Compliant
- Environmentally Preferred Product
- Low Cost

Typical Applications

- Cell Phone/PMP/PDA: Image Stability, Text Scroll, Motion Dialing, Tap to Mute
- HDD: Freefall Detection
- Laptop PC: Freefall Detection, Anti-Theft
- Pedometer
- Motion Sensing, Event Recorder

ORDERING INFORMATION			
Part Number	Temperature Range	Package	Shipping
MMA7456LT	-40 to +85°C	LGA-14	Tray
MMA7456LR1	-40 to +85°C	LGA-14	7" Tape & Reel
MMA7456LR2	-40 to +85°C	LGA-14	13" Tape & Reel

MMA7456L

**MMA7456L: XYZ-AXIS
ACCELEROMETER
±2g/±4g/±8g**

Bottom View

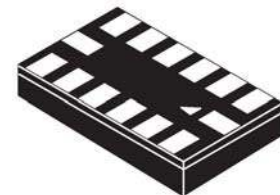

**14 LEAD
LGA
CASE 1977-01**

Top View

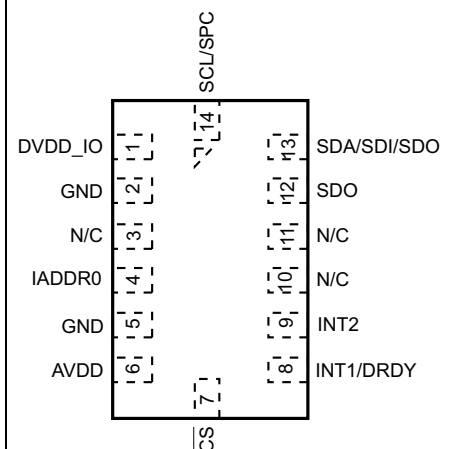

Figure 1. Pin Connections

Contents

ELECTRO STATIC DISCHARGE (ESD)	6
PRINCIPLE OF OPERATION	8
FEATURES	9
Self-Test	9
g-Select	9
Standby Mode	9
Measurement Mode	9
Level Detection	10
\$18: Control 1 (Read/Write) Setting the Detection Axes for X, Y and Z	10
\$19: Control 2 (Read/Write) Motion Detection (OR Condition) or Freefall Detection (AND Condition)	10
\$18: Control 1 (Read/Write): Setting the threshold to be an integer value or an absolute value	10
\$1A: Level Detection Threshold Limit Value (Read/Write)	10
Threshold Detection for Motion and Freefall Conditions	11
CASE 1: Motion Detection	11
CASE 2: Motion Detection	11
CASE 3: Freefall Detection	11
CASE 4: Freefall Detection	11
Pulse Detection	12
\$18: Control 1 (Read/Write): Disable X, Y or Z for Pulse Detection	12
\$19: Control 2 (Read/Write): Motion Detection (OR condition) or Freefall Detection (AND condition)	12
CASE 1: Single Pulse Motion Detection: X or Y or Z > Pulse Threshold for Time < Pulse Duration	12
CASE 2: Freefall Detection: X and Y and Z < Pulse Threshold for Time > Latency Time	13
CASE 3: Double Pulse Detection: X OR Y OR Z > Threshold for Pulse Duration1 < PDTime1	14
Assigning, Clearing & Detecting Interrupts	15
Clearing the Interrupt Pins: Register \$17	15
Detecting Interrupts	16
Digital Interface	16
I ² C Slave Interface	16
SPI Slave Interface	18
BASIC CONNECTIONS	19
Pin Descriptions	19
Recommended PCB Layout for Interfacing Accelerometer to Microcontroller	19
Register Definitions	21
Soldering and Mounting Guidelines for the LGA Accelerometer Sensor to a PC Board	29

List of Figures

Pin Connections	1
Simplified Accelerometer Functional Block Diagram	5
Simplified Transducer Physical Model	8
Single Pulse Detection	13
Freefall Detection in Pulse Mode	13
Double Pulse Detection	14
Single Byte Read - The Master is reading one address from the MMA7456L	17
Multiple Bytes Read - The Master is reading multiple sequential registers from the MMA7456L	17
Single Byte Write - The Master (MCU) is writing to a single register of the MMA7456L	17
Multiple Byte Writes - The Master (MCU) is writing to multiple sequential registers of the MMA7456L	17
SPI Timing Diagram for 8-Bit Register Read (4 Wire Mode)	18
SPI Timing Diagram for 8-Bit Register Read (3 Wire Mode)	18
SPI Timing Diagram for 8-Bit Register Write (3 Wire Mode)	18
Pinout Description	19
I ² C Connection to MCU	19
SPI Connection to MCU	20
Sensing Direction and Output Response at 2g Mode	28
Recommended PCB Land Pattern for the 5 x 3 mm LGA Package	29
Incorrect PCB Top Metal Pattern Under Package	30
Correct PCB Top Metal Pattern Under Package	30
Recommended PCB Land Pad, Solder Mask, and Signal Trace Near Package Design	30
Stencil Design Guidelines	31
Temperature Coefficient of Offset (TCO) and Temperature Coefficient of Sensitivity (TCS) Distribution Charts	32
Current Distribution Charts	32

List of Tables

Pin Descriptions	5
Maximum Ratings	6
Operating Characteristics	7
Function Parameters for Detection	8
\$16: Mode Control Register (Read/Write)	9
Configuring the g-Select for 8-bit output using Register \$16 with GLVL[1:0] bits	9
Configuring the Mode using Register \$16 with MODE[1:0] bits	9
THOPT = 0 Absolute; THOPT = 1 Positive Negative	10
\$1B: Pulse Detection Threshold Limit Value (Read/Write)	12
\$1C: Pulse Duration Value (Read/Write)	12
\$1B: Pulse Detection Threshold Limit Value (Read/Write)	13
\$1D: Latency Time Value (Read/Write)	13
\$1B: Pulse Detection Threshold Limit Value (Read/Write)	14
\$1C: Pulse Duration Value (Read/Write)	14
\$1D: Latency Time Value (Read/Write)	14
\$1E: Time Window for 2nd Pulse Value (Read/Write)	14
\$18 Control 1 Register	15
Configuring the Interrupt settings using Register \$18 with INTREG[1:0] bits	15
\$17: Interrupt Latch Reset (Read/Write)	15
\$0A: Detection Source Register (Read only)	16
Pin Descriptions	19
User Register Summary	21
\$00: 10bits Output Value X LSB (Read only)	21
\$01: 10bits Output Value X MSB (Read only)	22
\$02: 10bits Output Value Y LSB (Read only)	22
\$03: 10bits Output Value Y MSB (Read only)	22
\$05: 10bits Output Value X MSB (Read only)	22
\$06: 8bits Output Value X (Read only)	22
\$07: 8bits Output Value Y (Read only)	22
\$08: 8bits Output Value Z (Read only)	23
\$09: Status Register (Read only)	23
\$0A: Detection Source Register (Read only)	23
\$0D: I2C Device Address (Bit 6-0: Read only, Bit 7: Read/Write)	23
\$0E: User Information (Read Only: Optional)	23
\$0F: "Who Am I" Value (Read only: Optional)	24
\$10: Offset Drift X LSB (Read/Write)	24
\$11: Offset Drift X MSB (Read/Write)	24
\$12: Offset Drift Y LSB (Read/Write)	24
\$13: Offset Drift Y MSB (Read/Write)	24
\$14: Offset Drift Z LSB (Read/Write)	24
\$15: Offset Drift Z MSB (Read/Write)	25
\$16: Mode Control Register (Read/Write)	25
Configuring the g-Select for 8-bit output using Register \$16 with GLVL[1:0] bits	25
Configuring the Mode using Register \$16 with MODE[1:0] bits	25
\$17: Interrupt Latch Reset (Read/Write)	26
\$18 Control 1 (Read/Write)	26
Configuring the Interrupt settings using Register \$18 with INTREG[1:0] bits	26
\$1A: Level Detection Threshold Limit Value (Read/Write)	27
\$1B: Pulse Detection Threshold Limit Value (Read/Write)	27
\$1C: Pulse Duration Value (Read/Write)	27
\$1D: Latency Time Value (Read/Write)	27
\$1E: Time Window for 2nd Pulse Value (Read/Write)	27
Acceleration vs. Output (8-bit data)	28

Table 1. Pin Descriptions

Pin #	Pin Name	Description	Pin Status
1	DVDD_IO	Digital Power for I/O pads	Input
2	GND	Ground	Input
3	N/C	No internal connection. Leave unconnected or connect to Ground.	Input
4	IADDR0	I ² C Address Bit 0 (optional)*	Input
5	GND	Ground	Input
6	AVDD	Analog Power	Input
7	$\overline{\text{CS}}$	SPI Enable (0), I ² C Enable (1)	Input
8	INT1/DRDY	Interrupt 1/ Data Ready	Output
9	INT2	Interrupt 2	Output
10	N/C	No internal connection. Leave unconnected or connect to Ground.	Input
11	N/C	Leave unconnected or connect to Ground.	Input
12	SDO	SPI Serial Data Output	Output
13	SDA/SDI/SDO	I ² C Serial Data (SDA), SPI Serial Data Input (SDI), 3-wire interface Serial Data Output (SDO)	Open Drain/Input/Output
14	SCL/SPC	I ² C Serial Clock (SCL), SPI Serial Clock (SPC)	Input

*This address selection capability is not enabled at the default state. If the user wants to use it, factory programming is required. If activated (pin 4 on the device is active).

<\$1D = 0001 1101 > bit 0 is V_{DD} on pin 4

<\$1C = 0001 1100 > bit 0 is GND on pin 4. If the pin is programmed it cannot be left NC.

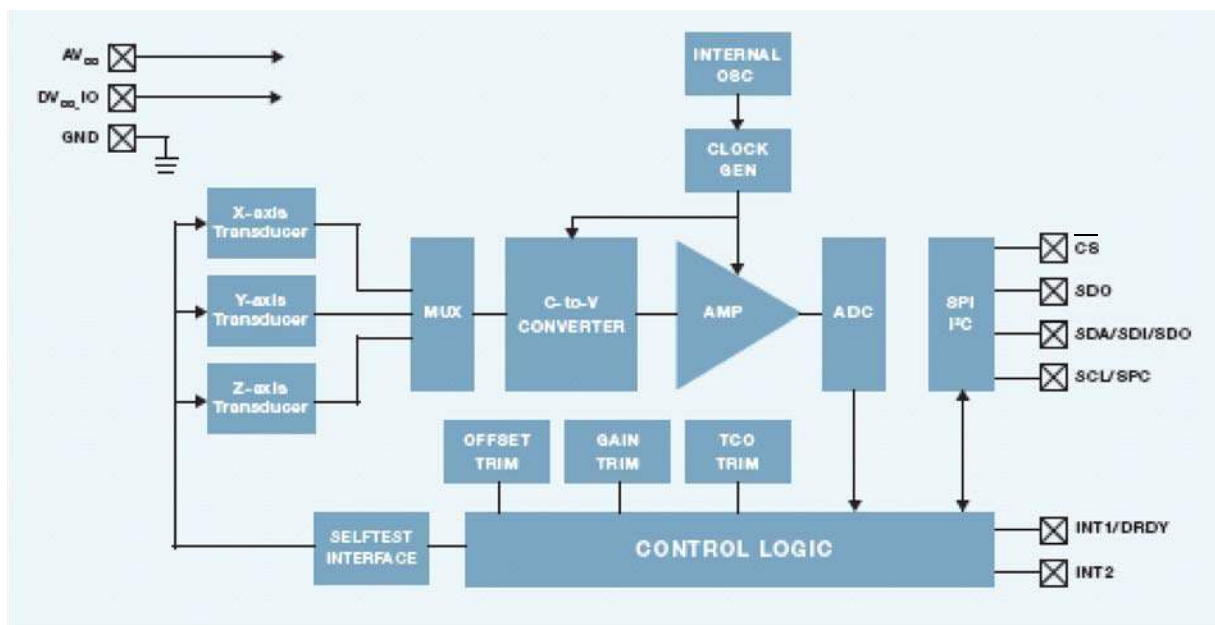

Figure 2. Simplified Accelerometer Functional Block Diagram

Table 2. Maximum Ratings

(Maximum ratings are the limits to which the device can be exposed without causing permanent damage.)

Rating	Symbol	Value	Unit
Maximum Acceleration (all axes)	g_{max}	5000	g
Analog Supply Voltage	AV_{DD}	-0.3 to +3.6	V
Digital I/O pins Supply Voltage	DV_{DD_IO}	-0.3 to +3.6	V
Drop Test	D_{drop}	1.8	m
Storage Temperature Range	T_{stg}	-40 to +125	°C

ELECTRO STATIC DISCHARGE (ESD)

WARNING: This device is sensitive to electrostatic discharge.

Although the Freescale accelerometer contains internal 2000V ESD protection circuitry, extra precaution must be taken by the user to protect the chip from ESD. A charge of over 2000 volts can accumulate on the human body or associated test equipment. A charge of this magnitude can alter the performance or cause failure of the chip. When handling the accelerometer, proper ESD precautions should be followed to avoid exposing the device to discharges which may be detrimental to its performance.

Table 3. Operating Characteristics

 Unless otherwise noted: $-40^{\circ}\text{C} \leq T_A \leq 85^{\circ}\text{C}$, $2.4\text{ V} \leq AV_{DD} \leq 3.6\text{ V}$, Acceleration = 0g, Loaded output.

Characteristic	Symbol	Min	Typ	Max	Unit
Analog Supply Voltage					
Standby/Operation Mode	AV_{DD}	2.4	2.8	3.6	V
Enable Bus Mode	AV_{DD}		0		V
Digital I/O Pins Supply Voltage					
Standby/Operation Mode	DV_{DD_IO}	1.71	1.8	AV_{DD}	V
Enable Bus Mode	DV_{DD_IO}	1.71	1.8	3.6	V
Supply Current Drain					
Operation Mode	I_{DD}	—	400	490	μA
Pulse Detect Function Mode	I_{DD}	—	400	490	μA
Standby Mode (except data loading and I ² C/SPI communication period)	I_{DD}	—	2.5	10	μA
Operating Temperature Range	T_A	-40	25	85	$^{\circ}\text{C}$
0g Output Signal ($T_A = 25^{\circ}\text{C}$, $V_{DD} = 2.8\text{ V}$)					
±2g range (25 $^{\circ}\text{C}$) 8bit		-18	0	18	count
±4g range (25 $^{\circ}\text{C}$) 8bit		-10	0	10	count
±8g range (25 $^{\circ}\text{C}$) 8bit		-5	0	5	count
±8g range (25 $^{\circ}\text{C}$) 10bit		-18	0	18	count
Sensitivity ($T_A = 25^{\circ}\text{C}$, $V_{DD} = 2.8\text{ V}$)					
±2g range (25 $^{\circ}\text{C}$) 8bit		58	64	70	count/g
±4g range (25 $^{\circ}\text{C}$) 8bit		29	32	35	count/g
±8g range (25 $^{\circ}\text{C}$) 8bit		14.5	16	17.5	count/g
±8g range (25 $^{\circ}\text{C}$) 10bit		58	64	70	count/g
Self-Test Output Response					
ZOUT (8g - 10bit)	ΔST_Z	32	64	83	count
Temperature Compensation for Offset	T_{CO}	±3.5	±0.5	+3.5	mg/ $^{\circ}\text{C}$
Temperature Sensitivity for Offset	T_{CS}	±0.026	±0.01	+0.026	mg/ $^{\circ}\text{C}$
Input High Voltage	V_{IH}	$0.7 \times DV_{DD}$	—	—	V
Input Low Voltage	V_{IL}	—	—	$0.35 \times DV_{DD}$	V
Internal Clock Frequency ($T_A = 25^{\circ}\text{C}$, $AV_{DD} = 2.8\text{ V}$)	t_{CLK}	140	150	160	kHz
SPI Frequency					
$DV_{DD_IO} < 2.4\text{ V}$		—	4	—	MHz
$DV_{DD_IO} > 2.4\text{ V}$		—	8	—	MHz
Bandwidth for Data Measurement (User Selectable)					
DFBW 0		—	62.5	—	Hz
DFBW 1		—	125	—	Hz
Output Data Rate					
Output Data Rate is 125 Hz when 62.5 bandwidth is selected.		—	125	—	Hz
Output Data rate is 250 Hz when 125Hz bandwidth is selected.		—	250	—	Hz
Control Timing					
Wait Time for I ² C/SPI ready after power on	t_{su}	—	1	—	ms
Turn On Response Time (Standby to Normal Mode)	t_{ru}	—	—	20	ms
Turn Off Response Time (Normal to Standby Mode)	t_{rd}	—	—	20	ms
Self-Test Response Time	t_{st}	—	—	20	ms
Sensing Element Resonant Frequency					
XY	$f_{GCELLXY}$	—	6.0	—	kHz
Z	f_{GCELLZ}	—	3.4	—	kHz
Nonlinearity (2 g range)		-1	—	+1	%FS
Cross Axis Sensitivity		-5	—	+5	%

Table 4. Function Parameters for Detection

$-40^{\circ}\text{C} \leq T_A \leq 85^{\circ}\text{C}$, $2.4\text{ V} \leq AV_{DD} \leq 3.6\text{ V}$, unless otherwise specified

Characteristic	Symbol	Min	Typ	Max	Unit
Level Detection					
Detection Threshold Range		0	—	FS	g
Pulse Detection					
Pulse detection range (Adjustable range)		0.5	—	127	ms
Time step for pulse detection		—	0.5	—	ms
Threshold range for pulses		0	—	FS	g
Detection levels for threshold		—	127	—	Counts
Latency timer (Adjustable range)		1	—	150	ms
Time Window (Adjustable range)		1	—	250	ms
Bandwidth for detecting interrupt*		—	600	—	Hz
Time step for latency timer and time window		—	1	—	ms

Note: The response time is between 10% of full scale V_{DD} input voltage and 90% of the final operating output voltage.

*The bandwidth for detecting interrupts in level and pulse is 600Hz which is changed from measurement mode.

PRINCIPLE OF OPERATION

The Freescale accelerometer is a surface-micromachined integrated-circuit accelerometer. The device consists of a surface micromachined capacitive sensing cell (g-cell) and a signal conditioning ASIC contained in a single package. The sensing element is sealed hermetically at the wafer level using a bulk micromachined cap wafer. The g-cell is a mechanical structure formed from semiconductor materials (polysilicon) using semiconductor processes (masking and etching). It can be modeled as a set of beams attached to a movable central mass that move between fixed beams. The movable beams can be deflected from their rest position by subjecting the system to an acceleration (Figure 3).

As the beams attached to the central mass move, the distance from them to the fixed beams on one side will increase by the same amount that the distance to the fixed beams on the other side decreases. The change in distance is a measure of acceleration. The g-cell beams form two back-to-back capacitors (Figure 3). As the center beam moves with acceleration, the distance between the beams changes and each capacitor's value will change, ($C = A\epsilon/D$). Where A is the area of the beam, ϵ is the dielectric constant, and D is the distance between the beams.

The ASIC uses switched capacitor techniques to measure the g-cell capacitors and extract the acceleration data from the difference between the two capacitors. The ASIC also signal conditions and filters (switched capacitor) the signal, providing a digital output that is proportional to acceleration.

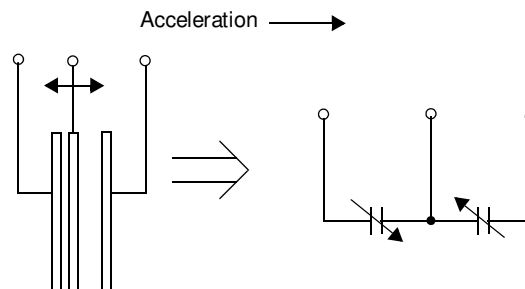

Figure 3. Simplified Transducer Physical Model

FEATURES

Self-Test

The sensor provides a self-test feature that allows the verification of the mechanical and electrical integrity of the accelerometer at any time before or after installation. This feature is critical in applications such as hard disk drive protection where system integrity must be ensured over the life of the product. When the self-test function is initiated through the mode control register (\$16), accessing the “self-test” bit, an electrostatic force is applied to each axis to cause it to deflect. The Z-axis is trimmed to deflect 1g. This procedure assures that both the mechanical (g-cell) and electronic sections of the accelerometer are functioning.

g-Select

The g-Select feature enables the selection between 3 acceleration ranges for measurement. Depending on the values in the Mode control register (\$16), the MMA7456L's internal gain will be changed allowing it to function with a 2g, 4g or 8g measurement sensitivity. This feature is ideal when a product has applications requiring two or more acceleration ranges for optimum performance and for enabling multiple functions. The sensitivity can be changed during the operation by modifying the two GLVL bits located in the mode control register.

\$16: Mode Control Register (Read/Write)

D7	D6	D5	D4	D3	D2	D1	D0	Bit
--	DRPD	SPI3W	STON	GLVL[1]	GLVL[0]	MODE[1]	MODE[0]	Function
0	0	0	0	0	0	0	0	Default

Table 5. Configuring the g-Select for 8-bit output using Register \$16 with GLVL[1:0] bits

GLVL [1:0]	g-Range	Sensitivity
00	8g	16 LSB/g
01	2g	64 LSB/g
10	4g	32 LSB/g

Standby Mode

This digital output 3-axis accelerometer provides a standby mode that is ideal for battery operated products. When standby mode is active, the device outputs are turned off, providing significant reduction of operating current. When the device is in standby mode the current will be reduced to 2.5 μ A typical. In standby mode the device can read and write to the registers with the I²C/SPI available, but no new measurements can be taken in this mode as all current consuming parts are off. The mode of the device is controlled through the mode control register by accessing the two mode bits as shown in [Table 6](#).

Table 6. Configuring the Mode using Register \$16 with MODE[1:0] bits

MODE [1:0]	Function
00	Standby Mode
01	Measurement Mode
10	Level Detection Mode
11	Pulse Detection Mode

Measurement Mode

During measurement mode, continuous measurements on all three axes enabled. The g-range for 2g, 4g, or 8g are selectable with 8-bit data and the g-range of 8g is selectable with 10-bit data. The sample rate during measurement mode is 125 Hz with 62.5 BW filter selected. The sample rate is 250 Hz with the 125 Hz filter selected. Therefore, when a conversion is complete (signaled by the DRDY flag), the next measurement will be ready.

When measurements on all three axes are completed, a logic high level is output to the DRDY pin, indicating “measurement data is ready.” The DRDY status can be monitored by the DRDY bit in Status Register (Address: \$09). The DRDY pin is kept high until one of the three Output Value Registers are read. If the next measurement data is written before the previous data is read, the DOVR bit in the Status Register will be set. Also note that in measurement mode, level detection mode and pulse detection mode are not available.

By default all three axes are enabled. X and/or Y and/or Z can be disabled. There is a choice between detecting an absolute signal or a positive or negative only signal on the enabled axes. There is also a choice between doing a detection for motion where X or Y or Z > Threshold vs. doing a detection for freefall where X & Y & Z < Threshold.

LEVEL DETECTION

When in Level or Pulse detection mode, it is not advisable to read the XYZ measurements because this can conflict with timing. The interrupts for level and pulse detection are at 600 Hz, while measurement mode is at 125 Hz. It is best to exit the pulse/level mode before taking a measurement on the XYZ.

Both the Level Detection and Pulse Detection modes can trigger an interrupt. Typically one interrupt is assigned to either pulse detection or level detection. To detect both at the same time 2 interrupts are required. The level detection mechanism has no timers associated with it. Once a set acceleration level is reached the interrupt pin will go high and remain high until the interrupt pin is cleared (See [Assigning, Clearing & Detecting Interrupts](#)).

By default all three axes are enabled and the detection range is 8g only. X and/or Y and/or Z can be disabled. There is a choice between detecting an Absolute signal or a Positive or Negative only signal on the enabled axes. There is also a choice between doing a detection for Motion where X or Y or Z > Threshold vs. doing a detection for Freefall where X & Y & Z < Threshold.

\$18: Control 1 (Read/Write) Setting the Detection Axes for X, Y and Z

This allows the user to define how many axes to use for detection. All axes are enabled by default. To disable write 1.

XDA: Disable X

YDA: Disable Y

ZDA: Disable Z

D7	D6	D5	D4	D3	D2	D1	D0	Reg \$18
DFBW	THOPT	ZDA	YDA	XDA	INTREG[1]	INTREG[0]	INTPIN	Function
0	0	0	0	0	0	0	0	Default

\$19: Control 2 (Read/Write) Motion Detection (OR Condition) or Freefall Detection (AND Condition)

LDPL = 0: Level detection polarity is positive and detecting condition is **OR** for all 3 axes.

X or Y or Z > Threshold

$||X||$ or $||Y||$ or $||Z||$ > Threshold

LDPL = 1: Level detection polarity is negative detecting condition is **AND** for all 3 axes.

X and Y and Z < Threshold

$||X||$ and $||Y||$ and $||Z||$ < Threshold

D7	D6	D5	D4	D3	D2	D1	D0	Reg \$19
--	--	--	--	--	DRVO	PDPL	LDPL	Function
0	0	0	0	0	0	0	0	Default

\$18: Control 1 (Read/Write): Setting the threshold to be an integer value or an absolute value

This allows the user to set the threshold to be absolute, or to be based on the threshold value as positive or negative.

THOPT = 0 Absolute; THOPT = 1 Positive Negative

D7	D6	D5	D4	D3	D2	D1	D0	Reg \$18
DFBW	THOPT	ZDA	YDA	XDA	INTREG[1]	INTREG[0]	INTPIN	Function
0	0	0	0	0	0	0	0	Default

\$1A: Level Detection Threshold Limit Value (Read/Write)

When an event is detected the interrupt pin (either INT1 or INT2) will go high. The interrupt pin assignment is set up in Register \$18, discussed in the [Assigning, Clearing & Detecting Interrupts](#) section. The detection status is monitored by the Detection Source Register \$0A.

D7	D6	D5	D4	D3	D2	D1	D0	Reg \$1A
LDTH[7]	LDTH[6]	LDTH[5]	LDTH[4]	LDTH[3]	LDTH[2]	LDTH[1]	LDTH[0]	Function
0	0	0	0	0	0	0	0	Default

LDTH[7:0]: Level detection threshold value. If THOPT bit in Detection Control Register is "0", it is unsigned 7 bits value and LDTH[7] should be "0". If THOPT bit is "1", it is signed 8 bits value.

THRESHOLD DETECTION FOR MOTION AND FREEFALL CONDITIONS

CASE 1: Motion Detection

Integer Value: $X > \text{Threshold}$ **OR** $Y > \text{Threshold}$ **OR** $Z > \text{Threshold}$

Reg \$18 THOPT=1; Reg 19 LDPL=0, Set Threshold to 3g, which is 47 counts (16 counts/g). Set register \$1A LDTH = \$2F.

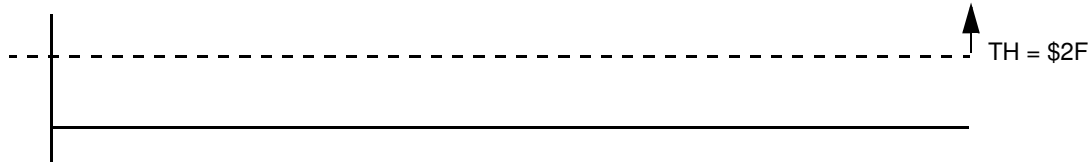

CASE 2: Motion Detection

Absolute: $||X|| > \text{Threshold}$ **OR** $||Y|| > \text{Threshold}$ **OR** $||Z|| > \text{Threshold}$

Reg \$18 THOPT=0; Reg 19 LDPL=0, Set Threshold to 3g, which is 47 counts (16 counts/g). Set register \$1A LDTH = \$2F.

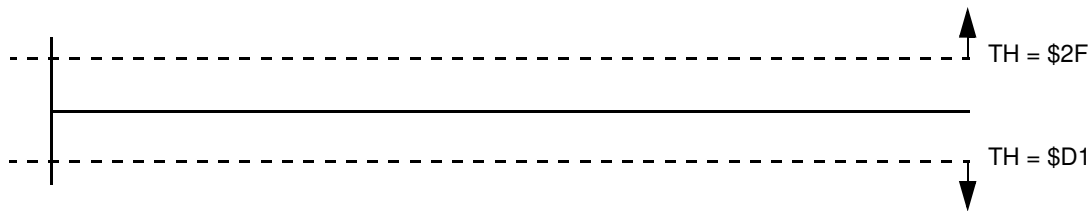

CASE 3: Freefall Detection

Integer Value: $X < \text{Threshold}$ **AND** $Y < \text{Threshold}$ **AND** $Z < \text{Threshold}$

Reg \$18 THOPT=1; Reg 19 LDPL=1, Set Threshold to 0.5g, which is 7 counts (16 counts/g). Set register \$1A LDTH = \$07

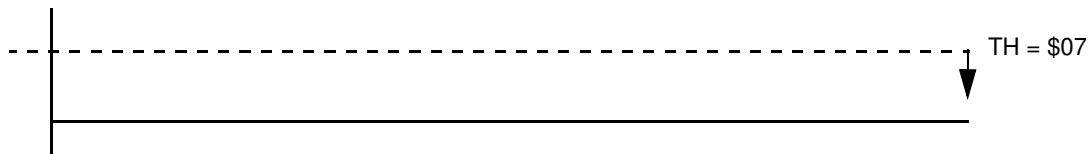

CASE 4: Freefall Detection

Absolute: $||X|| < \text{Threshold}$ **AND** $||Y|| < \text{Threshold}$ **AND** $||Z|| < \text{Threshold}$

Reg \$18 THOPT=0; Reg 19 LDPL=1, Set Threshold to +/-0.5g, which is 7 counts (16 counts/g). Set register \$1A LDTH = \$07.

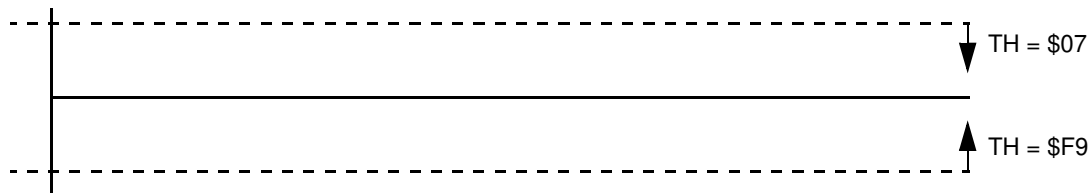

PULSE DETECTION

There are two interrupt pins available for detection of level and pulse conditions. The pulse detection has several timing windows associated with it. A single pulse and a double pulse can be detected. Also freefall can be detected. The interrupt pins can be assigned to detect the first pulse on one interrupt and the second pulse on the other interrupt. This is explained on [Page 15](#), under the [Assigning, Clearing & Detecting Interrupts](#) section.

By default all three axes are enabled and the detection range is 8g only. X and/or Y and/or Z can be disabled. There is a choice between doing a detection for Motion detection vs. doing a detection for Freefall.

\$18: Control 1 (Read/Write): Disable X, Y or Z for Pulse Detection

This allows the user to define how many axes to use for detection. All axes are enabled by default. To disable write 1

XDA: Disable X

YDA: Disable Y

ZDA: Disable Z.

D7	D6	D5	D4	D3	D2	D1	D0	Reg \$18
DFBW	THOPT	ZDA	YDA	XDA	INTREG[1]	INTREG[0]	INTPIN	Function
0	0	0	0	0	0	0	0	Default

\$19: Control 2 (Read/Write): Motion Detection (OR condition) or Freefall Detection (AND condition)

PDPL

0: Pulse detection polarity is positive and detecting condition is OR 3 axes.

1: Pulse detection polarity is negative and detecting condition is AND 3 axes.

D7	D6	D5	D4	D3	D2	D1	D0	Reg \$19
--	--	--	--	--	DRVO	PDPL	LDPL	Function
0	0	0	0	0	0	0	0	Default

CASE 1: Single Pulse Motion Detection: X or Y or Z > Pulse Threshold for Time < Pulse Duration

For motion detection with single pulse the device must be in pulse mode. PDPL in **Register \$19 = 0** for “OR” motion condition. The Pulse threshold must be set in **Register \$1B** and the pulse duration time window must also be set using **Register \$1C**. The pulse must be detected before the time window closes for the interrupt to trigger.

\$1B: Pulse Detection Threshold Limit Value (Read/Write)

D7	D6	D5	D4	D3	D2	D1	D0	Reg \$1B
PDTH[7]	PDTH[6]	PDTH[5]	PDTH[4]	PDTH[3]	PDTH[2]	PDTH[1]	PDTH[0]	Function
0	0	0	0	0	0	0	0	Default

\$1C: Pulse Duration Value (Read/Write)

D7	D6	D5	D4	D3	D2	D1	D0	Reg \$1C
PD[7]	PD[6]	PD[5]	PD[4]	PD[3]	PD[2]	PD[1]	PD[0]	Function
0	0	0	0	0	0	0	1	Default

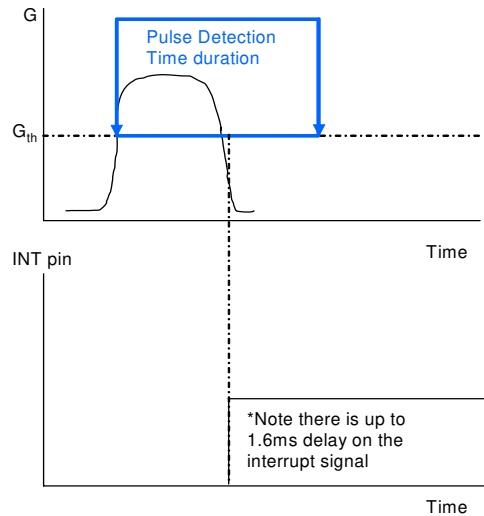

Single Pulse Detection (\$19 PDPL=0 indicating motion detection)
Time Window for 2nd pulse \$1E TW=0 indicating single pulse

Figure 4. Single Pulse Detection

CASE 2: Freefall Detection: X and Y and Z < Pulse Threshold for Time > Latency Time

For freefall detection, set in pulse mode. PDPL in **Register \$19** =1 for “AND” freefall condition. The Pulse threshold must be set in **Register \$1B** and the pulse latency time window must also be set using **Register \$1D**. All three axes must remain below the threshold longer than the time window for the interrupt to trigger.

\$1B: Pulse Detection Threshold Limit Value (Read/Write)

D7	D6	D5	D4	D3	D2	D1	D0	Reg \$1B
PDTH[7]	PDTH[6]	PDTH[5]	PDTH[4]	PDTH[3]	PDTH[2]	PDTH[1]	PDTH[0]	Function
0	0	0	0	0	0	0	0	Default

\$1D: Latency Time Value (Read/Write)

D7	D6	D5	D4	D3	D2	D1	D0	Reg \$1D
LT[7]	LT[6]	LT[5]	LT[4]	LT[3]	LT[2]	LT[1]	LT[0]	Function
0	0	0	0	0	0	0	1	Default

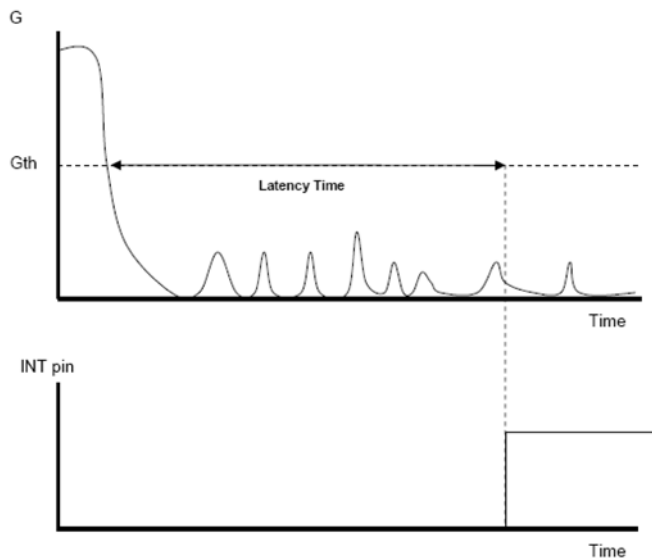

Negative Pulse Detection (DPOL = 1 & TW[7:0] = 0)
(Latency Time = 100 ms)

Detecting condition: “XOUT ≤ Threshold” and “YOUT ≤ Threshold” and “ZOUT ≤ Threshold”

Figure 5. Freefall Detection in Pulse Mode

CASE 3: Double Pulse Detection: X OR Y OR Z > Threshold for Pulse Duration1 < PTime1, Latency Time, AND X OR Y OR Z > Threshold for Pulse Duration2 < PTime2

For motion detection with double pulse the device must be in pulse mode. PDPL in **Register \$19 =0** for “OR” motion condition. The Pulse Threshold must be set in **Register \$1B** and the Pulse Duration Time Window must also be set using **Register \$1C**. Then the Latency Time (time between pulses) must be set in **Register \$1D** and then the Second Time Window must be set in **Register \$1E** for the time window of the second pulse. The pulse must be detected before the time window closes for the interrupt to trigger.

\$1B: Pulse Detection Threshold Limit Value (Read/Write)

D7	D6	D5	D4	D3	D2	D1	D0	Reg \$1B
PDTH[7]	PDTH[6]	PDTH[5]	PDTH[4]	PDTH[3]	PDTH[2]	PDTH[1]	PDTH[0]	Function
0	0	0	0	0	0	0	0	Default

\$1C: Pulse Duration Value (Read/Write)

D7	D6	D5	D4	D3	D2	D1	D0	Reg \$1C
PD[7]	PD[6]	PD[5]	PD[4]	PD[3]	PD[2]	PD[1]	PD[0]	Function
0	0	0	0	0	0	0	1	Default

\$1D: Latency Time Value (Read/Write)

D7	D6	D5	D4	D3	D2	D1	D0	Reg \$1D
LT[7]	LT[6]	LT[5]	LT[4]	LT[3]	LT[2]	LT[1]	LT[0]	Function
0	0	0	0	0	0	0	1	Default

\$1E: Time Window for 2nd Pulse Value (Read/Write)

D7	D6	D5	D4	D3	D2	D1	D0	Reg \$1E
TW[7]	TW[6]	TW[5]	TW[4]	TW[3]	TW[2]	TW[1]	TW[0]	Function
0	0	0	0	0	0	0	0	Default

When any of the events are detected, the interrupt pin (either INT1 or INT2) will go high. The interrupt pin assignment is set up in **Register \$18**, discussed in the [Assigning, Clearing & Detecting Interrupts](#) section on [Page 15](#). The detection status is monitored by the detection source register \$0A.

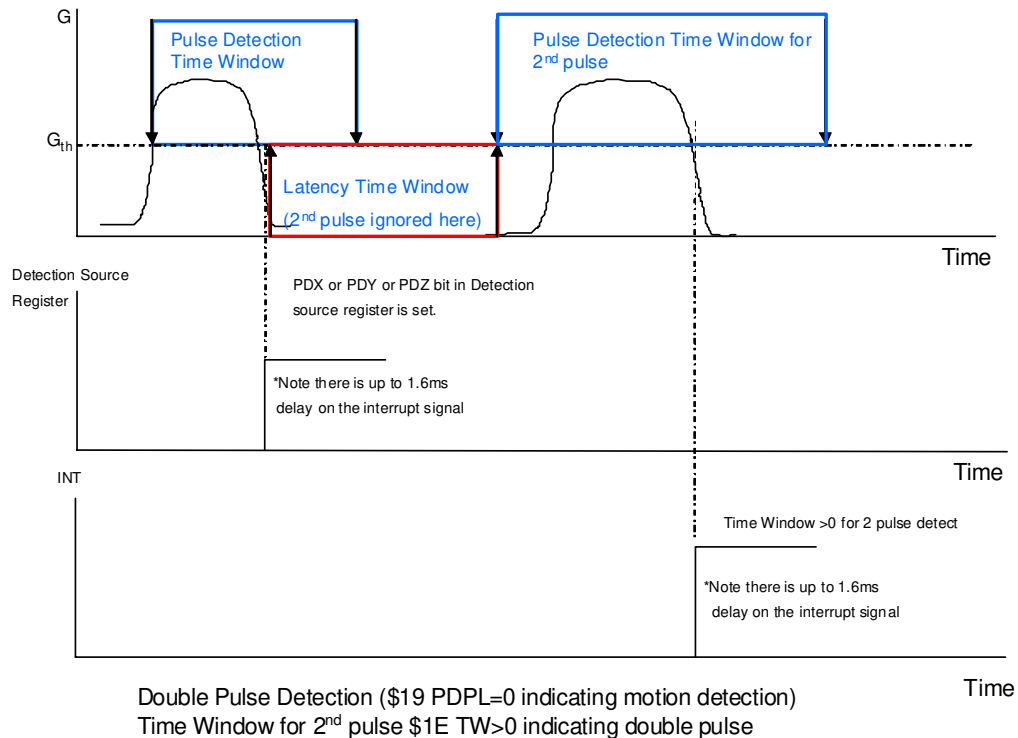

Figure 6. Double Pulse Detection

ASSIGNING, CLEARING & DETECTING INTERRUPTS

Assigning the interrupt pins is done in Register \$18. There are 3 combinations for the interrupt pins to be assigned which are outlined below in the table for INTREG[1:0].

\$18 Control 1 Register

D7	D6	D5	D4	D3	D2	D1	D0	Reg \$18
DFBW	THOPT	ZDA	YDA	XDA	INTREG[1]	INTREG[0]	INTPIN	Function
0	0	0	0	0	0	0	0	Default

Table 7. Configuring the Interrupt settings using Register \$18 with INTREG[1:0] bits

INTREG[1:0]	"INT1" Register Bit	"INT2" Register Bit
00	Level detection	Pulse Detection
01	Pulse Detection	Level Detection
10	Single Pulse detection	Single or Double Pulse Detection

00: INT1 Register is detecting Level while INT2 is detecting Pulse.

01: INT1 Register is detecting Pulse while INT2 is detecting Level.

10: INT1 Register is detecting a Single Pulse and INT2 is detecting Single Pulse (if 2nd Time Window = 0) or if there is a latency time window and second time window > 0 then INT2 will detect the double pulse only.

INTPIN: INT1 pin is routed to INT1 bit in Detection Source Register (\$0A) and INT2 pin is routed to INT2 bit in Detection Source Register (\$0A).

INTPIN: INT2 pin is routed to INT1 bit in Detection Source Register (\$0A) and INT1 pin is routed to INT2 bit in Detection Source Register (\$0A).

Note: When INTREG[1:0] = 10 for the condition to detect single pulse on INT1 and either single or double pulse on INT2, INT1 register bit can no longer be cleared by setting CLR_INT1 bit. It is cleared by setting CLR_INT2 bit. In this case, setting CLR_INT2 clears both INT1 and INT2 register bits and resets the detection operation. Follow the example given for clearing the interrupts.

Clearing the Interrupt Pins: Register \$17

\$17: Interrupt Latch Reset (Read/Write)

D7	D6	D5	D4	D3	D2	D1	D0	Reg \$17
--	--	--	--	--	--	CLR_INT2	CLR_INT1	Function
0	0	0	0	0	0	0	0	Default

CLR_INT1

1: Clear "INT1"

0: Do not clear "INT1"

CLR_INT2

1: Clear "INT2"

0: Do not clear "INT2"

After interrupt has triggered due to a detection, the interrupt pin (INT1 or INT2) need to be cleared by writing a logic 1. Then the interrupt pin should be enabled to trigger the next detection by setting it to a logic 0.

This example is to show how to reset the interrupt flags

```
void ClearIntLatch(void)
{
    IIC_ByteWrite(INTRST, 0x03);
    IIC_ByteWrite(INTRST, 0x00);
}
```

Detecting Interrupts

\$0A: Detection Source Register (Read only)

D7	D6	D5	D4	D3	D2	D1	D0	Reg \$0A
LDX	LDY	LDZ	PDX	PDY	PDZ	INT2	INT1	Function
0	0	0	0	0	0	0	0	Default

LDX

1: Level detection event is detected on X-axis
 0: Level detection event is not detected on X-axis

LDY

1: Level detection event is detected on Y-axis
 0: Level detection event is not detected on Y-axis

LDZ

1: Level detection event is detected on Z-axis
 0: Level detection event is not detected on Z-axis

PDX

1: 1st pulse is detected on X-axis
 0: 1st pulse is detected on X-axis

PDY

1: 1st pulse is detected on Y-axis
 0: 1st pulse is detected on Y-axis

PDZ

1: 1st pulse is detected on Z-axis
 0: 1st pulse is detected on Z-axis

INT1

1: Interrupt assigned by INTRG[1:0] bits in Control 1 Register (\$18) and is detected
 0: Interrupt assigned by INTRG[1:0] bits in Control 1 Register (\$18) and is not detected

INT2

1: Interrupt assigned by INTRG[1:0] bits in Control 1 Register (\$18) and is detected
 0: Interrupt assigned by INTRG[1:0] bits in Control 1 Register (\$18) and is not detected

DIGITAL INTERFACE

The MMA7456L has both an I²C and SPI digital output available for a communication interface. \overline{CS} pin is used for selecting the mode of communication. When \overline{CS} is low, SPI communication is selected. When \overline{CS} is high, I²C communication is selected.

Note: It is recommended to disable I²C during SPI communication to avoid communication errors between devices using a different SPI communication protocol. To disable I²C, set the I²C DIS bit in I²C Device Address register using SPI.

I²C Slave Interface

I²C is a synchronous serial communication between a master device and one or more slave devices. The master is typically a microcontroller, which provides the serial clock signal and addresses the slave device(s) on the bus. The MMA7456L communicates only in slave operation where the device address is \$1D. Multiple read and write modes are available. The protocol supports slave only operation. It does not support Hs mode, "10-bit addressing", "general call" and: "START byte".

SINGLE BYTE READ

The MMA7456L has an 10-bit ADC that can sample, convert and return sensor data on request. The transmission of an 8-bit command begins on the falling edge of SCL. After the eight clock cycles are used to send the command, note that the data returned is sent with the MSB first once the data is received. [Figure 7](#) shows the timing diagram for the accelerometer 8-bit I²C read operation. The Master (or MCU) transmits a start condition (ST) to the MMA7456L, slave address (\$1D), with the R/W bit set to "0" for a write, and the MMA7456L sends an acknowledgement. Then the Master (or MCU) transmits the 8-bit address of the register to read and the MMA7456L sends an acknowledgement. The Master (or MCU) transmits a repeated start condition (SR) and then addresses the MMA7456L (\$1D) with the R/W bit set to "1" for a read from the previously selected register. The Slave then acknowledges and transmits the data from the requested register. The Master does not acknowledge (NAK) it received the transmitted data, but transmits a stop condition to end the data transfer.

MULTIPLE BYTES READ

The MMA7456L automatically increments the received register address commands after a read command is received. Therefore, after following the steps of a single byte read, multiple bytes of data can be read from sequential registers after each MMA7456L acknowledgment (AK) is received until a NACK is received from the Master followed by a stop condition (SP) signalling an end of transmission. See [Figure 8](#).

SINGLE BYTE WRITE

To start a write command, the Master transmits a start condition (ST) to the MMA7456L, slave address (\$1D) with the R/W bit set to “0” for a write, the MMA7456L sends an acknowledgement. Then the Master (MCU) transmits the 8-bit address of the register to write to, and the MMA7456L sends an acknowledgement. Then the Master (or MCU) transmits the 8-bit data to write to the designated register and the MMA7456L sends an acknowledgement that it has received the data. Since this transmission is complete, the Master transmits a stop condition (SP) to the data transfer. The data sent to the MMA7456L is now stored in the appropriate register. See [Figure 9](#).

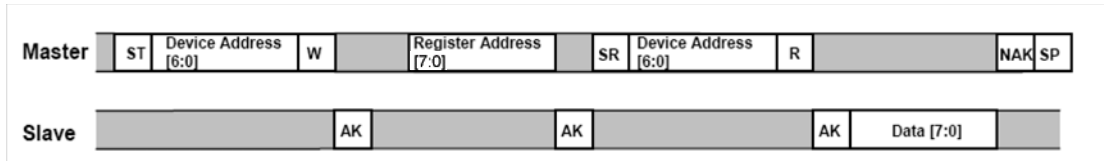

Figure 7. Single Byte Read - The Master is reading one address from the MMA7456L

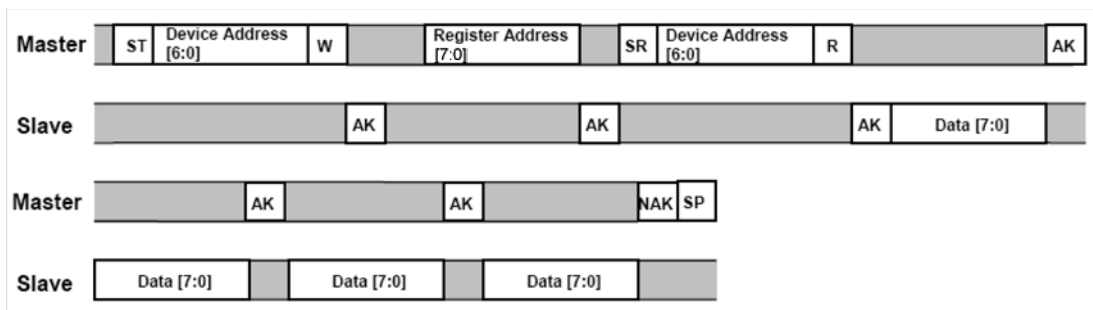

Figure 8. Multiple Bytes Read - The Master is reading multiple sequential registers from the MMA7456L

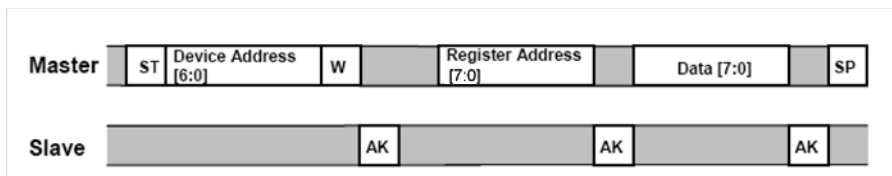

Figure 9. Single Byte Write - The Master (MCU) is writing to a single register of the MMA7456L

MULTIPLE BYTES WRITE

The MMA7456L automatically increments the received register address commands after a write command is received. Therefore, after following the steps of a single byte write, multiple bytes of data can be written to sequential registers after each MMA7456L acknowledgment (ACK) is received. See [Figure 10](#).

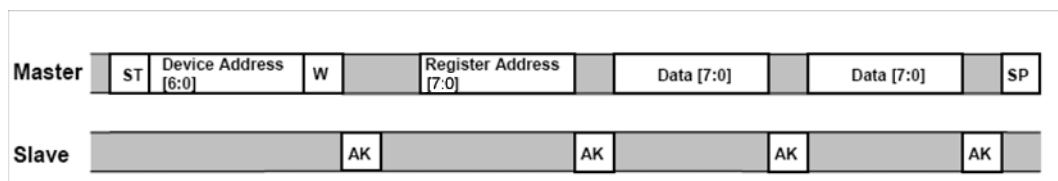

Figure 10. Multiple Byte Writes - The Master (MCU) is writing to multiple sequential registers of the MMA7456L

SPI Slave Interface

The MMA7456L also uses serial peripheral interface communication as a digital communication. The SPI communication is primarily used for synchronous serial communication between a master device and one or more slave devices. See [Figure 16](#) for an example of how to configure one master with one MMA745xL device. The MMA7456L is always operated as a slave device. Typically, the master device would be a microcontroller which would drive the clock (SPC) and chip select (\overline{CS}) signals.

The SPI interface consists of two control lines and two data lines: \overline{CS} , SPC, SDI, and SDO. The \overline{CS} , also known as Chip Select, is the slave device enable which is controlled by the SPI master. \overline{CS} is driven low at the start of a transmission. \overline{CS} is then driven high at the end of a transmission. SPC is the Serial Port Clock which is also controlled by the SPI master. SDI and SDO are the Serial Port Data Input and the Serial Port Data Output. The SDI and SDO data lines are driven at the falling edge of the SPC and should be captured at the rising edge of the SPC.

Read and write register commands are completed in 16 clock pulses or in multiples of 8, in the case of a multiple byte read/write.

SPI Read Operation

A SPI read transfer consists of a 1-bit Read/Write signal, a 6-bit address, and 1-bit don't care bit. (1-bit R/W=0 + 6-bits address + 1-bit don't care). The data to read is sent by the SPI interface during the next transfer. See [Figure 11](#) and [Figure 12](#) for the timing diagram for an 8-bit read in 4 wire and 3 wire modes, respectively.

SPI Write Operation

In order to write to one of the 8-bit registers, an 8-bit write command must be sent to the MMA7456L. The write command consists of an MSB (0=read, 1=write) to indicate writing to the MMA7456L register, followed by a 6-bit address and 1 don't care bit.

The command should then be followed the 8-bit data transfer. See [Figure 13](#) for the timing diagram for an 8-bit data write.

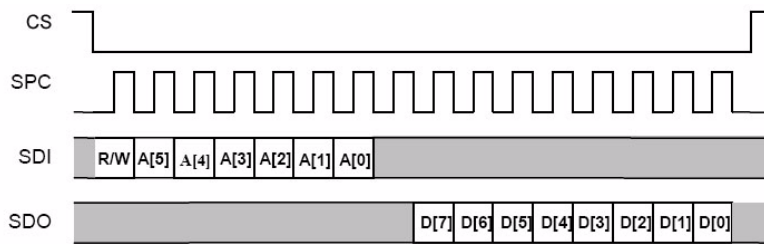

Figure 11. SPI Timing Diagram for 8-Bit Register Read (4 Wire Mode)

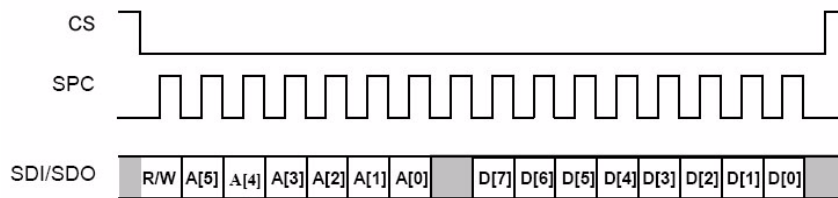

Figure 12. SPI Timing Diagram for 8-Bit Register Read (3 Wire Mode)

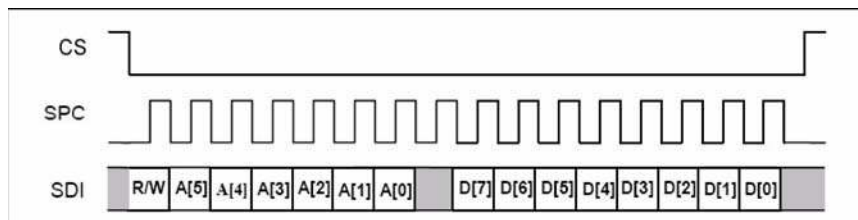

Figure 13. SPI Timing Diagram for 8-Bit Register Write (3 Wire Mode)

BASIC CONNECTIONS

Pin Descriptions

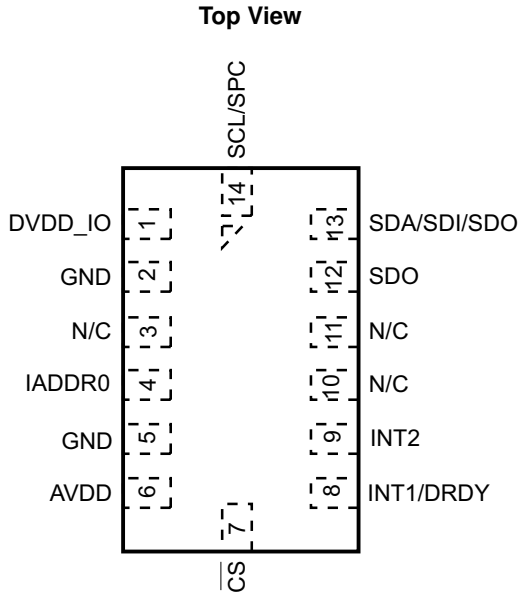

Figure 14. Pinout Description

Table 8. Pin Descriptions

Pin #	Pin Name	Description	Pin Status
1	DVDD_IO	Digital Power for I/O pads	Input
2	GND	Ground	Input
3	N/C	No internal connection. Leave unconnected or connect to Ground.	Input
4	IADDR0	I ² C Address Bit 0	Input
5	GND	Ground	Input
6	AVDD	Analog Power	Input
7	\overline{CS}	SPI Enable (0), I ² C Enable (1)	Input
8	INT1/DRDY	Interrupt 1/ Data Ready	Output
9	INT2	Interrupt 2	Output
10	N/C	No internal connection. Leave unconnected or connect to Ground.	Input
11	N/C	No internal connection. Leave unconnected or connect to Ground.	Input
12	SDO	SPI Serial Data Output	Output
13	SDA/SDI/SDO	I ² C Serial Data (SDA), SPI Serial Data Input (SDI), 3-wire interface Serial Data Output (SDO)	Open Drain/ Input/ Output
14	SCL/SPC	I ² C Serial Clock (SCL), SPI Serial Clock (SPC)	Input

Recommended PCB Layout for Interfacing Accelerometer to Microcontroller

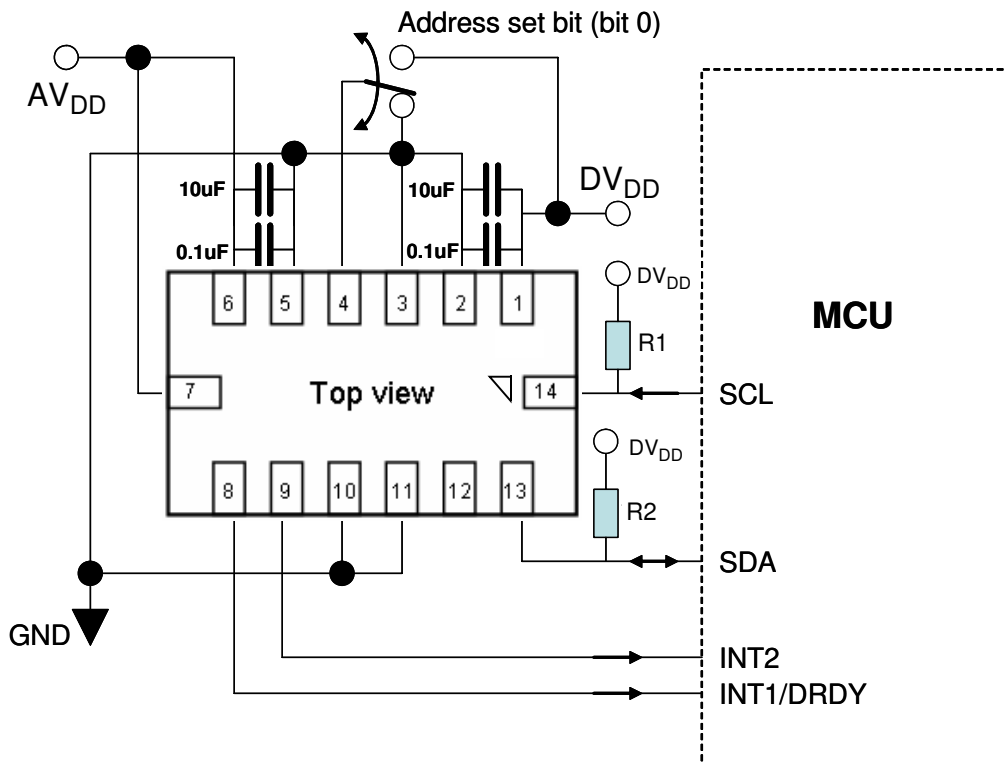

Figure 15. I²C Connection to MCU

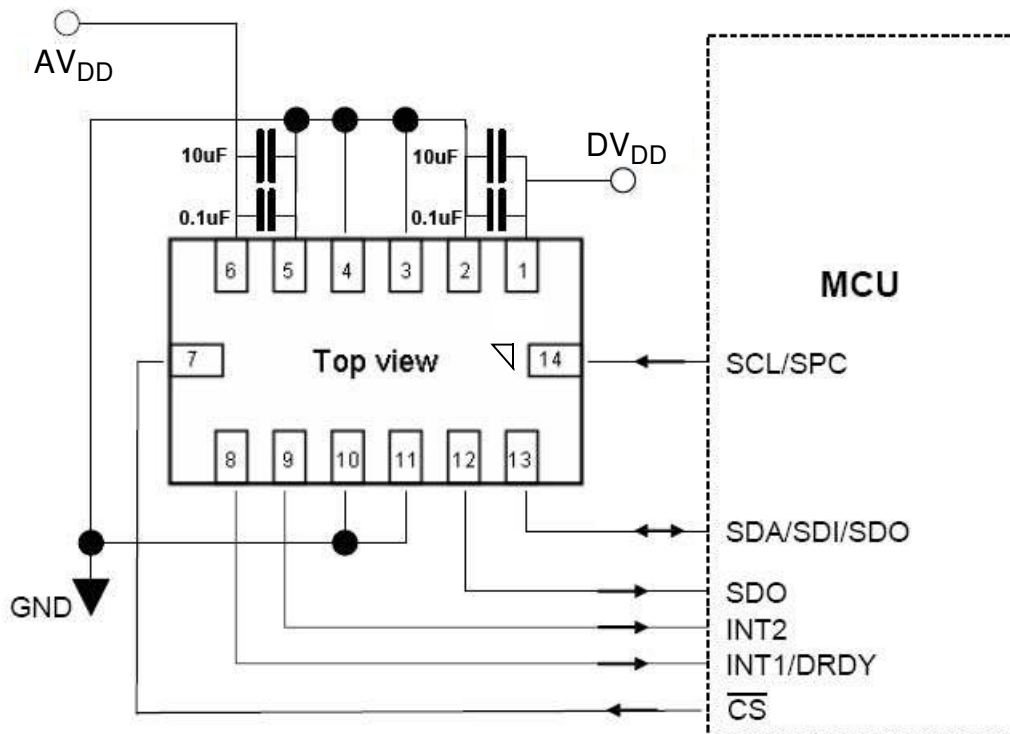

Figure 16. SPI Connection to MCU

NOTES:

1. Use a 0.1 μ F and a 10 μ F capacitor on AV_{DD} to and DV_{DD} to decouple the power source.
2. Physical coupling distance of the accelerometer to the microcontroller should be minimal.
3. PCB layout of power and ground should not couple power supply noise.
4. Accelerometer and microcontroller should not be a high current path.
5. Any external power supply switching frequency should be selected such that they do not interfere with the internal accelerometer sampling frequency (sampling frequency). This will prevent aliasing errors.
6. Physical distance of the two GND pins (Pin 2 and Pin 5) tied together should be at the shortest distance.

Table 9. User Register Summary

Address	Name	Definition	Bit 7	Bit 6	Bit 5	Bit 4	Bit 3	Bit 2	Bit 1	Bit 0
\$00	XOUTL	10 bits output value X LSB	XOUT[7]	XOUT[6]	XOUT[5]	XOUT[4]	XOUT[3]	XOUT[2]	XOUT[1]	XOUT[0]
\$01	XOUTH	10 bits output value X MSB	--	--	--	--	--	--	XOUT[9]	XOUT[8]
\$02	YOUTL	10 bits output value Y LSB	YOUT[7]	YOUT[6]	YOUT[5]	YOUT[4]	YOUT[3]	YOUT[2]	YOUT[1]	YOUT[0]
\$03	YOUTH	10 bits output value Y MSB	--	--	--	--	--	--	YOUT[9]	YOUT[8]
\$04	ZOUTL	10 bits output value Z LSB	ZOUT[7]	ZOUT[6]	ZOUT[5]	ZOUT[4]	ZOUT[3]	ZOUT[2]	ZOUT[1]	ZOUT[0]
\$05	ZOUTH	10 bits output value Z MSB	--	--	--	--	--	--	ZOUT[9]	ZOUT[8]
\$06	XOUT8	8 bits output value X	XOUT[7]	XOUT[6]	XOUT[5]	XOUT[4]	XOUT[3]	XOUT[2]	XOUT[1]	XOUT[0]
\$07	YOUT8	8 bits output value Y	YOUT[7]	YOUT[6]	YOUT[5]	YOUT[4]	YOUT[3]	YOUT[2]	YOUT[1]	YOUT[0]
\$08	ZOUT8	8 bits output value Z	ZOUT[7]	ZOUT[6]	ZOUT[5]	ZOUT[4]	ZOUT[3]	ZOUT[2]	ZOUT[1]	ZOUT[0]
\$09	STATUS	Status registers	--	--	--	--	--	PERR	DOVR	DRDY
\$0A	DETSRC	Detection source registers	LDX	LDY	LDZ	PDX	PDY	PDZ	INT2	INT1
\$0B	TOUT	"Temperature output value" (Optional)	TMP[7]	TMP[6]	TMP[5]	TMP[4]	TMP[3]	TMP[2]	TMP[1]	TMP[0]
\$0C		(Reserved)	--	--	--	--	--	--	--	--
\$0D	I2CAD	I ² C device address	I2CDIS	DAD[6]	DAD[5]	DAD[4]	DAD[3]	DAD[2]	DAD[1]	DAD[0]
\$0E	USRINF	User information (Optional)	UI[7]	UI[6]	UI[5]	UI[4]	UI[3]	UI[2]	UI[1]	UI[0]
\$0F	WHOAMI	"Who am I" value (Optional)	ID[7]	ID[6]	ID[5]	ID[4]	ID[3]	ID[2]	ID[1]	ID[0]
\$10	XOFFL	Offset drift X value (LSB)	XOFF[7]	XOFF[6]	XOFF[5]	XOFF[4]	XOFF[3]	XOFF[2]	XOFF[1]	XOFF[0]
\$11	XOFFH	Offset drift X value (MSB)	--	--	--	--	--	XOFF[10]	XOFF[9]	XOFF[8]
\$12	YOFFL	Offset drift Y value (LSB)	YOFF[7]	YOFF[6]	YOFF[5]	YOFF[4]	YOFF[3]	YOFF[2]	YOFF[1]	YOFF[0]
\$13	YOFFH	Offset drift Y value (MSB)	--	--	--	--	--	YOFF[10]	YOFF[9]	YOFF[8]
\$14	ZOFFL	Offset drift Z value (LSB)	ZOFF[7]	ZOFF[6]	ZOFF[5]	ZOFF[4]	ZOFF[3]	ZOFF[2]	ZOFF[1]	ZOFF[0]
\$15	ZOFFH	Offset drift Z value (MSB)	--	--	--	--	--	ZOFF[10]	ZOFF[9]	ZOFF[8]
\$16	MCTL	Mode control	--	DRPD	SPI3W	STON	GLVL[1]	GLVL[0]	MOD[1]	MOD[0]
\$17	INTRST	Interrupt latch reset	--	--	--	--	--	--	CLRINT2	CLRINT1
\$18	CTL1	Control 1	DFBW	THOPT	ZDA	YDA	XDA	INTRG[1]	INTRG[0]	INTPIN
\$19	CTL2	Control 2	--	--	--	--	--	DRVO	PDPL	LDPL
\$1A	LDTH	Level detection threshold limit value	LDTH[7]	LDTH[6]	LDTH[5]	LDTH[4]	LDTH[3]	LDTH[2]	LDTH[1]	LDTH[0]
\$1B	PDTH	Pulse detection threshold limit value	PDTH[7]	PDTH[6]	PDTH[5]	PDTH[4]	PDTH[3]	PDTH[2]	PDTH[1]	PDTH[0]
\$1C	PW	Pulse duration value	PD[7]	PD[6]	PD[5]	PD[4]	PD[3]	PD[2]	PD[1]	PD[0]
\$1D	LT	Latency time value	LT[7]	LT[6]	LT[5]	LT[4]	LT[3]	LT[2]	LT[1]	LT[0]
\$1E	TW	Time window for 2 nd pulse value	TW[7]	TW[6]	TW[5]	TW[4]	TW[3]	TW[2]	TW[1]	TW[0]
\$1F		(Reserved)	--	--	--	--	--	--	--	--

REGISTER DEFINITIONS

\$00: 10bits Output Value X LSB (Read only)

D7	D6	D5	D4	D3	D2	D1	D0	Bit
XOUT [7]	XOUT [6]	XOUT [5]	XOUT [4]	XOUT [3]	XOUT [2]	XOUT [1]	XOUT[0]	Function
0	0	0	0	0	0	0	0	Default

Signed byte data (2's complement): 0g = 10'h000

Reading low byte XOUTL latches high byte XOUTH to allow 10-bit reads.

XOUTH should be read directly following XOUTL read.

\$01: 10bits Output Value X MSB (Read only)

D7	D6	D5	D4	D3	D2	D1	D0	Bit
--	--	--	--	--	--	XOUT [9]	XOUT[8]	Function
0	0	0	0	0	0	0	0	Default

Signed byte data (2's complement): 0g = 10'h000

Reading low byte XOUTL latches high byte XOUTH to allow 10-bit reads.

XOUTH should be read directly following XOUTL read.

\$02: 10bits Output Value Y LSB (Read only)

D7	D6	D5	D4	D3	D2	D1	D0	Bit
YOUT [7]	YOUT [6]	YOUT [5]	YOUT [4]	YOUT [3]	YOUT [2]	YOUT [1]	YOUT[0]	Function
0	0	0	0	0	0	0	0	Default

Signed byte data (2's complement): 0g = 10'h000

Reading low byte YOUTL latches high byte YOUTH to allow coherent 10-bit reads.

YOUTH should be read directly following YOUTL.

\$03: 10bits Output Value Y MSB (Read only)

D7	D6	D5	D4	D3	D2	D1	D0	Bit
--	--	--	--	--	--	YOUT [9]	YOUT[8]	Function
0	0	0	0	0	0	0	0	Default

Signed byte data (2's complement): 0g = 10'h000

Reading low byte ZOUTL latches high byte ZOUTH to allow coherent 10-bit reads.

ZOUTH should be read directly following ZOUTL.

\$04: 10bits Output Value Z LSB (Read only)

D7	D6	D5	D4	D3	D2	D1	D0	Bit
ZOUT [7]	ZOUT [6]	ZOUT [5]	ZOUT [4]	ZOUT [3]	ZOUT [2]	ZOUT [1]	ZOUT[0]	Function
0	0	0	0	0	0	0	0	Default

Signed byte data (2's complement): 0g = 10'h000

Reading low byte ZOUTL latches high byte ZOUTH to allow coherent 10-bit reads.

ZOUTH should be read directly following ZOUTL.

\$05: 10bits Output Value X MSB (Read only)

D7	D6	D5	D4	D3	D2	D1	D0	Bit
--	--	--	--	--	--	ZOUT [9]	ZOUT[8]	Function
0	0	0	0	0	0	0	0	Default

\$06: 8bits Output Value X (Read only)

D7	D6	D5	D4	D3	D2	D1	D0	Bit
XOUT[7]	XOUT [6]	XOUT [5]	XOUT [4]	XOUT [3]	XOUT [2]	XOUT [1]	XOUT [0]	Function
0	0	0	0	0	0	0	0	Default

Signed byte data (2's complement): 0g = 8'h00

\$07: 8bits Output Value Y (Read only)

D7	D6	D5	D4	D3	D2	D1	D0	Bit
YOUT[7]	YOUT [6]	YOUT [5]	YOUT [4]	YOUT [3]	YOUT [2]	YOUT [1]	YOUT [0]	Function
0	0	0	0	0	0	0	0	Default

Signed byte data (2's complement): 0g = 8'h00

\$08: 8bits Output Value Z (Read only)

D7	D6	D5	D4	D3	D2	D1	D0	Bit
ZOUT[7]	ZOUT [6]	ZOUT [5]	ZOUT [4]	ZOUT [3]	ZOUT [2]	ZOUT [1]	ZOUT [0]	Function
0	0	0	0	0	0	0	0	Default

Signed byte data (2's complement): 0g = 8'h00

\$09: Status Register (Read only)

D7	D6	D5	D4	D3	D2	D1	D0	Bit
--	--	--	--	--	PERR	DOVR	DRDY	Function
0	0	0	0	0	0	0	0	Default

DRDY

1: Data is ready
0: Data is not ready

DOVR

1: Data is over written
0: Data is not over written

PERR

1: Parity error is detected in trim data. Then, self-test is disabled
0: Parity error is not detected in trim data

\$0A: Detection Source Register (Read only)

D7	D6	D5	D4	D3	D2	D1	D0	Bit
LDX	LDY	LDZ	PDX	PDY	PDZ	INT2	INT1	Function
0	0	0	0	0	0	0	0	Default

LDX

1: Level detection detected on X-axis
0: Level detection not detected on X-axis

LDY

1: Level detection detected on Y-axis
0: Level detection not detected on Y-axis

LDZ

1: Level detection detected on Z-axis
0: Level detection not detected on Z-axis

PDX *Note

1: Pulse is detected on X-axis at single pulse detection
0: Pulse is not detected on X-axis at single pulse detection

PDY *Note

1: Pulse is detected on Y-axis at single pulse detection
0: Pulse is not detected on Y-axis at single pulse detection

PDZ *Note

1: Pulse is detected on Z-axis at single pulse detection
0: Pulse is not detected on Z-axis at single pulse detection
Note: This bit value is not valid at double pulse detection

INT1

1: Interrupt assigned by INTRG[1:0] bits in Control 1 Register (\$18) and is detected
0: Interrupt assigned by INTRG[1:0] bits in Control 1 Register (\$18) and is not detected

INT2

1: Interrupt assigned by INTRG[1:0] bits in Control 1 Register (\$18) and is detected
0: Interrupt assigned by INTRG[1:0] bits in Control 1 Register (\$18) and is not detected

***Note:** Must define DRDY to be an output to either INT1 or not. This is done through bit DRPD located in Register \$16.

\$0D: I²C Device Address (Bit 6-0: Read only, Bit 7: Read/Write)

D7	D6	D5	D4	D3	D2	D1	D0	Bit
I2CDIS	DVAD[6]	DVAD[5]	DVAD[4]	DVAD[3]	DVAD[2]	DVAD[1]	DVAD[0]	Function
0	0	0	1	1	1	0	1	Default

I2CDIS

0: I²C and SPI are available.
1: I²C is disabled.

DVAD[6:0]: I²C device address

\$0E: User Information (Read Only: Optional)

D7	D6	D5	D4	D3	D2	D1	D0	Bit
UI[7]	UI[6]	UI[5]	UI[4]	UI[3]	UI[2]	UI[1]	UI[0]	Function
0/OTP	0/OTP	0/OTP	0/OTP	0/OTP	0/OTP	0/OTP	0/OTP	Default

UI2[7:0]: User information

\$0F: “Who Am I” Value (Read only: Optional)

D7	D6	D5	D4	D3	D2	D1	D0	Bit
ID[7]	ID [6]	ID [5]	ID [4]	ID [3]	ID [2]	ID [1]	ID [0]	Function
0/OTP	0/OTP	0/OTP	0/OTP	0/OTP	0/OTP	0/OTP	0/OTP	Default

\$10: Offset Drift X LSB (Read/Write)

The following Offset Drift Registers are used for setting and storing the offset calibrations to eliminate the 0g offset. Please refer to Freescale application note AN3745 for detailed instructions on the process to set and store the calibration values.

D7	D6	D5	D4	D3	D2	D1	D0	Bit
XOFF[7]	XOFF [6]	XOFF [5]	XOFF [4]	XOFF [3]	XOFF [2]	XOFF [1]	XOFF [0]	Function
0	0	0	0	0	0	0	0	Default

Signed byte data (2’s complement): User level offset trim value for X-axis

Bit	XOFF[7]	XOFF[6]	XOFF[5]	XOFF[4]	XOFF[3]	XOFF[2]	XOFF[1]	XOFF[0]
Weight*	64 LSB	32 LSB	16 LSB	8 LSB	4 LSB	2 LSB	1 LSB	0.5 LSB

*Bit weight is for 8g 10bit data output. Typical value for reference only. Variation is specified in “Electrical Characteristics” section.

\$11: Offset Drift X MSB (Read/Write)

D7	D6	D5	D4	D3	D2	D1	D0	Bit
--	--	--	--	--	XOFF [10]	XOFF [9]	XOFF [8]	Function
0	0	0	0	0	0	0	0	Default

Signed byte data (2’s complement): User level offset trim value for X-axis

\$12: Offset Drift Y LSB (Read/Write)

D7	D6	D5	D4	D3	D2	D1	D0	Bit
YOFF[7]	YOFF [6]	YOFF [5]	YOFF [4]	YOFF [3]	YOFF [2]	YOFF [1]	YOFF [0]	Function
0	0	0	0	0	0	0	0	Default

Signed byte data (2’s complement): User level offset trim value for Y-axis

Bit	YOFF[7]	YOFF[6]	YOFF[5]	YOFF[4]	YOFF[3]	YOFF[2]	YOFF[1]	YOFF[0]
Weight*	64 LSB	32 LSB	16 LSB	8 LSB	4 LSB	2 LSB	1 LSB	0.5 LSB

*Bit weight is for 2g 8bit data output. Typical value for reference only. Variation is specified in “Electrical Characteristics” section.

\$13: Offset Drift Y MSB (Read/Write)

D7	D6	D5	D4	D3	D2	D1	D0	Bit
--	--	--	--	--	YOFF [10]	YOFF [9]	YOFF [8]	Function
0	0	0	0	0	0	0	0	Default

Signed byte data (2’s complement): User level offset trim value for Y-axis

Bit	YOFF[10]	YOFF[9]	YOFF[8]
Weight*	Polarity	256 LSB	128 LSB

*Bit weight is for 2g 8bit data output. Typical value for reference only. Variation is specified in “Electrical Characteristics” section.

\$14: Offset Drift Z LSB (Read/Write)

D7	D6	D5	D4	D3	D2	D1	D0	Bit
ZOFF[7]	ZOFF[6]	ZOFF[5]	ZOFF[4]	ZOFF[3]	ZOFF[2]	ZOFF[1]	ZOFF[0]	Function
0	0	0	0	0	0	0	0	Default

Signed byte data (2’s complement): User level offset trim value for Z-axis

Bit	ZOFF[7]	ZOFF[6]	ZOFF[5]	ZOFF[4]	ZOFF[3]	ZOFF[2]	ZOFF[1]	ZOFF[0]
Weight*	64 LSB	32 LSB	16 LSB	8 LSB	4 LSB	2 LSB	1 LSB	0.5 LSB

*Bit weight is for 2g 8bit data output. Typical value for reference only. Variation is specified in “Electrical Characteristics” section.

\$15: Offset Drift Z MSB (Read/Write)

D7	D6	D5	D4	D3	D2	D1	D0	Bit
--	--	--	--	--	ZOFF[10]	ZOFF[9]	ZOFF[8]	Function
0	0	0	0	0	0	0	0	Default

Signed byte data (2's complement): User level offset trim value for Z-axis

Bit	ZOFF[10]	ZOFF[9]	ZOFF[8]
Weight*	Polarity	256 LSB	128 LSB

*Bit weight is for 2g 8bit data output. Typical value for reference only. Variation is specified in "Electrical Characteristics" section.

\$16: Mode Control Register (Read/Write)

D7	D6	D5	D4	D3	D2	D1	D0	Bit
--	DRPD	SPI3W	STON	GLVL[1]	GLVL[0]	MODE[1]	MODE[0]	Function
0	0	0	0	0	0	0	0	Default

Table 10. Configuring the g-Select for 8-bit output using Register \$16 with GLVL[1:0] bits

GLVL [1:0]	g-Range	Sensitivity
00	8g	16 LSB/g
01	2g	64 LSB/g
10	4g	32 LSB/g

GLVL [1:0]

00: 8g is selected for measurement range.

10: 4g is selected for measurement range.

01: 2g is selected for measurement range.

MODE [1:0]

00: Standby Mode

01: Measurement Mode

10: Level Detection Mode

11: Pulse Detection Mode

STON

0: Self-test is not enabled

1: Self-test is enabled

SPI3W

0: SPI is 4 wire mode

1: SPI is 3 wire mode

DRPD

0: Data ready status is output to INT1/DRDY PIN

1: Data ready status is not output to INT1/DRDY PIN

Table 11. Configuring the Mode using Register \$16 with MODE[1:0] bits

MODE [1:0]	Function
00	Standby Mode
01	Measurement Mode
10	Level Detection Mode
11	Pulse Detection Mode

\$17: Interrupt Latch Reset (Read/Write)

D7	D6	D5	D4	D3	D2	D1	D0	Bit
--	--	--	--	--	--	CLR_INT2	CLR_INT1	Function
0	0	0	0	0	0	0	0	Default

CLR_INT1

1: Clear "INT1" and LDX/LDY/LDZ or PDX/PDY/PDZ bits in **Detection Source Register (\$0A)** depending on **Control1(\$18) INTREG[1:0]** setting.

0: Do not clear "INT1" LDX/LDY/LDZ or PDX/PDY/PDZ bits in **Detection Source Register (\$0A)**

CLR_INT2

1: Clear "INT2" and LDX/LDY/LDZ or PDX/PDY/PDZ bits in **Detection Source Register (\$0A)** depending on **Control1(\$18) INTREG[1:0]** setting.

0: Do not clear "INT2" and LDX/LDY/LDZ or PDX/PDY/PDZ bits in **Detection Source Register (\$0A)**.

\$18 Control 1 (Read/Write)

D7	D6	D5	D4	D3	D2	D1	D0	Bit
DFBW	THOPT	ZDA	YDA	XDA	INTREG[1]	INTREG[0]	INTPIN	Function
0	0	0	0	0	0	0	0	Default

Table 12. Configuring the Interrupt settings using Register \$18 with INTREG[1:0] bits

INTREG[1:0]	"INT1" Register Bit	"INT2" Register Bit
00	Level detection	Pulse Detection
01	Pulse Detection	Level Detection
10	Single Pulse detection	Single or Double Pulse Detection

00: INT1 Register is detecting Level while INT2 is detecting Pulse.

01: INT1 Register is detecting Pulse while INT2 is detecting Level.

10: INT1 Register is detecting a Single Pulse and INT2 is detecting Single Pulse (if 2nd Time Window = 0) or if there is a latency time window and second time window > 0 then INT2 will detect the double pulse only.

INTPIN: INT1 pin is routed to INT1 bit in Detection Source Register (\$0A) and INT2 pin is routed to INT2 bit in Detection Source Register (\$0A).

INTPIN: INT2 pin is routed to INT1 bit in Detection Source Register (\$0A) and INT1 pin is routed to INT2 bit in Detection Source Register (\$0A).

Note: When INTREG[1:0] = 10 for the condition to detect single pulse on INT1 and either single or double pulse on INT2, INT1 register bit can no longer be cleared by setting CLR_INT1 bit. It is cleared by setting CLR_INT2 bit. In this case, setting CLR_INT2 clears both INT1 and INT2 register bits and resets the detection operation.

XDA

1: X-axis is disabled for detection.

0: X-axis is enabled for detection.

YDA

1: Y-axis is disabled for detection.

0: Y-axis is enabled for detection.

ZDA

1: Z-axis is disabled for detection.

0: Z-axis is enabled for detection.

THOPT (This bit is valid for level detection only, not valid for pulse detection)

0: Threshold value is absolute only

1: Integer value is available.

DFBW

0: Digital filter band width is 62.5 Hz

1: Digital filter band width is 125 Hz

\$19: Control 2 (Read/Write)

D7	D6	D5	D4	D3	D2	D1	D0	Bit
					DRVO	PDPL	LDPL	Function
0	0	0	0	0	0	0	0	Default

LDPL

0: Level detection polarity is positive and detecting condition is OR 3 axes.

1: Level detection polarity is negative detecting condition is AND 3 axes.

PDPL

0: Pulse detection polarity is positive and detecting condition is OR 3 axes.

1: Pulse detection polarity is negative and detecting condition is AND 3 axes.

DRVO

0: Standard drive strength on SDA/SDO pin

1: Strong drive strength on SDA/SDO pin

\$1A: Level Detection Threshold Limit Value (Read/Write)

D7	D6	D5	D4	D3	D2	D1	D0	Bit
LDTH[7]	LDTH[6]	LDTH[5]	LDTH[4]	LDTH[3]	LDTH[2]	LDTH[1]	LDTH[0]	Function
0	0	0	0	0	0	0	0	Default

LDTH[7:0]: Level detection threshold value. If THOPT bit in Detection Control Register is “0”, it is unsigned 7 bits value and LDTH[7] should be “0”. If THOPT bit is “1”, it is signed 8 bits value.

\$1B: Pulse Detection Threshold Limit Value (Read/Write)

D7	D6	D5	D4	D3	D2	D1	D0	Bit
XPDTH	PDTH[6]	PDTH[5]	PDTH[4]	PDTH[3]	PDTH[2]	PDTH[1]	PDTH[0]	Function
0	0	0	0	0	0	0	0	Default

PDTH[6:0]: Pulse detection threshold value (unsigned 7 bits).

XPDTH: This bit should be “0”.

\$1C: Pulse Duration Value (Read/Write)

D7	D6	D5	D4	D3	D2	D1	D0	Bit
PD[7]	PD[6]	PD[5]	PD[4]	PD[3]	PD[2]	PD[1]	PD[0]	Function
0	0	0	0	0	0	0	0	Default

Min: PD[7:0] = 4'h01 = 0.5 ms

Max: PD[7:0] = 4'hFF = 127 ms

1 LSB = 0.5 ms

\$1D: Latency Time Value (Read/Write)

D7	D6	D5	D4	D3	D2	D1	D0	Bit
LT[7]	LT[6]	LT[5]	LT[4]	LT[3]	LT[2]	LT[1]	LT[0]	Function
0	0	0	0	0	0	0	0	Default

Min: LT[7:0] = 8'h01 = 1 ms

Max: LT[7:0] = 8'hFF = 255 ms

1 LSB = 1 ms

\$1E: Time Window for 2nd Pulse Value (Read/Write)

D7	D6	D5	D4	D3	D2	D1	D0	Bit
TW[7]	TW[6]	TW[5]	TW[4]	TW[3]	TW[2]	TW[1]	TW[0]	Function
0	0	0	0	0	0	0	0	Default

Min: TW[7:0] = 8'h01 = 1 ms (Single pulse detection)

Max: TW[7:0] = 8'hFF = 255 ms

1 LSB = 1 ms

SENSING DIRECTION AND OUTPUT RESPONSE

The following figure shows sensing direction and the output response for 2g mode.

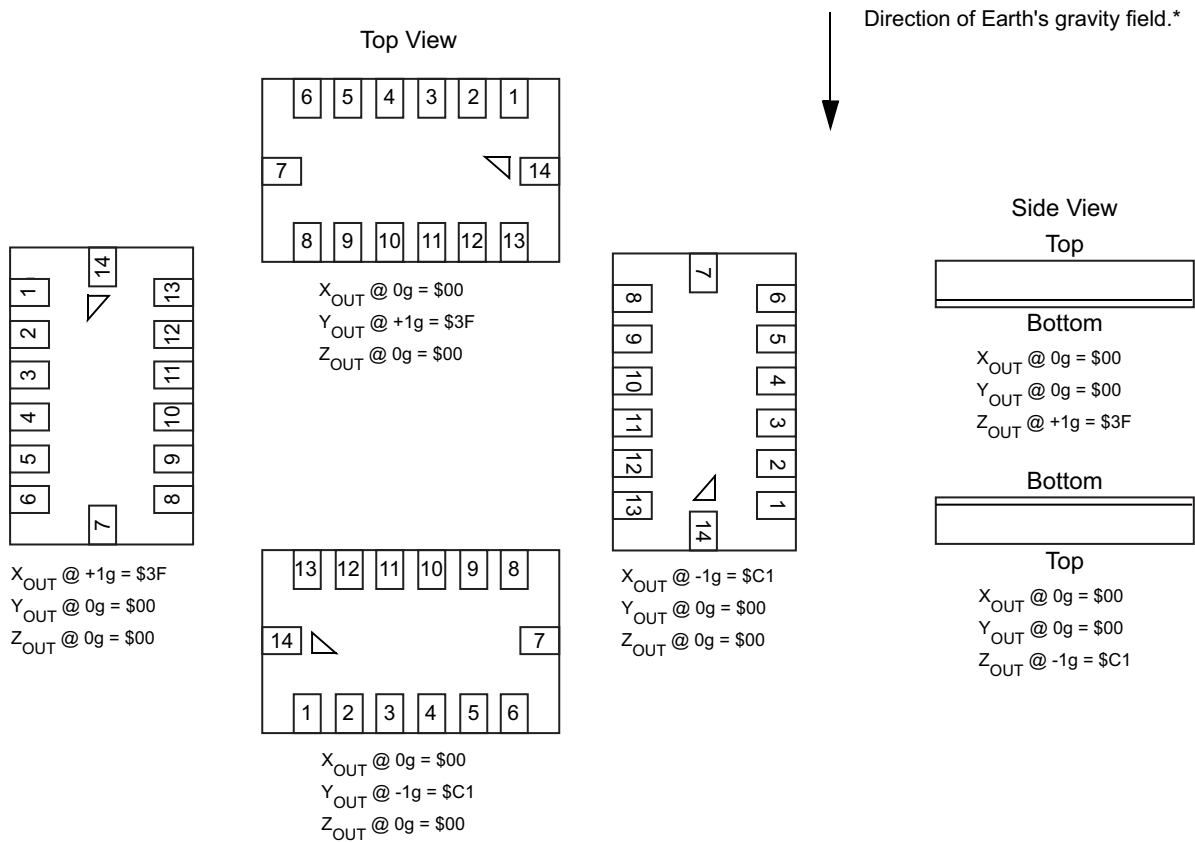

* When positioned as shown, the Earth's gravity will result in a positive 1g output.

Figure 17. Sensing Direction and Output Response at 2g Mode

Table 13. Acceleration vs. Output (8-bit data)

FS Mode	Acceleration	Output
2g Mode	-2g	\$80
	-1g	\$C1
	0g	\$00
	+1g	\$3F
	+2g	\$7F
4g Mode	-4g	\$80
	-1g	\$E1
	0g	\$00
	+1g	\$1F
	+4g	\$7F
8g Mode	-8g	\$80
	-1g	\$F1
	0g	\$00
	+1g	\$0F
	+8g	\$7F

MINIMUM RECOMMENDED FOOTPRINT FOR SURFACE MOUNTED APPLICATIONS

Surface mount board layout is a critical portion of the total design. The footprint for the surface mount packages must be the correct size to ensure proper solder connection interface between the board and the package.

With the correct footprint, the packages will self-align when subjected to a solder reflow process. It is always recommended to design boards with a solder mask layer to avoid bridging and shorting between solder pads.

SOLDERING AND MOUNTING GUIDELINES FOR THE LGA ACCELEROMETER SENSOR TO A PC BOARD

These guideline are for soldering and mounting the LGA package inertial sensors to printed circuit boards (PCBs). The purpose is to minimize the stress on the package after board mounting. The MMA7456L digital output accelerometer uses the Land Grid Array (LGA) package platform. This section describes suggested methods of soldering these devices to the PC board for consumer applications. [Figure 18](#) shows the recommended PCB land pattern for the package.

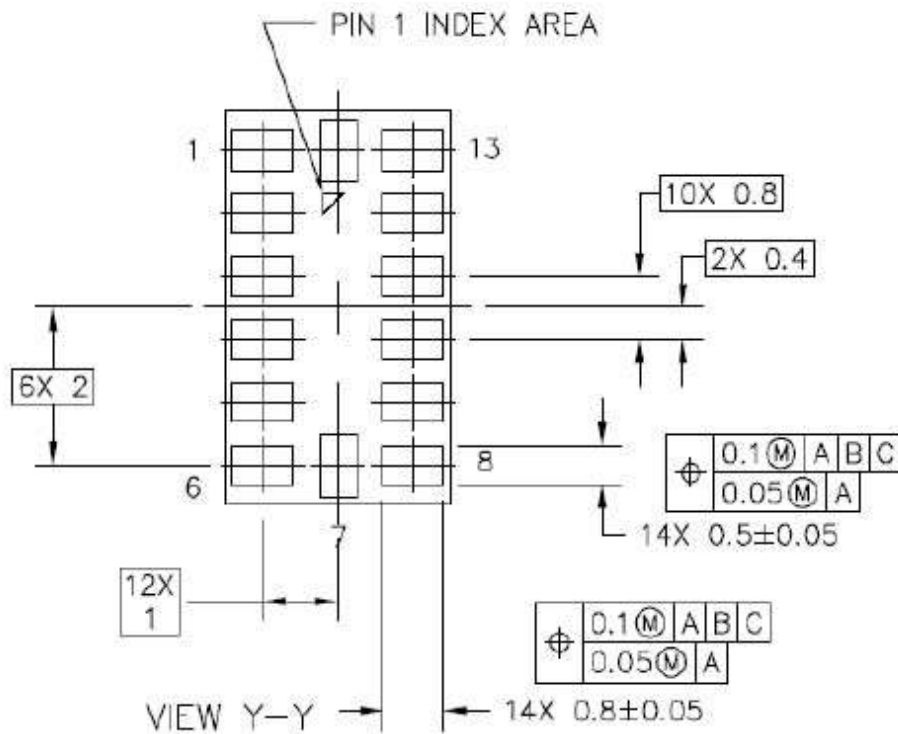

Figure 18. Recommended PCB Land Pattern for the 5 x 3 mm LGA Package

OVERVIEW OF SOLDERING CONSIDERATIONS

Information provided here is based on experiments executed on LGA devices. They do not represent exact conditions present at a customer site. Hence, information herein should be used as a guidance only and process and design optimizations are recommended to develop an application specific solution. It should be noted that with the proper PCB footprint and solder stencil designs the package will self-align during the solder reflow process.

The following are the recommended guidelines to follow for mounting LGA sensors for consumer applications.

PCB MOUNTING RECOMMENDATIONS

1. The PCB land should be designed with Non Solder Mask Defined (NSMD) as shown in [Figure 21](#).
2. No additional metal pattern underneath package as shown in [Figure 20](#).
3. PCB land pad is 0.9 mm x 0.6 mm which is the size of the package pad plus 0.1 mm as shown in [Figure 21](#).
4. The solder mask opening is equal to the size of the PCB land pad plus an extra 0.1 mm as shown in [Figure 21](#).
5. The stencil aperture size is equal to the PCB land pad – 0.025mm.

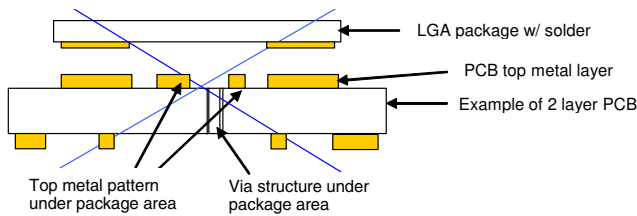

Figure 19. Incorrect PCB Top Metal Pattern Under Package



Figure 20. Correct PCB Top Metal Pattern Under Package

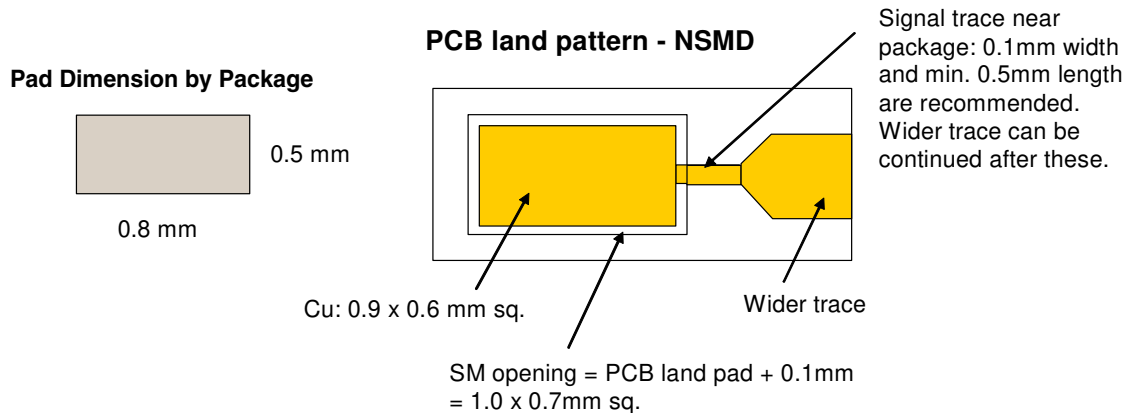

Figure 21. Recommended PCB Land Pad, Solder Mask, and Signal Trace Near Package Design

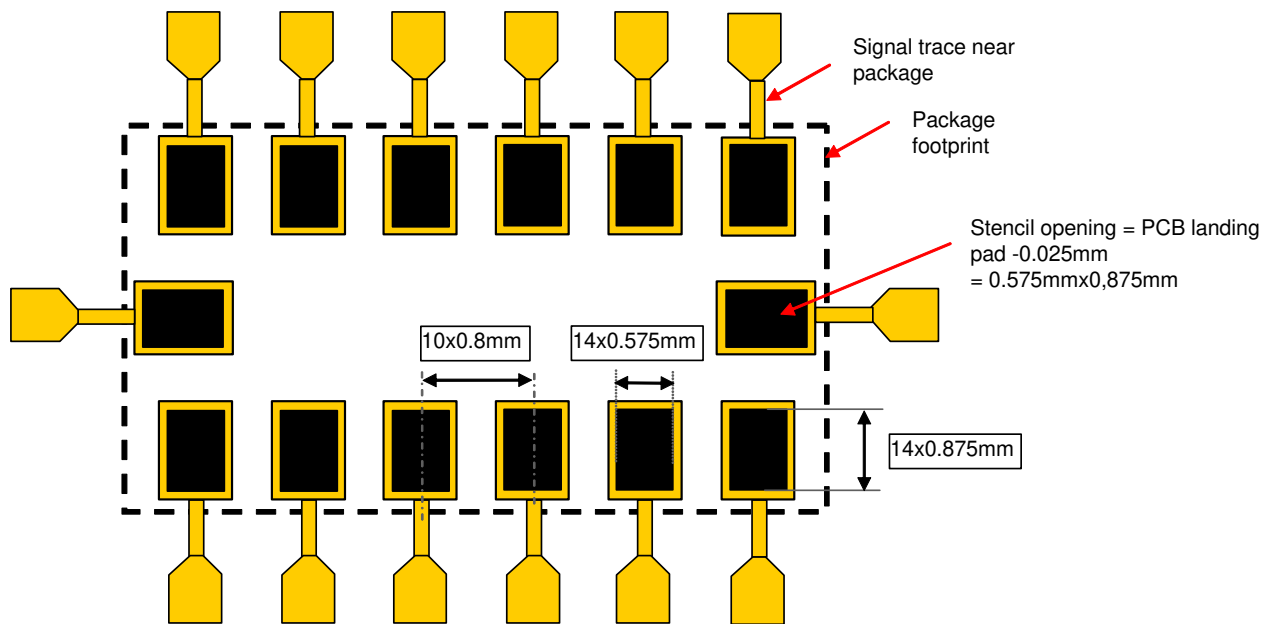

Figure 22. Stencil Design Guidelines

6. Do not place any components or vias at a distance less than 2 mm from the package land area. This may cause additional package stress if it is too close to the package land area.
7. Signal traces connected to pads should be as symmetric as possible. Put dummy traces on NC pads in order to have same length of exposed trace for all pads. Signal traces with 0.1 mm width and min. 0.5 mm length for all PCB land pads near the package are recommended as shown in [Figure 21](#) and [Figure 22](#). Wider trace can be continued after the 0.5 mm zone.
8. Use a standard pick and place process and equipment. Do not use a hand soldering process.
9. It is recommended to use a cleanable solder paste with an additional cleaning step after SMT mount.
10. Do not use a screw down or stacking to fix the PCB into an enclosure because this could bend the PCB putting stress on the package.
11. The PCB should be rated for the multiple lead-free reflow condition with max 260°C temperature.

Please cross reference with the device data sheet for mounting guidelines specific to the exact device used.

Freescale LGA sensors are compliant with Restrictions on Hazardous Substances (RoHS), having halide free molding compound (green) and lead-free terminations. These terminations are compatible with tin-lead (Sn-Pb) as well as tin-silver-copper (Sn-Ag-Cu) solder paste soldering processes. Reflow profiles applicable to those processes can be used successfully for soldering the devices.

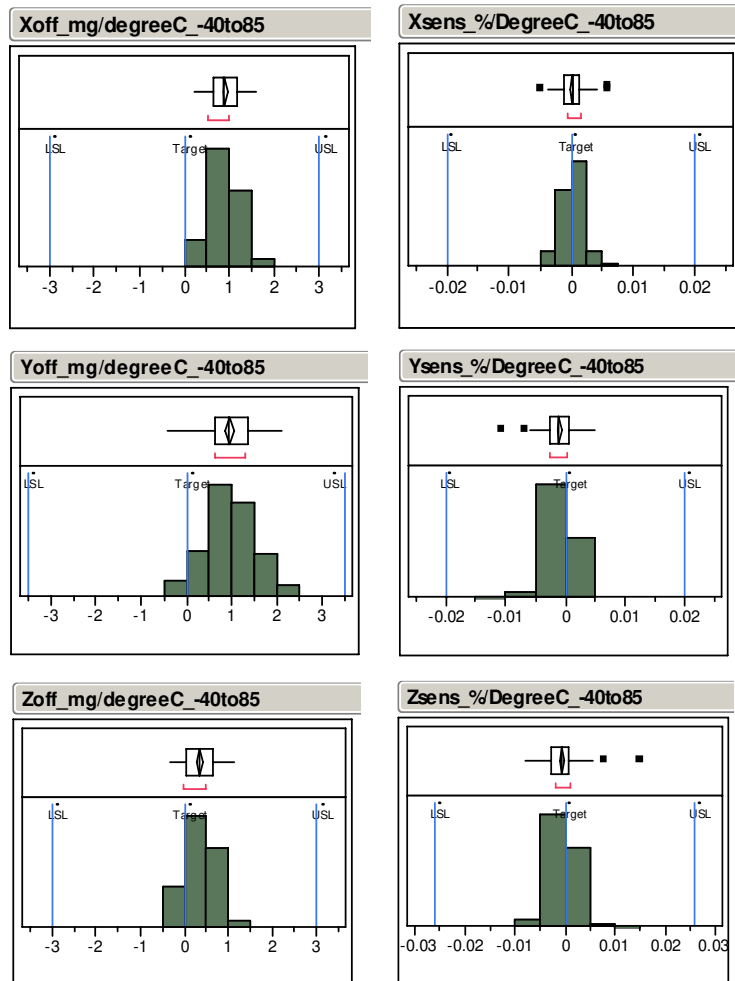

Figure 23. MMA7456L Temperature Coefficient of Offset (TCO) and Temperature Coefficient of Sensitivity (TCS) Distribution Charts

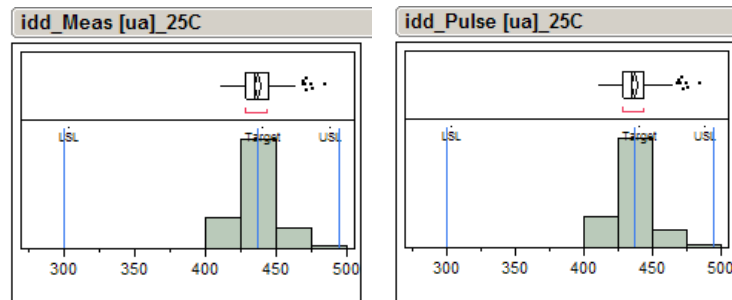
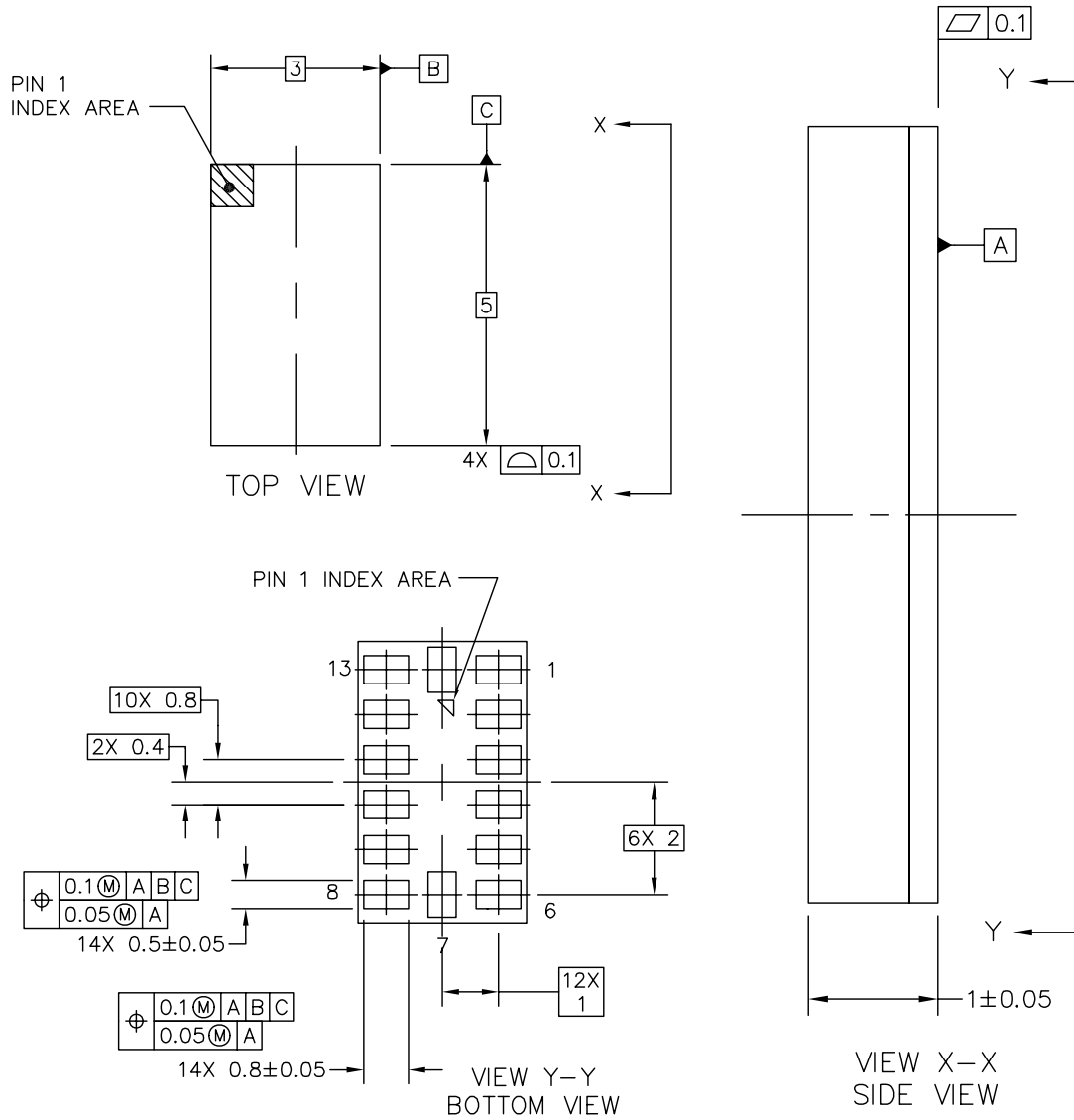

Figure 24. MMA7456L Current Distribution Charts

PACKAGE DIMENSIONS



© FREESCALE SEMICONDUCTOR, INC. ALL RIGHTS RESERVED.	MECHANICAL OUTLINE	PRINT VERSION NOT TO SCALE
TITLE: LGA 14 I/O, 3 X 5 X 1 PITCH 0.8, SENSOR 1.0MM PKG	DOCUMENT NO: 98ASA10801D	REV: A
	CASE NUMBER: 1977-01	09 JAN 2008
	STANDARD: NON-JEDEC	

**CASE 1977-01
ISSUE A
14-LEAD LGA**

PACKAGE DIMENSIONS

NOTES:

1. ALL DIMENSIONS IN MILLIMETERS.
2. DIMENSIONING AND TOLERANCING PER ASME Y14.5M-1994.

© FREESCALE SEMICONDUCTOR, INC. ALL RIGHTS RESERVED.	MECHANICAL OUTLINE	PRINT VERSION NOT TO SCALE	
TITLE: LGA 14 I/O, 3 X 5 X 1 PITCH 0.8, SENSOR 1.0MM PKG	DOCUMENT NO: 98ASA10801D	REV: A	
	CASE NUMBER: 1977-01	09 JAN 2008	
	STANDARD: NON-JEDEC		

**CASE 1977-01
 ISSUE A
 14-LEAD LGA**

How to Reach Us:

Home Page:

www.freescale.com

Web Support:

<http://www.freescale.com/support>

USA/Europe or Locations Not Listed:

Freescale Semiconductor, Inc.
Technical Information Center, EL516
2100 East Elliot Road
Tempe, Arizona 85284
1-800-521-6274 or +1-480-768-2130
www.freescale.com/support

Europe, Middle East, and Africa:

Freescale Halbleiter Deutschland GmbH
Technical Information Center
Schatzbogen 7
81829 Muenchen, Germany
+44 1296 380 456 (English)
+46 8 52200080 (English)
+49 89 92103 559 (German)
+33 1 69 35 48 48 (French)
www.freescale.com/support

Japan:

Freescale Semiconductor Japan Ltd.
Headquarters
ARCO Tower 15F
1-8-1, Shimo-Meguro, Meguro-ku,
Tokyo 153-0064
Japan
0120 191014 or +81 3 5437 9125
support.japan@freescale.com

Asia/Pacific:

Freescale Semiconductor China Ltd.
Exchange Building 23F
No. 118 Jianguo Road
Chaoyang District
Beijing 100022
China
+86 010 5879 8000
support.asia@freescale.com

For Literature Requests Only:

Freescale Semiconductor Literature Distribution Center
P.O. Box 5405
Denver, Colorado 80217
1-800-441-2447 or +1-303-675-2140
Fax: +1-303-675-2150
LDCForFreescaleSemiconductor@hibbertgroup.com

Information in this document is provided solely to enable system and software implementers to use Freescale Semiconductor products. There are no express or implied copyright licenses granted hereunder to design or fabricate any integrated circuits or integrated circuits based on the information in this document.

Freescale Semiconductor reserves the right to make changes without further notice to any products herein. Freescale Semiconductor makes no warranty, representation or guarantee regarding the suitability of its products for any particular purpose, nor does Freescale Semiconductor assume any liability arising out of the application or use of any product or circuit, and specifically disclaims any and all liability, including without limitation consequential or incidental damages. "Typical" parameters that may be provided in Freescale Semiconductor data sheets and/or specifications can and do vary in different applications and actual performance may vary over time. All operating parameters, including "Typicals", must be validated for each customer application by customer's technical experts. Freescale Semiconductor does not convey any license under its patent rights nor the rights of others. Freescale Semiconductor products are not designed, intended, or authorized for use as components in systems intended for surgical implant into the body, or other applications intended to support or sustain life, or for any other application in which the failure of the Freescale Semiconductor product could create a situation where personal injury or death may occur. Should Buyer purchase or use Freescale Semiconductor products for any such unintended or unauthorized application, Buyer shall indemnify and hold Freescale Semiconductor and its officers, employees, subsidiaries, affiliates, and distributors harmless against all claims, costs, damages, and expenses, and reasonable attorney fees arising out of, directly or indirectly, any claim of personal injury or death associated with such unintended or unauthorized use, even if such claim alleges that Freescale Semiconductor was negligent regarding the design or manufacture of the part.

Freescale™ and the Freescale logo are trademarks of Freescale Semiconductor, Inc. All other product or service names are the property of their respective owners.

© Freescale Semiconductor, Inc. 2009. All rights reserved.

RoHS-compliant and/or Pb-free versions of Freescale products have the functionality and electrical characteristics of their non-RoHS-compliant and/or non-Pb-free counterparts. For further information, see <http://www.freescale.com> or contact your Freescale sales representative.

For information on Freescale's Environmental Products program, go to <http://www.freescale.com/epp>.