

LOC		DIST		REVISIONS			
P	LTR	DESCRIPTION	DATE	DNW	APVD		
L		REV PER ECO 13-005678	4-6-13	CT	WB		

- CONNECTOR DIMENSIONS ARE PER ARINC 600 SPECIFICATION.
- CONNECTOR IS SUPPLIED WITH CONTACTS AS LISTED IN TABLE.
- KEYING SHOWN IN POSITION "01" FOR ILLUSTRATION ONLY. CONNECTORS SHIPPED WITH KEYING INSTALLED IN POSITION PER TABLE. FOR POSITION "00" KEYING HARDWARE SHIPPED UNASSEMBLED.
- DUST COVER INSTALLED FOR SHIPPING (NOT SHOWN).

COMPONENT	MATERIAL	FINISH
SHELL	DIE CAST ALUMINUM PER ASTM-B-85	ELECTROLESS NICKEL PER MIL-C-26074
INSERT RETENTION PLATES	ALUMINUM ALLOY PER ASTM-B-209	ELECTROLESS NICKEL PER MIL-C-26074
FLAT HEAD SCREWS	STAINLESS STEEL	PASSIVATED
POLARIZING KEYS	ZINC ALLOY PER ASTM-B-86	-
150 & 85 INSERTS	THERMOSET OR THERMOPLASTIC PPS PER MIL-M-24519	-
POLARIZING KEY RETAINING PLATE	ALUMINUM ALLOY PER ASTM-B-209	BLUE ANODIZED PER MIL-A-8625
DUMMY INSERT	ALUMINUM ALLOY PER ASTM-B-85	ELECTROLESS NICKEL PER MIL-C-26074

177	MODULE A 211431-2 (SIZE 22 POSTED; QTY=150) MODULE B (NONE) MODULE C 211431-2 (SIZE 22 POSTED; QTY=80) 208265-3 (SIZE 20 CRIMP; QTY=3) P4 & P5 (NOT INSTALLED) 208268-3 (SIZE 16 CRIMP; QTY=1) P3 (NOT INSTALLED)	1996164-3
91	MODULE A 211431-2 (SIZE 22 POSTED; QTY=150) MODULE B (NONE) MODULE C 211431-2 (SIZE 22 POSTED; QTY=80) 1663533-5 (SIZE 20 POSTED; QTY=2) P4, P5 208268-3 (SIZE 16 CRIMP; QTY=1) P3 (NOT INSTALLED) 208265-3 (SIZE 20 CRIMP; QTY=2) P1, P2 (NOT INSTALLED)	1996164-2
99	MODULE A 211431-2 (SIZE 22 POSTED; QTY=150) MODULE B (NONE) MODULE C 211431-2 (SIZE 22 POSTED; QTY=80) 1663533-5 (SIZE 20 POSTED; QTY=2) P4, P5 208268-3 (SIZE 16 CRIMP; QTY=1) P3 (NOT INSTALLED) 208265-3 (SIZE 20 CRIMP; QTY=2) P1, P2 (NOT INSTALLED)	1996164-1
KEYING POSITION	CONTACTS INCLUDED	PART NUMBER

THIS DRAWING IS A CONTROLLED DOCUMENT.		DIN P YEAGER 19JUL07	 TE Connectivity	
DIMENSIONS: INCHES		CHK K THACKSTON 19JUL07		
TOLERANCES UNLESS OTHERWISE SPECIFIED:		APVD K THACKSTON 19JUL07	NAME RCPT ASSY, SIZE 2, ARINC 600 (150/DUMMY/85)	
0 PLC ± - 1 PLC ± - 2 PLC ± - 3 PLC ± - 4 PLC ± - ANGLES ± -		PRODUCT SPEC		RESTRICTED TO
MATERIAL SEE TABLE		APPLICATION SPEC		SIZE CAGE CODE DRAWING NO
FINISH SEE TABLE		WEIGHT		A1 00779 1996164
		CUSTOMER DRAWING		SCALE 3:2 SHEET 1 OF 2 REV

LOC		DIST		REVISIONS			
P	LTR	DESCRIPTION	DATE	DNW	APVD		
SEE SHEET 1							

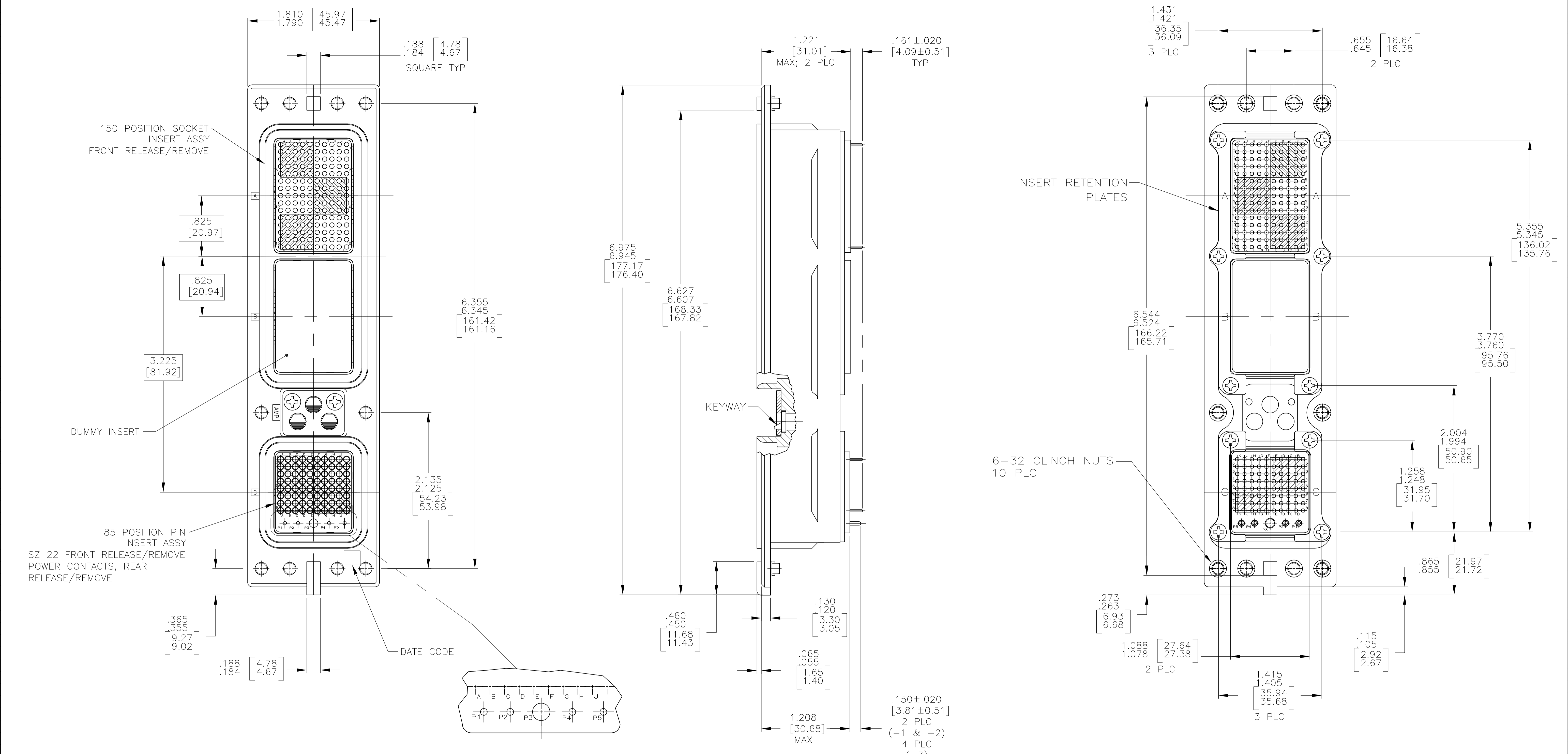

SEE TABLE FOR DESCRIPTION OF COMPONENTS FOR P1 THRU P5

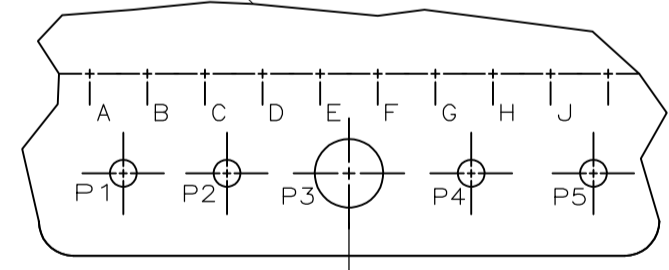

THIS DRAWING IS A CONTROLLED DOCUMENT.		DWG P. YEAGER 19JUL07 CHK K. THACKSTON 19JUL07 APVD K. THACKSTON 19JUL07	TE Connectivity	
DIMENSIONS: INCHES TOLERANCES UNLESS OTHERWISE SPECIFIED: 0 PLC ± - 1 PLC ± - 2 PLC ± - 3 PLC ± - 4 PLC ± - ANGLES ± -	MATERIAL SEE TABLE FINISH SEE TABLE	NAME RCPT ASSY, SIZE 2, ARINC 600 (150/DUMMY/85) APPLICATION SPEC WEIGHT CUSTOMER DRAWING	SIZE A1 CAGE CODE 00779 DRAWING NO. 1996164 SCALE 3:2	RESTRICTED TO SHEET 2 OF 2 REV L