

THIS DRAWING IS UNPUBLISHED. RELEASED FOR PUBLICATION .19
 BY AMP INCORPORATED. ALL RIGHTS RESERVED.

LOC		DIST		REVISIONS					
DY		-		P	LTR	DESCRIPTION	DATE	DWN	APVD
				AI		REVISED PER ECO-17-018857	28DEC2017	R.L	H.L

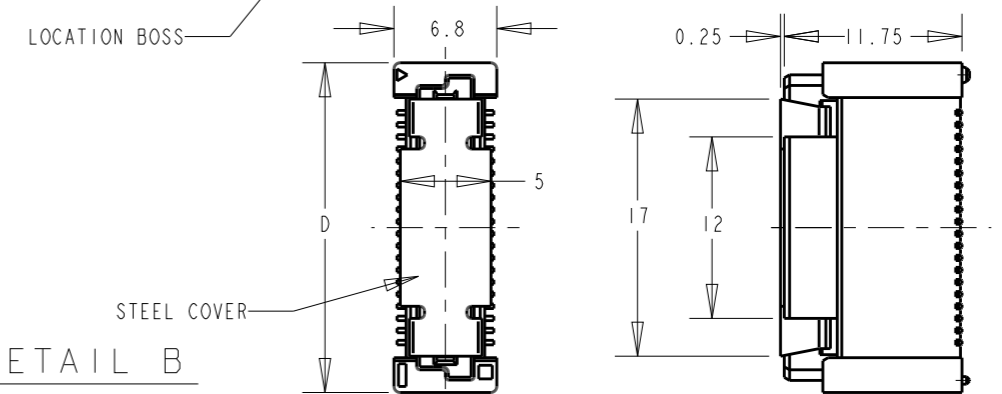

WINDING THE COVER TAPE
 AROUND THE OUTER
 PERIPHERY IN A TURN.

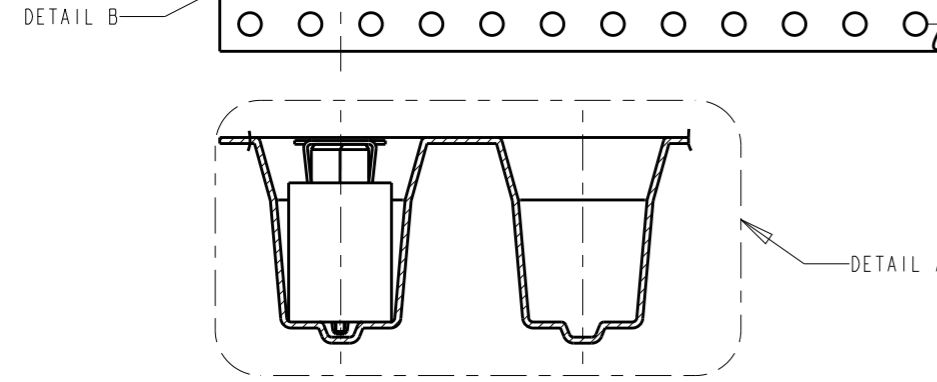
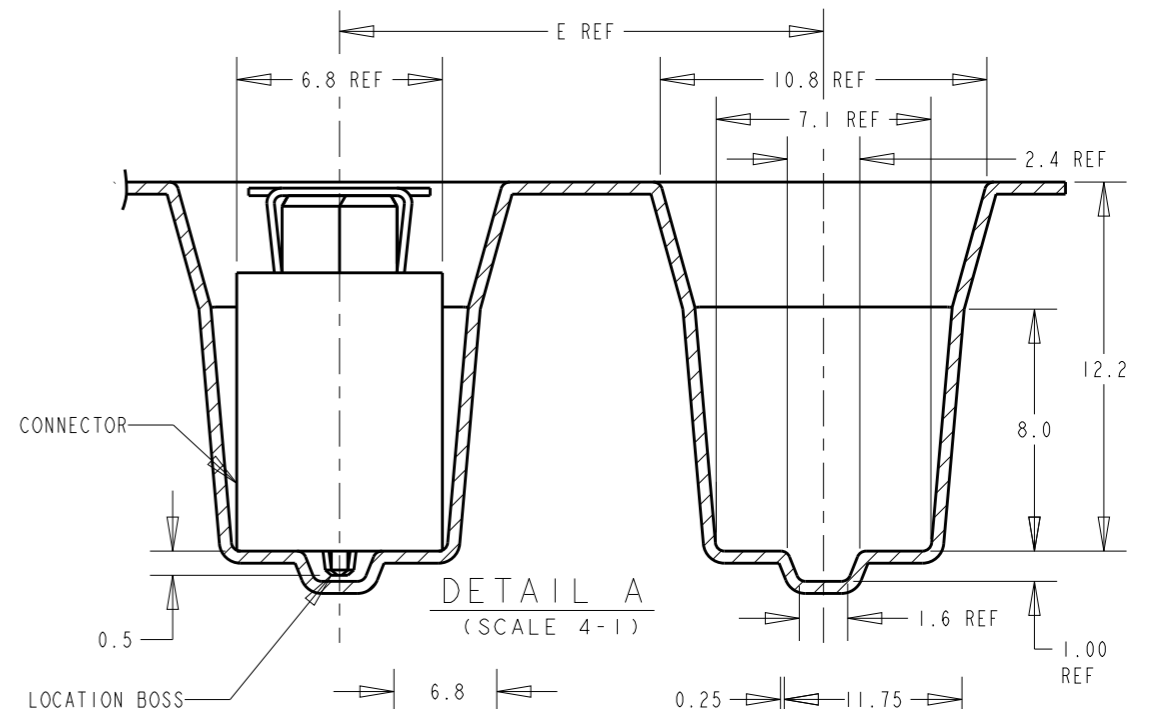
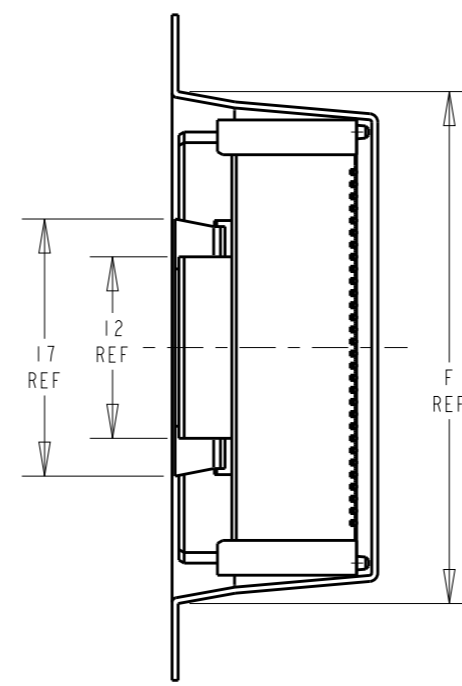
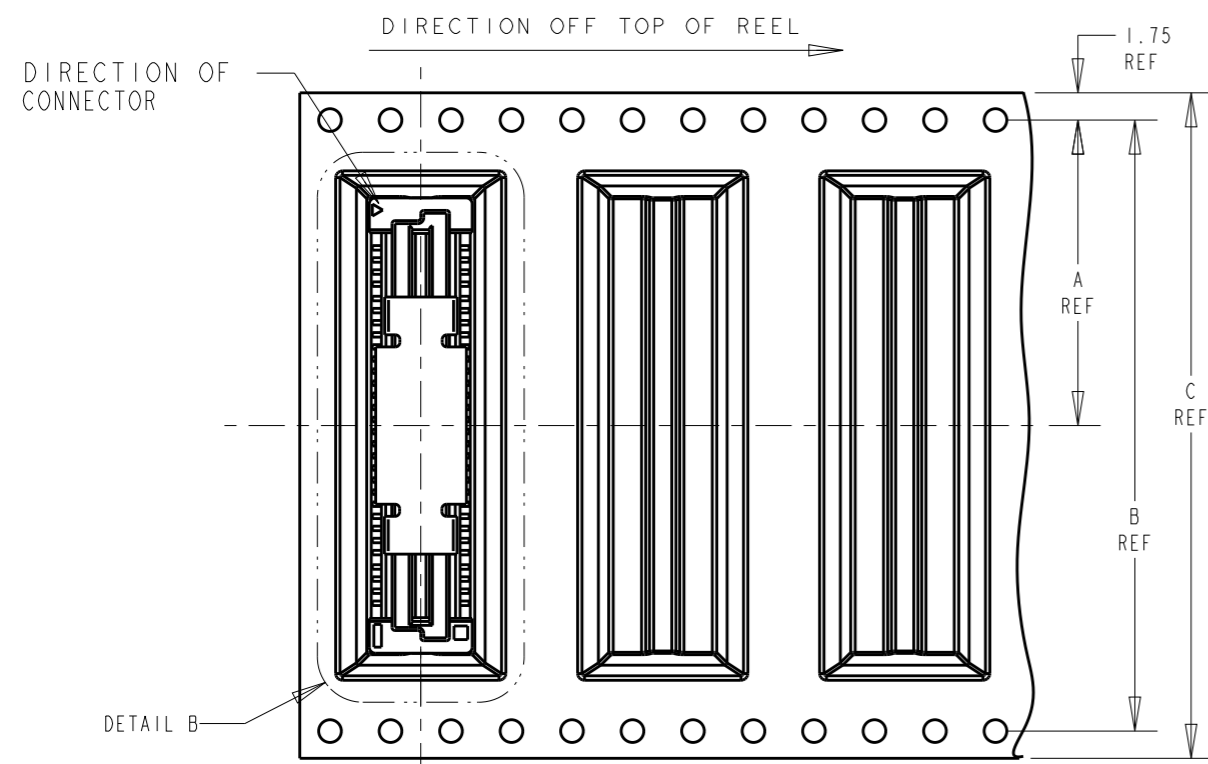
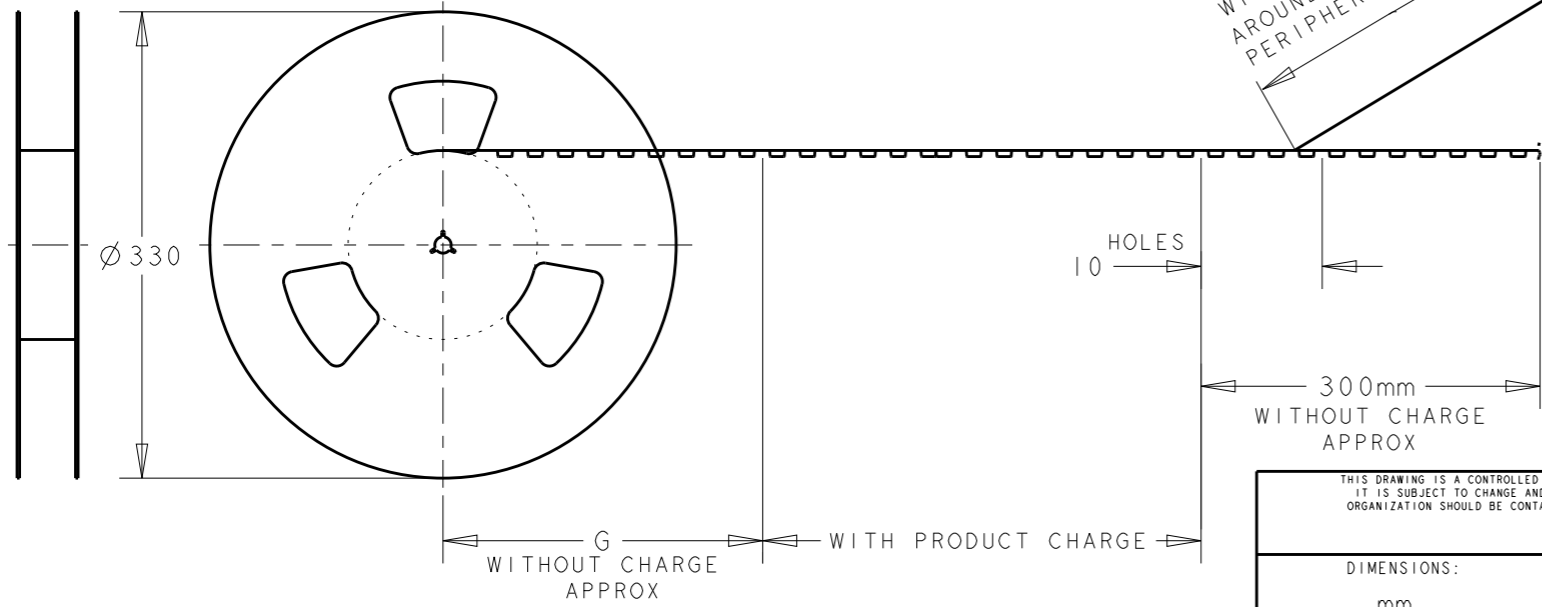

200	300	89.8	16	85.8	104	100.4	50.2	200	1-1735681-0
200	300	81.8	16	77.8	104	100.4	50.2	180	1735681-9
200	300	73.8	16	69.8	88	84.4	42.2	160	1735681-8
200	300	65.8	16	61.8	88	84.4	42.2	140	1735681-6
200	300	57.8	16	53.8	72	68.4	34.2	120	1735681-5
200	300	49.8	16	45.8	72	68.4	34.2	100	1735681-4
200	300	41.8	16	37.8	56	52.4	26.2	80	1735681-3
200	300	33.8	16	29.8	44	40.4	20.2	60	1735681-2
200	300	25.8	16	21.8	44	40.4	20.2	40	1735681-1
QTY	G	F	E	D	C	B	A	POS	PART NO.

THIS DRAWING IS A CONTROLLED DOCUMENT FOR AMP INCORPORATED. IT IS SUBJECT TO CHANGE AND THE CONTROLLING ENGINEERING ORGANIZATION SHOULD BE CONTACTED FOR THE LATEST REVISION.		DWN FLORENCE TAN 01SEP04	AMP Tyco Electronics (Singapore) Pte. Ltd.
DIMENSIONS: mm		CHK ERIC TNG	
TOLERANCES UNLESS OTHERWISE SPECIFIED: 0 PLC ±- 1 PLC ±0.30 2 PLC ±0.25 3 PLC ±0.20 4 PLC ±- ANGLES ±-		APVD SE LEONG	NAME RECEPTACLE ASS'Y 13H TYPE (0.5 BOSS LENGTH) FOR FH 0.8mm B-T-B CONN. ON TAPING
MATERIAL -		PRODUCT SPEC 108-5390	
FINISH -		APPLICATION SPEC 114-5254	SIZE A3
		WEIGHT -	CAGE CODE 00779
		CUSTOMER DRAWING	DRAWING NO 1735681
			SCALE 2:1 SHEET 1 OF 2 REV A1

ADD CONNECTOR INFORMATION SHEET

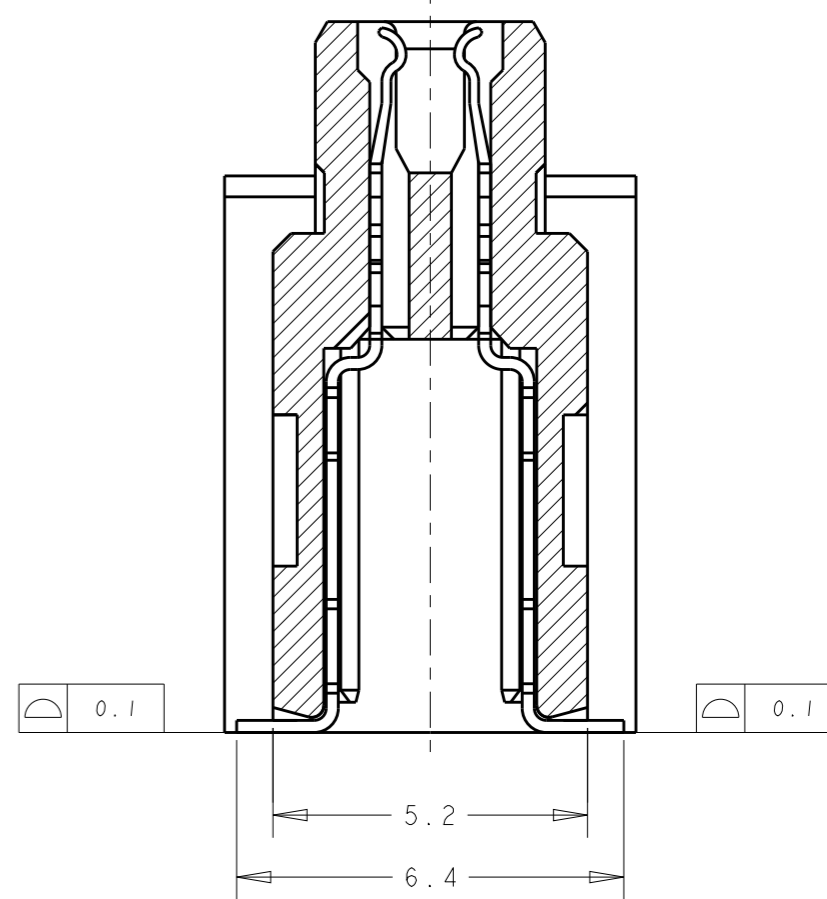
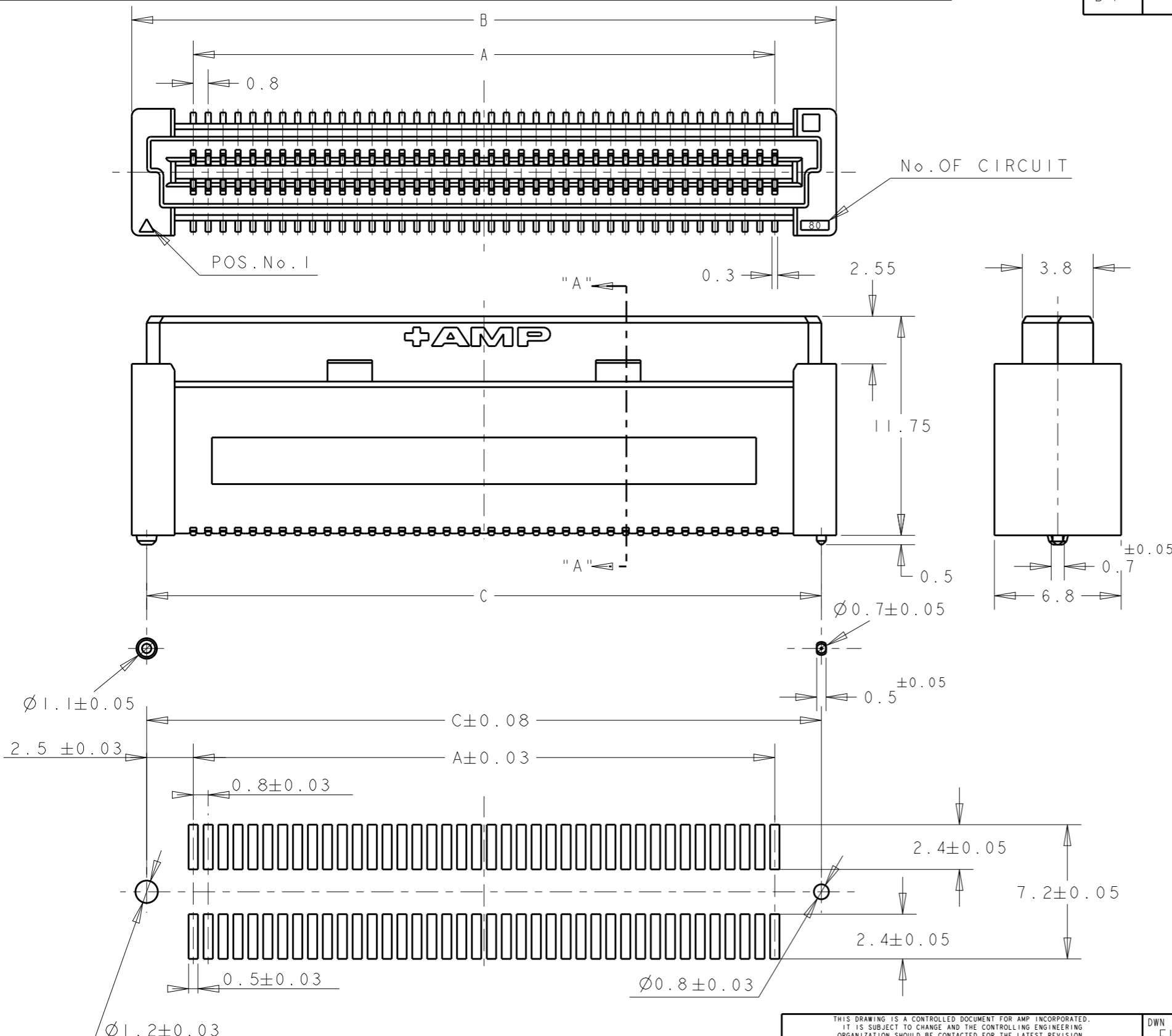

	84.20	85.80	79.20	200	1-	-0
	76.20	77.80	71.20	180		-9
	68.20	69.80	63.20	160		-8
	60.20	61.80	55.20	140		-6
	52.20	53.80	47.20	120		-5
	44.20	45.80	39.20	100		-4
	36.20	37.80	31.20	80		-3
	28.20	29.80	23.20	60		-2
0.5	20.20	21.80	15.20	40		1735681-1
D	C	B	A	POS.	PART No.	

NOTES:
 △ MATERIALS:
 HOUSING: L.C.P (HIGH TEMP THERMO-PLASTIC)
 UL 94V-0, NATURAL.
 CONTACT: COPPER ALLOY.
 △ FINISH:
 ENGAGEMENT AREA: 0.00038 MIN GOLD
 SOLDERING AREA: 0.002 MIN MATTE TIN
 UNDERCOAT: 0.0013 MIN NICKEL ALL OVER

RECOMMENDED P.C. BOARD LAYOUT

THIS DRAWING IS A CONTROLLED DOCUMENT FOR AMP INCORPORATED. IT IS SUBJECT TO CHANGE AND THE CONTROLLING ENGINEERING ORGANIZATION SHOULD BE CONTACTED FOR THE LATEST REVISION.		DWN FLORENCE TAN 01SEP04	Tyco Electronics Singapore Pte. Ltd.
DIMENSIONS: mm	TOLERANCES UNLESS OTHERWISE SPECIFIED:	CHK ERIC TNG	
	0 PLC ± 1 PLC ±0.30 2 PLC ±0.25 3 PLC ±0.20 4 PLC ± ANGLES ±	APVD SEIFONG	
		PRODUCT SPEC 108-5390	
MATERIAL	FINISH	APPLICATION SPEC 114-5254	NAME RECEPTACLE ASS'Y 13H TYPE (0.5 BOSS LENGTH) FOR FH 0.8mm B-T-B CONN. ON TAPING
		WEIGHT	SIZE A3
		CUSTOMER DRAWING	CAGE CODE 00779
			DRAWING NO 1735681
			SCALE 2:1
			SHEET 2 OF 2
			REV A1