

LOC	DIST	REVISIONS			
P	LTN	DESCRIPTION	DATE	DWN	APVD
GP	00				
A		REV PER 0S12-0650-04	17MAY2005	RG	MP
A1		ADDED NEW DASH NUMBER	7JUN2007	SZ	SY
A2		ADDED NEW DASH NUMBER	24OCT2007	DZ	SY
A3		REV PER ECR-13-004638	20MAR2013	ML	SZ

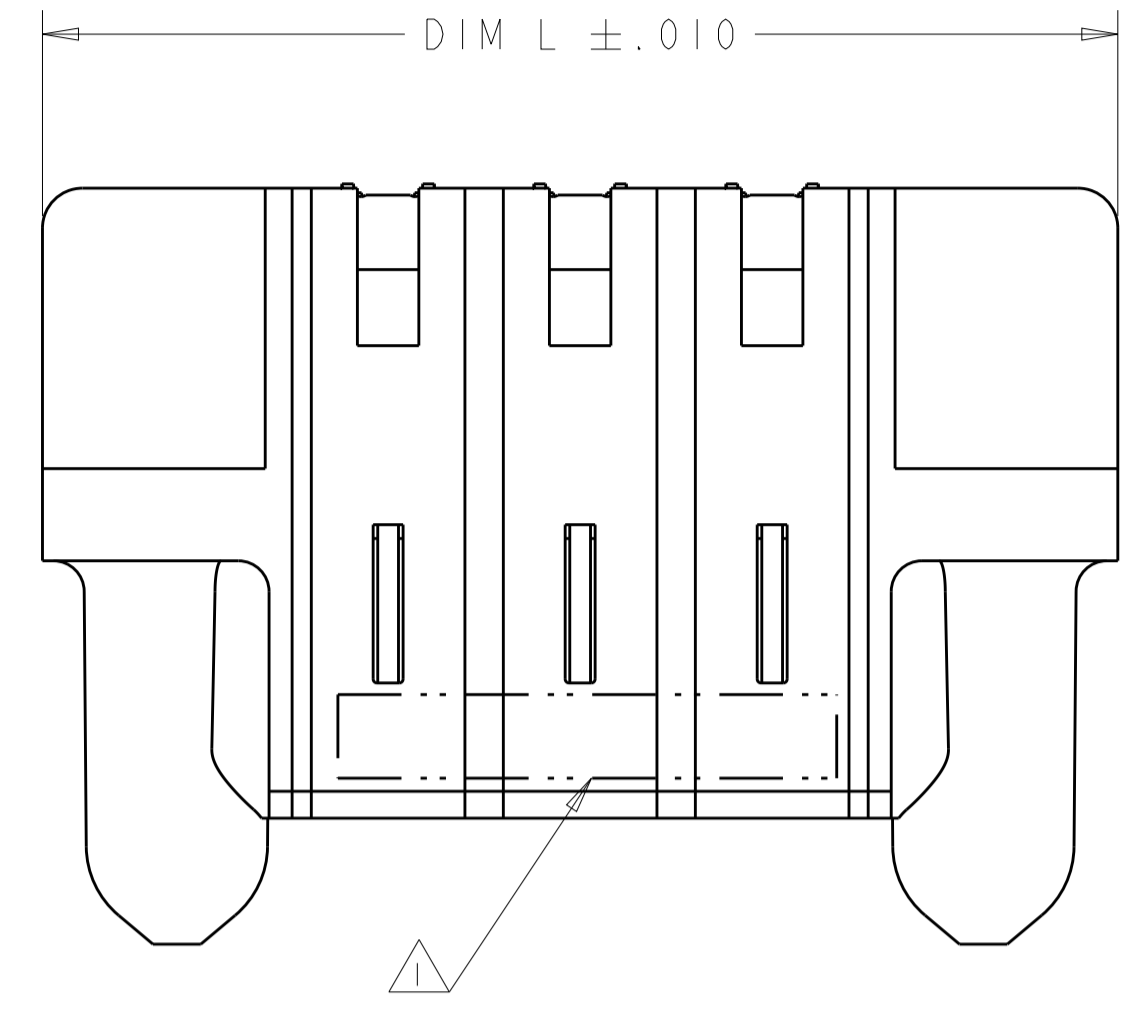

- △ "AMP", PART NUMBER, AND DATE CODE TO BE MARKED IN AREA SHOWN. PARTS UNDER 2.00 LONG MAY BE MARKED ON BOTH SIDES.
- △ MATERIAL: HOUSING - GLASS FILLED HIGH TEMP THERMO PLASTIC, UL94 V-O, BLACK  
POWER CONTACT - HIGH CONDUCTIVITY COPPER ALLOY
- △ CONTACT PLATING: NOBLE METAL PLATING ON CONTACT FUNCTIONAL AREA OF POWER AND SIGNAL CONTACTS
- △ MECHANICAL CONNECTOR KEEP OUT ZONE.
- △ DATUM AND BASIC DIMENSIONS ESTABLISHED BY CUSTOMER.
- △ PCB- ALL HOLE DIAMETERS ARE FINISHED HOLE SIZES.
- △ PCB- .0453 +/- .0010 DIA DRILLED HOLES PLATED WITH .0003 MIN Sn OVER .001-.003 PLATING TO ACHIEVE .040 DIA HOLE.
- △ VARIABLE DIMENSION SHOWS ON TABLE

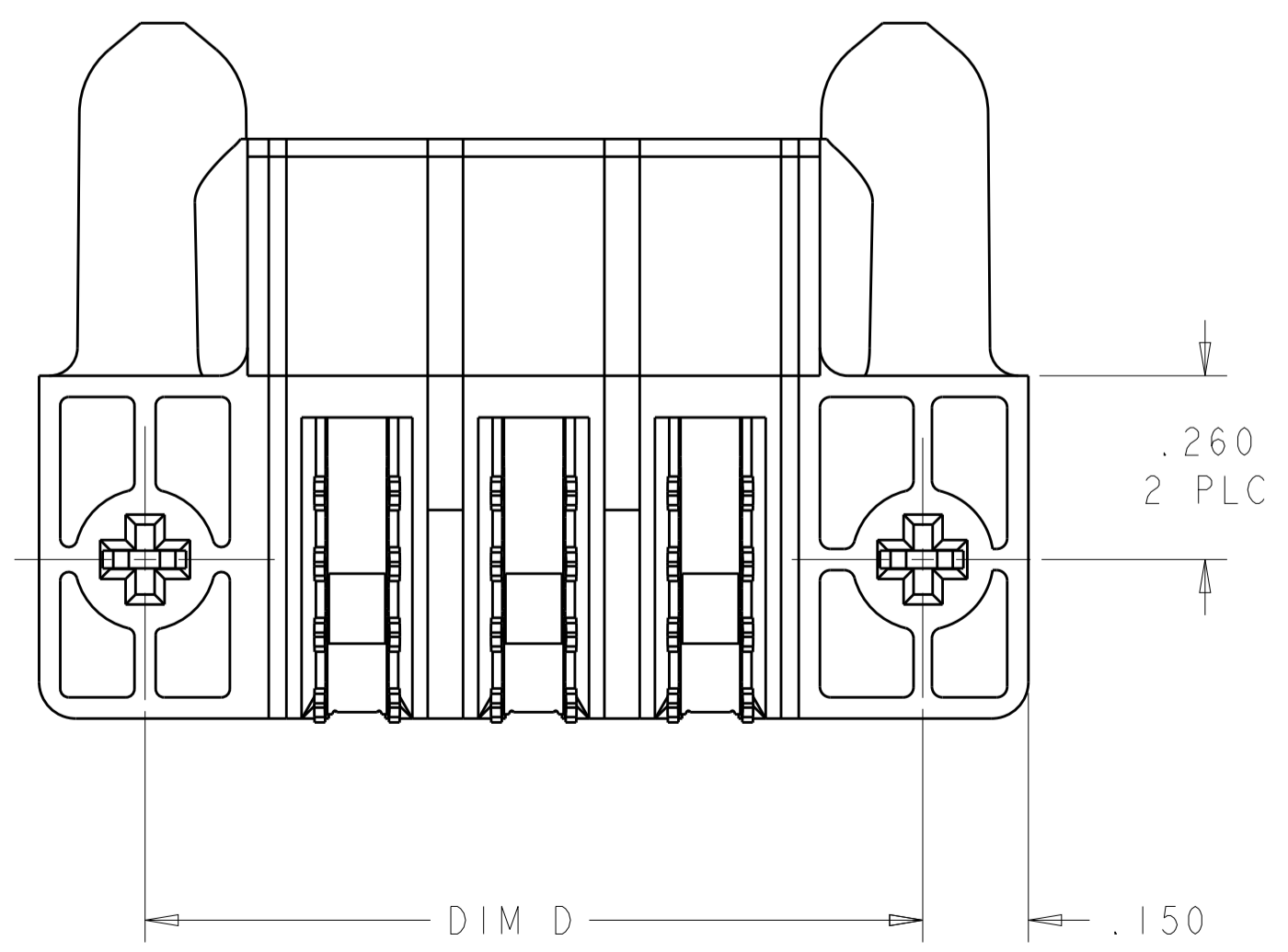
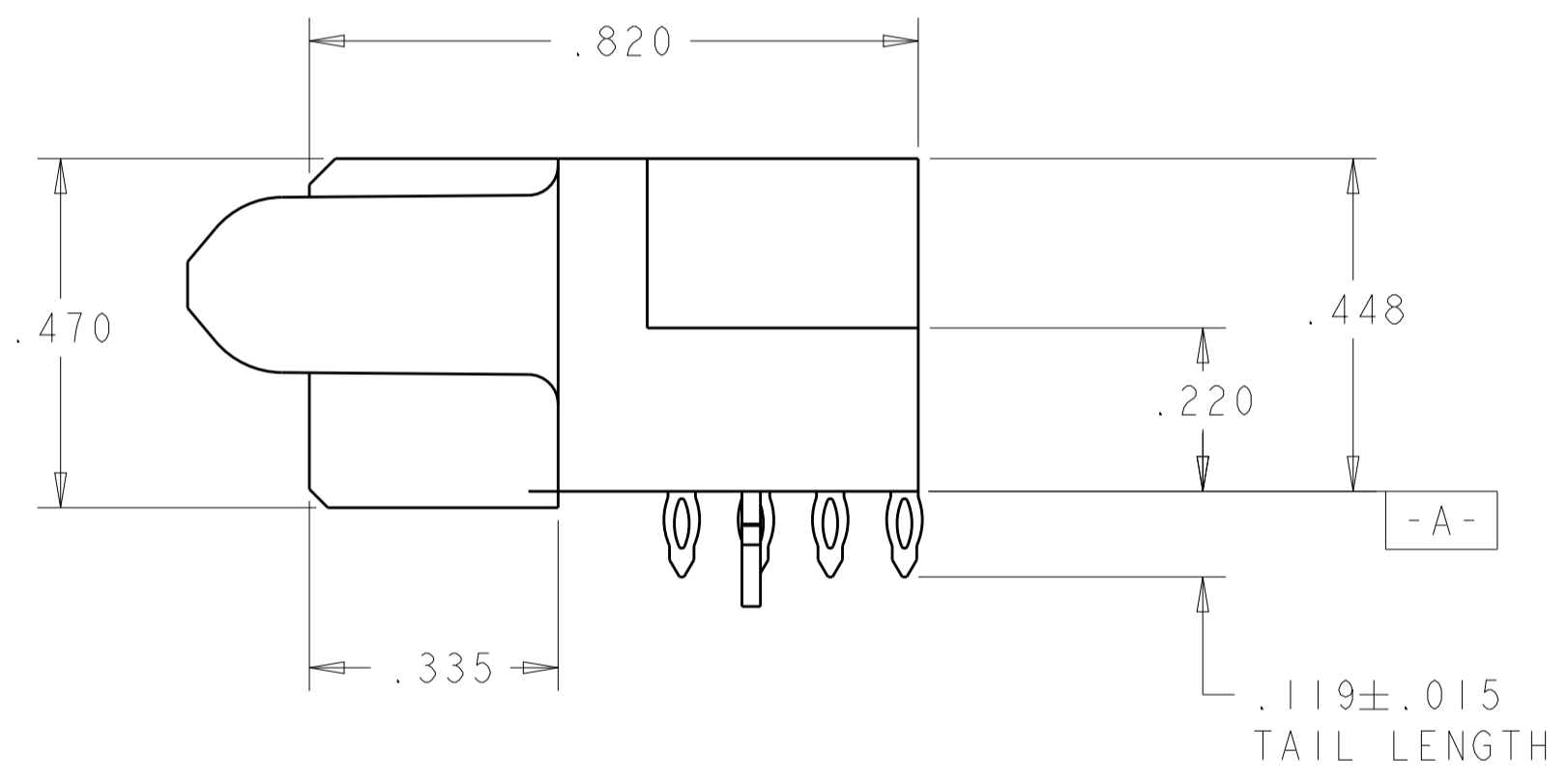
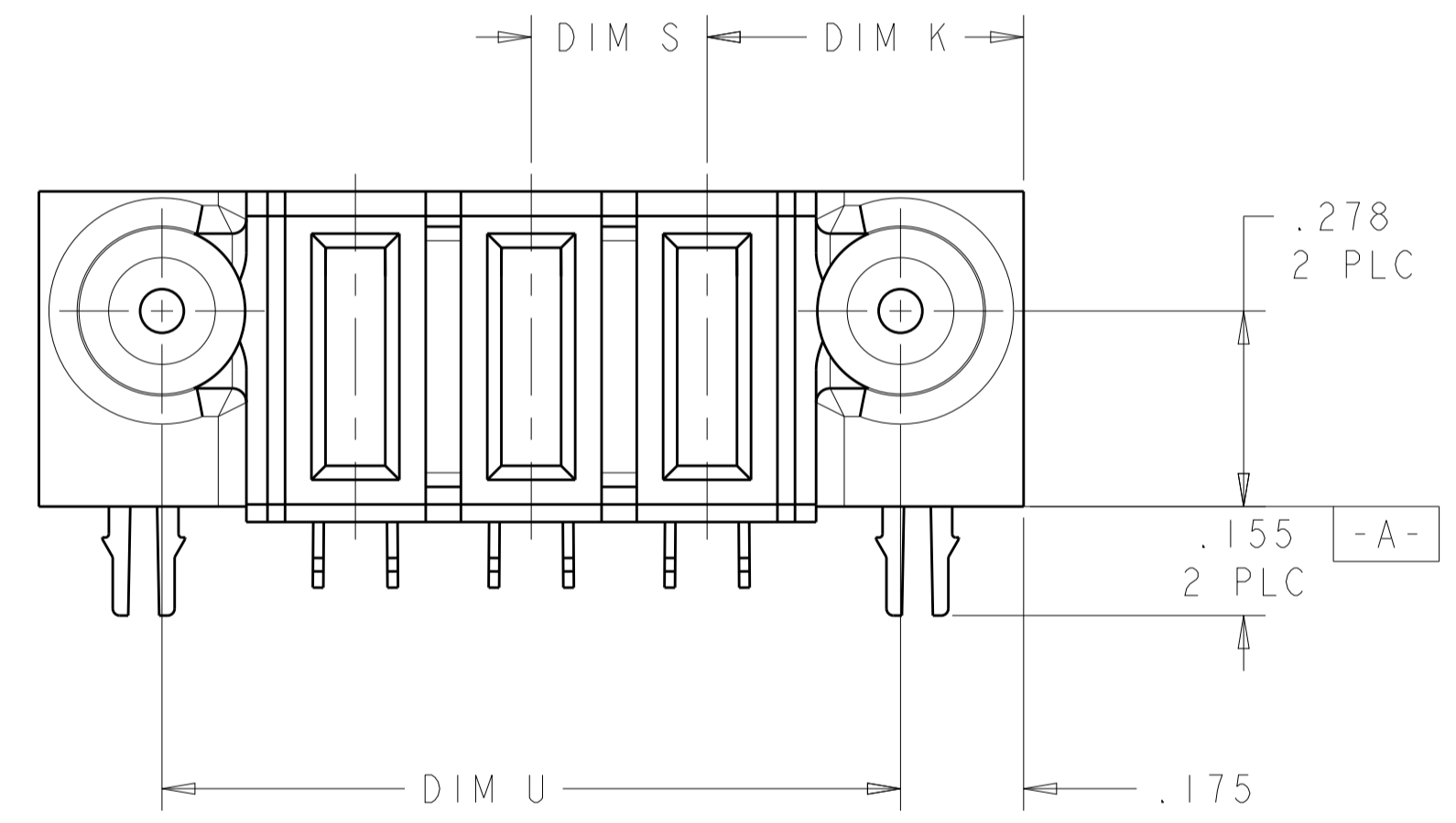

.250	1.300	1.350	1.650	.450	4P	6450563-4
△	1.700	1.750	2.050	.450	6P	6450563-3
.250	1.050	1.100	1.400	.450	3P	6450563-1
S	U	D	L	K	DESCRIPTION	PART NUMBER

DIMENSIONS: INCHES 		TOLERANCES UNLESS OTHERWISE SPECIFIED: 0 PLC ± 1 PLC ±.01 2 PLC ±.01 3 PLC ±.005 4 PLC ±.0020 ANGLES ±.7°		DWN R. GRZYBOWSKI 17MAY05 CHK M. PERCHERKE 17MAY05 APVD M. PERCHERKE PRODUCT SPEC 108-1973 APPLICATION SPEC 114-13038 FINISH 2 WEIGHT Customer Drawing		Tyco Electronics Corporation Shanghai, P.R. China, 200233 NAME RIGHT ANGLE RECEPTACLE ASSEMBLY WITH GUIDES MULTI-BEAM XL SIZE CAGE CODE DRAWING NO A100779C=6450563 RESTRICTED TO SCALE 2:1 SHEET 1 OF 2 REV A3	
---------------------------	--	---	--	---	--	--	--

PART NUMBER	ROWS	POWER		
		P3	P2	P1
6450563-1	D C B A	RP	RP	RP
		HD		HD
3P				

PART NUMBER	ROWS	POWER					
		P6	P5	P4	P3	P2	P1
6450563-3	D C B A	RP	RP	RS	RS	RS	RS
		HD					HD
6P							

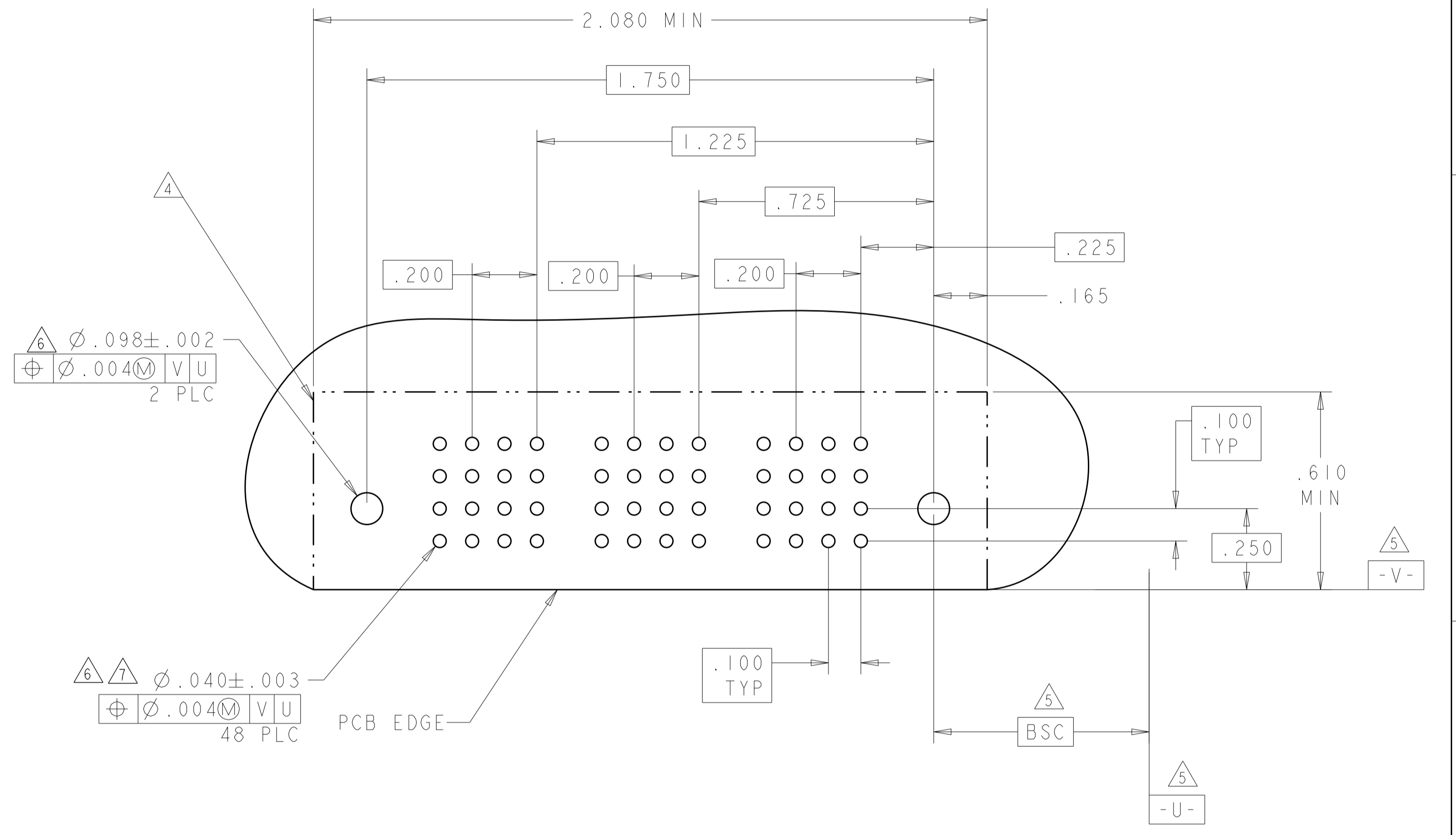
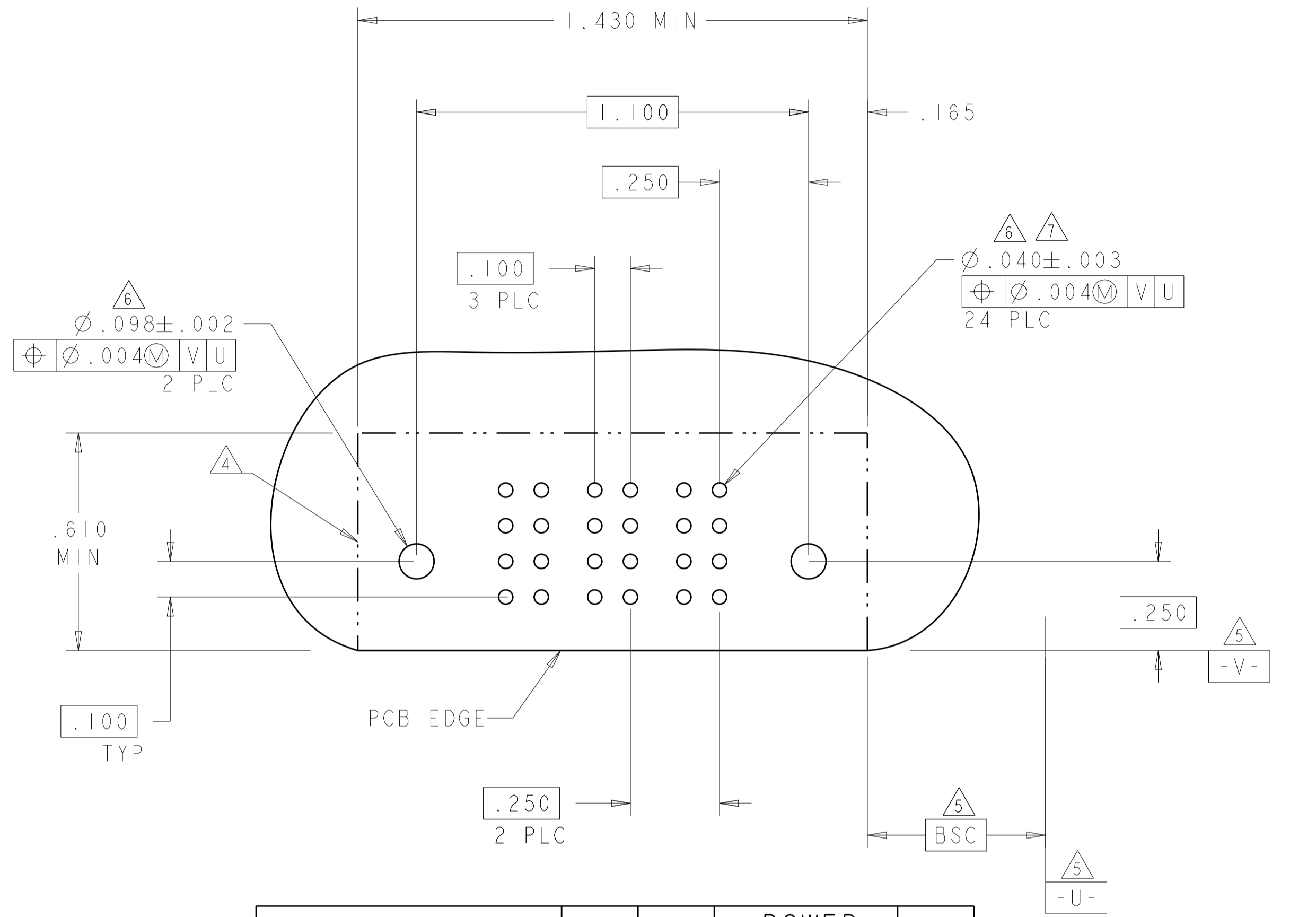

PART NUMBER	ROWS	POWER			
		P4	P2	P3	P1
6450563-4	D C B A	RS	RS	RS	RS
		HD			HD
4P					

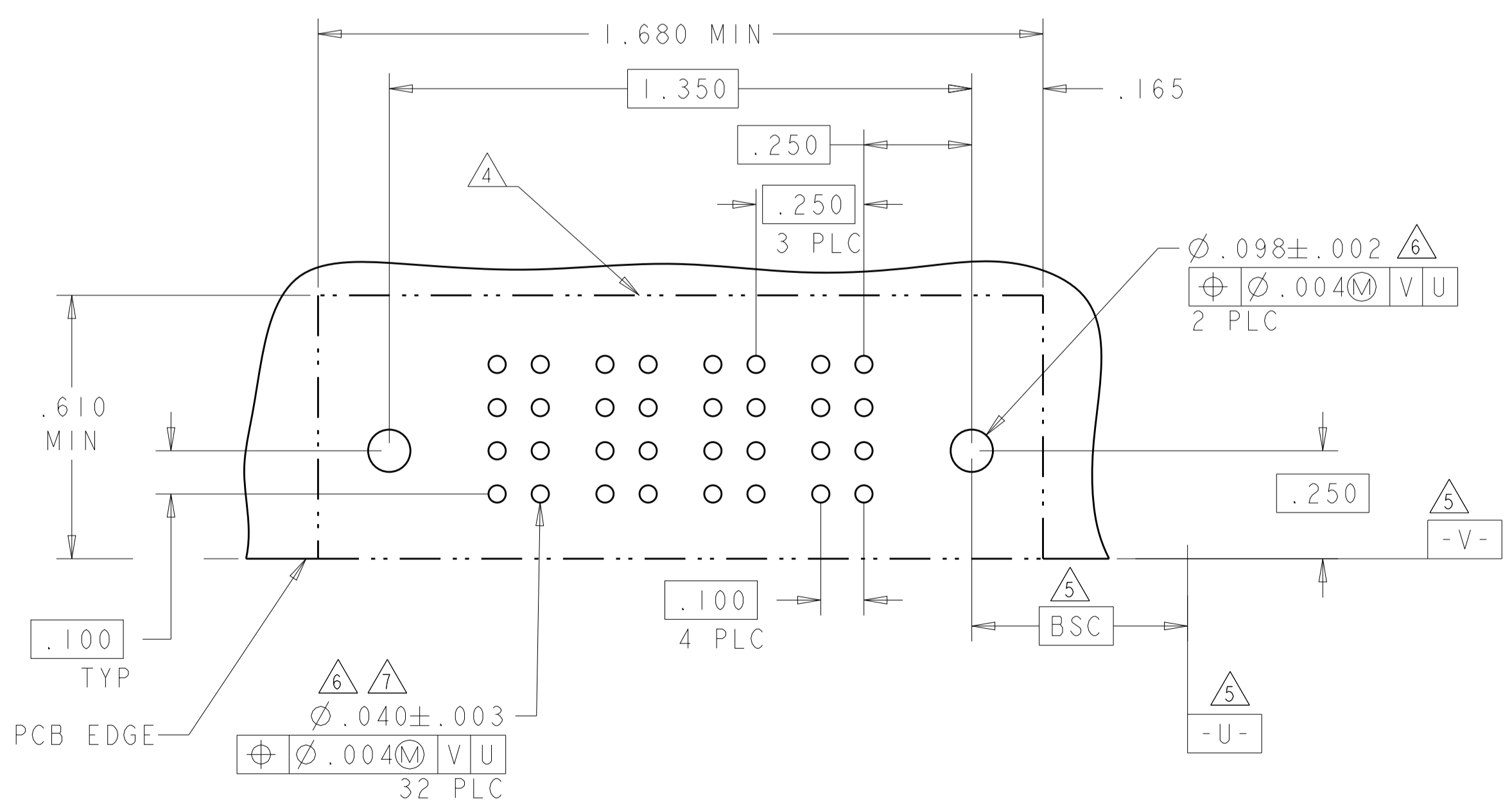

RP	PRESS FIT, MFBL
RS	PRESS FIT, STD
CODE	DESCRIPTION
	POWER CONTACT

<small>THIS DRAWING IS UNPUBLISHED. RELEASED FOR PUBLICATION. COPYRIGHT 20 BY TYCO ELECTRONICS CORPORATION. ALL RIGHTS RESERVED.</small>		DWN: R. GRZYBOWSKI 17MAY05 CHK: M. PERCHERKE 17MAY05 APVD: M. PERCHERKE PRODUCT SPEC: 108-1973 APPLICATION SPEC: 114-13038 WEIGHT: - SCALE: 2:1	Tyco Electronics Corporation Shanghai, P.R. China, 200233 NAME: RIGHT ANGLE RECEPTACLE ASSEMBLY WITH GUIDES MULTI-BEAM XL SIZE: A1100779 CAGE CODE: 6450563 SHEET 2 OF 2 REV A3
DIMENSIONS: INCHES TOLERANCES UNLESS OTHERWISE SPECIFIED: 0 PLC ±. 1 PLC ±.01 2 PLC ±.01 3 PLC ±.005 4 PLC ±.0020 ANGLES ±.020		MATERIAL: - FINISH: - CUSTOMER DRAWING	