

## 02312AXF-C

Huawei® 02312AXF Compatible TAA Compliant 50GBase-ER1 QSFP28 Transceiver Single Lambda (SMF, 1310nm, 40KM, LC, DOM)

### Features:

- QSFP28 MSA compliant
- Hot pluggable 38 pin electrical interface
- 1x50G PAM4 LAN-WDM transmitter
- 26.5625 Gbit/s Channel Electrical Serial Interface (50GAUI-2)
- Maximum power consumption 4.5W
- LC duplex connector
- Supports 53.125Gb/s aggregate bit rate
- Up to 40km transmission on single mode fiber
- Operating case temperature: 0°C to 70°C
- Single 3.3V power supply
- RoHS 2.0 compliant



### Applications:

- 50GBASE-ER
- Telecom networking

### Product Description

This Huawei® 02312AXF compatible QSFP28 transceiver provides 50GBase-ER throughput up to 40km over single-mode fiber (SMF) using a wavelength of 1310nm via an LC connector. It is guaranteed to be 100% compatible with the equivalent Huawei® transceiver. This easy to install, hot swappable transceiver has been programmed, uniquely serialized and data-traffic and application tested to ensure that it will initialize and perform identically. Digital optical monitoring (DOM) support is also present to allow access to real-time operating parameters. This transceiver is Trade Agreements Act (TAA) compliant. We stand behind the quality of our products and proudly offer a limited lifetime warranty.

ProLabs' transceivers are RoHS compliant and lead-free.

TAA refers to the Trade Agreements Act (19 U.S.C. & 2501-2581), which is intended to foster fair and open international trade. TAA requires that the U.S. Government may acquire only "U.S. – made or designated country end products."



## Regulatory Compliance

- ESD to the Electrical PINs: compatible with MIL-STD-883E Method 3015.4
- ESD to the LC Receptacle: compatible with IEC/EN 61000-4-3
- EMI/EMC compatible with FCC Part 15 Subpart B Rules, EN55032
- Laser Eye Safety compatible with FDA 21CFR, EN60950-1& EN (IEC) 60825-1,2
- RoHS compliant with EU RoHS 2.0 directive 2015/863/EU

## Absolute Maximum Ratings

Parameter	Symbol	Min.	Typ.	Max.	Unit	Notes
Maximum Supply Voltage	Vcc	0		3.6	V	
Storage Temperature	TS	-40		85	°C	
Operating Case Temperature	Tc	0		70	°C	
Relative Humidity	RH	10		85	%	1
Data Rate			26.5625		GBd	
Aggregated Data Rate			53.125		Gbps	2
Damage Threshold	THd	-2.4			dBm	
Link Distance with G.652				40	km	

### Notes:

1. Non-condensing
2. IEEE 802.3cd-2018

## Electrical Characteristics

Parameter	Symbol	Min.	Typ.	Max.	Unit	Notes
Supply Voltage	Vcc	3.135	3.3	3.465	V	
Supply Current	Icc			1.36	A	1
Power dissipation				4.5	W	
<b>Transmitter</b>						2
Data Rate			26.5625		Gbps	
Differential Voltage pk-pk	Vpp			900	mV	
Common Mode Noise, RMS	Vrms			17.5	mV	
Differential Termination Resistance Mismatch				10	%	At 1 MHz
Transition time	Trise/Tfall	10			ps	20%~80%
Eye width	EW15	0.46			UI	
Eye height	EH15	95			mV	
<b>Receiver</b>						3
Data Rate			26.5625		Gbps	
Differential Voltage pk-pk	Vpp			900	mV	
Common Mode Voltage	Vcm	-350		2850	mV	
Common Mode Noise, RMS	Vrms			17.5	mV	
Transition time	Trise/Tfall	9.5			ps	20%~80%
Vertical Eye Closure (VEC)				5.5	dB	
Eye width	EW15	0.57			UI	
Eye height	EH15	228			mV	

### Notes:

1. Maximum total power value is specified across the full temperature and voltage range.
2. Refer to OIF-CEI-03.1, CEI-28G-VSR Interface 13.3.2.
3. Refer to OIF-CEI-03.1, CEI-28G-VSR Interface 13.3.3.

## Optical Characteristics

Parameter	Min.	Typ.	Max.	Unit	Notes
<b>Transmitter</b>					
Signaling Speed	26.5625 ± 100 ppm			Gb/s	
Transmit wavelengths	1304.5		1317.5	nm	
Side-Mode Suppression Ratio (SMSR)	30			dB	
Average Launch Power	1.5		8.0	dBm	
Outer Optical Modulation Amplitude, (OMA <sub>outer</sub> )	4.5		9.0	dBm	
Launch power in OMA <sub>outer</sub> minus TDECQ	2			dBm	
Transmitter and dispersion eye closure for PAM4 (TDECQ)			3.2	dB	
TDECQ-10log <sub>10</sub> (C <sub>eq</sub> )			3.2	dB	
Average launch power of OFF transmitter			-15	dBm	
Extinction Ratio (ER)	6			dB	
Transmitter transition time			34	ps	
Transmitter reflectance			-26	dB	
<b>Receiver</b>					
Signaling Speed	26.5625 ± 100 ppm			Gb/s	
Receive wavelengths	1304.5		1317.5	nm	
Average receiver power	-15		-3	dBm	
Receiver power (OMA <sub>outer</sub> )			-2.6	dBm	
Receiver reflectance			-26	dB	
Receiver sensitivity (OMA <sub>outer</sub> )			-13.5	dBm	
LOS Assert	-30			dBm	
LOS Deassert			-20	dBm	
LOS Hysteresis	0.5			dB	
<b>Conditions of stressed receiver sensitivity test:</b>					
Stressed eye closure for PAM4 (SECQ)		3.2		dB	
SECQ-10log <sub>10</sub> (C <sub>eq</sub> )			3.2	dBm	

## Pin Descriptions

Pin	Symbol	Name/Descriptions	Ref.
1	GND	Transmitter Ground (Common with Receiver Ground)	1
2	Tx2-	Transmitter Inverted Data Input	
3	Tx2+	Transmitter Non-Inverted Data output	
4	GND	Transmitter Ground (Common with Receiver Ground)	1
5	Tx4-	Transmitter Inverted Data Input	
6	Tx4+	Transmitter Non-Inverted Data output	
7	GND	Transmitter Ground (Common with Receiver Ground)	1
8	ModSelL	Module Select	2
9	ResetL	Module Reset	2
10	VccRx	3.3V Power Supply Receiver	
11	SCL	2-Wire serial Interface Clock	2
12	SDA	2-Wire serial Interface Data	2
13	GND	Transmitter Ground (Common with Receiver Ground)	1
14	Rx3+	Receiver Non-Inverted Data Output	
15	Rx3-	Receiver Inverted Data Output	
16	GND	Transmitter Ground (Common with Receiver Ground)	1
17	Rx1+	Receiver Non-Inverted Data Output	
18	Rx1-	Receiver Inverted Data Output	
19	GND	Transmitter Ground (Common with Receiver Ground)	1
20	GND	Transmitter Ground (Common with Receiver Ground)	1
21	Rx2-	Receiver Inverted Data Output	
22	Rx2+	Receiver Non-Inverted Data Output	
23	GND	Transmitter Ground (Common with Receiver Ground)	1
24	Rx4-	Receiver Inverted Data Output	1
25	Rx4+	Receiver Non-Inverted Data Output	
26	GND	Transmitter Ground (Common with Receiver Ground)	1
27	ModPrsl	Module Present	
28	IntL	Interrupt	2
29	VccTx	3.3V power supply transmitter	
30	Vcc1	3.3V power supply	
31	LPMODE	Low Power Mode	2
32	GND	Transmitter Ground (Common with Receiver Ground)	1
33	Tx3+	Transmitter Non-Inverted Data Input	
34	Tx3-	Transmitter Inverted Data Output	

35	GND	Transmitter Ground (Common with Receiver Ground)	1
36	Tx1+	Transmitter Non-Inverted Data Input	
37	Tx1-	Transmitter Inverted Data Output	
38	GND	Transmitter Ground (Common with Receiver Ground)	1

**Notes:**

1. The module signal grounds are isolated from the module case.
2. This is an open collector/drain output that on the host board requires a 4.7KΩ to 10KΩ pull-up resistor to Vcchost.

**Electrical Pin-out Details**

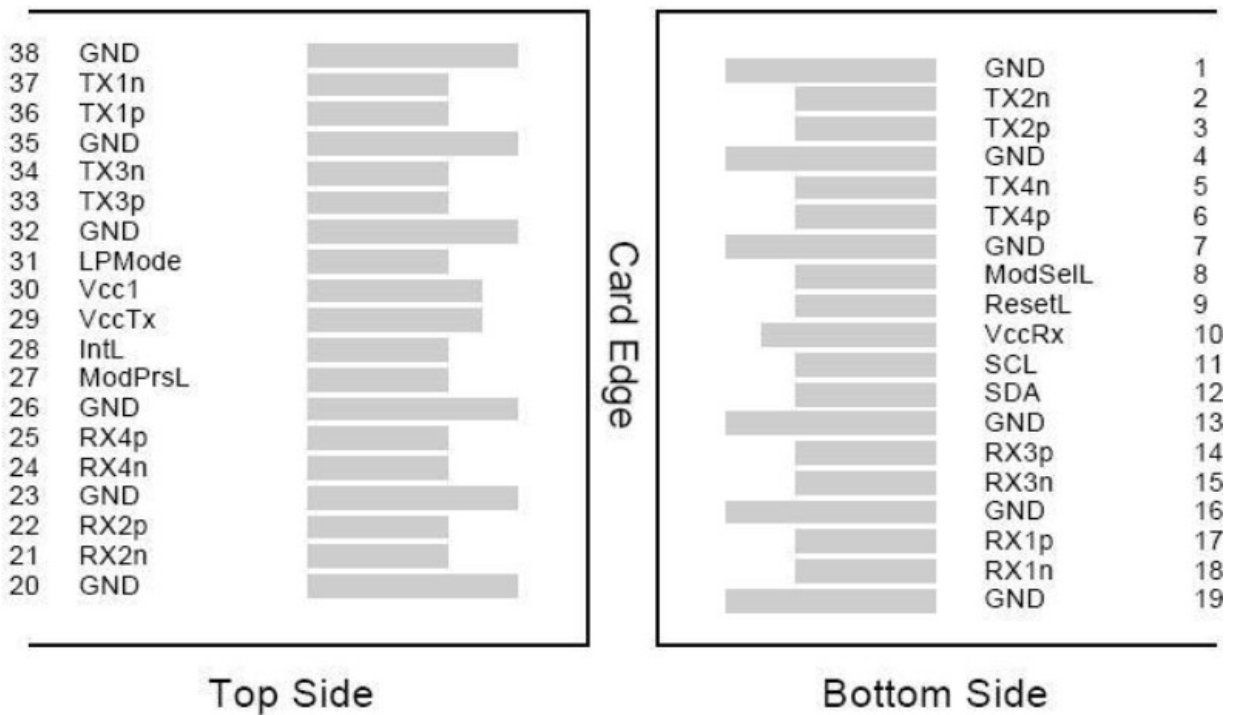

### Recommended Host Board Power Supply Filter Network

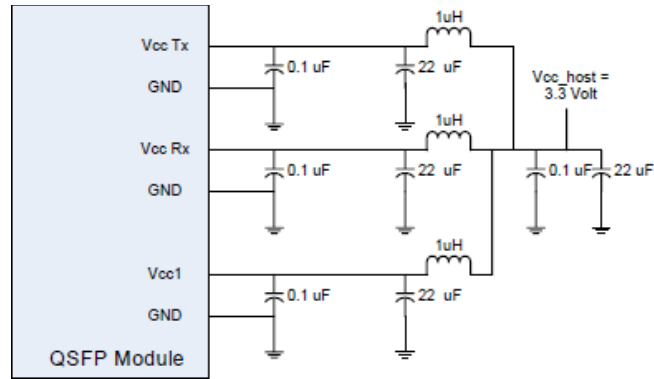

### Transceiver Block Diagram

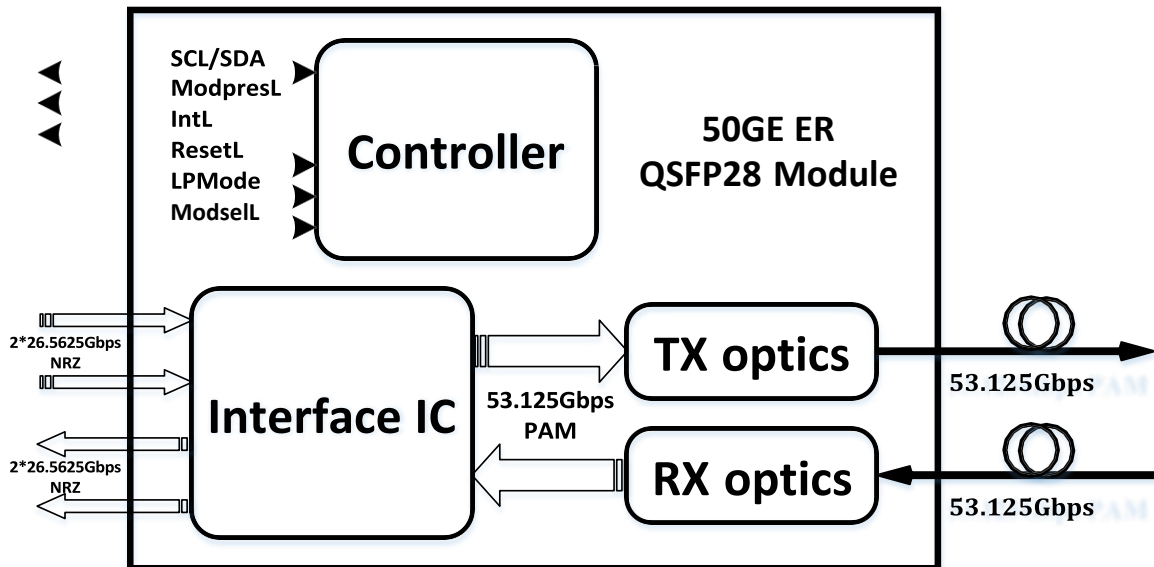

# Mechanical Specifications

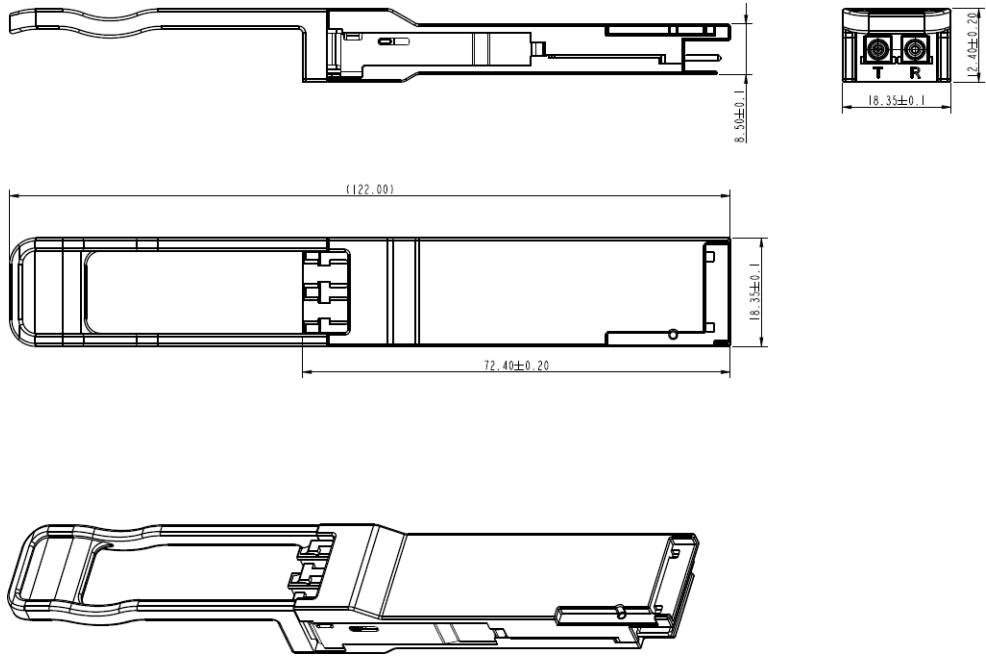



**About ProLabs**

Our experience comes as standard; for over 15 years ProLabs has delivered optical connectivity solutions that give our customers freedom and choice through our ability to provide seamless interoperability. At the heart of our company is the ability to provide state-of-the-art optical transport and connectivity solutions that are compatible with over 90 optical switching and transport platforms.

**Complete Portfolio of Network Solutions**

ProLabs is focused on innovations in optical transport and connectivity. The combination of our knowledge of optics and networking equipment enables ProLabs to be your single source for optical transport and connectivity solutions from 100Mb to 400G while providing innovative solutions that increase network efficiency. We provide the optical connectivity expertise that is compatible with and enhances your switching and transport equipment.

**Trusted Partner**

Customer service is our number one value. ProLabs has invested in people, labs and manufacturing capacity to ensure that you get immediate answers to your questions and compatible product when needed. With Engineering and Manufacturing offices in the U.K. and U.S. augmented by field offices throughout the U.S., U.K. and Asia, ProLabs is able to be our customers best advocate 24 hours a day.

**Contact Information**

ProLabs US

Email: [sales@prolabs.com](mailto:sales@prolabs.com)

Telephone: 952-852-0252

ProLabs UK

Email: [salessupport@prolabs.com](mailto:salessupport@prolabs.com)

Telephone: +44 1285 719 600