

LOC	DIST	REVISIONS			
CM	00	#	DATE	OWN	APVD
		P3	18JUN2018	BDA	SG
		R	09OCT2019	BDA	SW

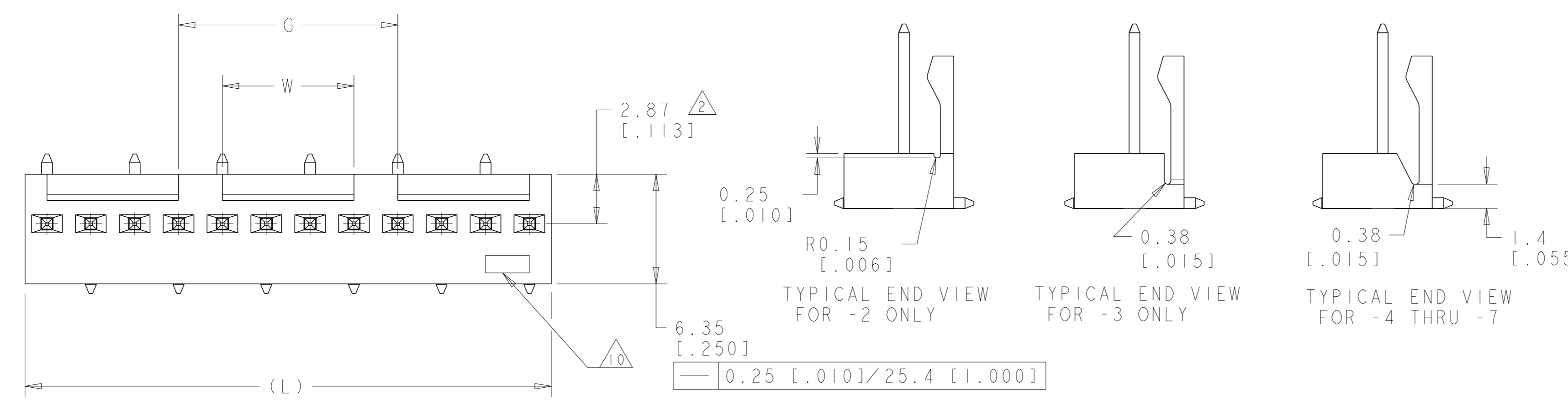

- 1. POST WITHSTAND 13 NEWTONS (3 LBS) MIN AXIAL FORCE IN DIRECTION SHOWN WITHOUT DISLODGING.
- 2. MEASURED AT -A-.
- 3. PARTS COMPLY WITH SOLDERABILITY SPEC 109-11-2.
- 4. MATERIAL:  
HOUSING: NYLON, 4/6, UL94V-0, HIGH TEMP. BLACK.  
POST - COPPER ALLOY (SEE TABLE FOR PLATING).
- 5. COORDINATE DIMENSION APPLIES FROM CENTER OF ACTUAL FEATURE.
- 6. POSTS TO BE MEASURED WHEN STRIP HELD FLAT.
- 7. PLATING: GOLD PLATE AREA, 0.00076 [0.00030] GOLD OR 0.00008 [0.00003] MIN GOLD FLASH OVER 0.00068 [0.00027] PALLADIUM NICKEL, PER TE CONNECTIVITY'S DISCRETION, ALL SIDES, OVER NICKEL UNDERPLATE, .00127 [0.00050] MIN, ALL SIDES AND ENTIRE LENGTH OF POST.
- 8. BRIGHT TIN/LEAD (93/7) PLATE AREA, 0.00381-0.00889 [0.000150-.000350] THICK, ALL FOUR SIDES, 3.56 [0.140] MIN.
- 9. DIMENSIONS IN BRACKETS ARE IN INCHES.
- 10. TE LOGO, UL, AND CSA TRADEMARKS TO APPEAR ON THIS SURFACE.
- 11. MATTE TIN PLATE AREA, 0.00381-0.00889 [0.000150-.000350] THICK, ALL FOUR SIDES, 3.56 [0.140] MIN.
- 12. OBSOLETE PARTS.

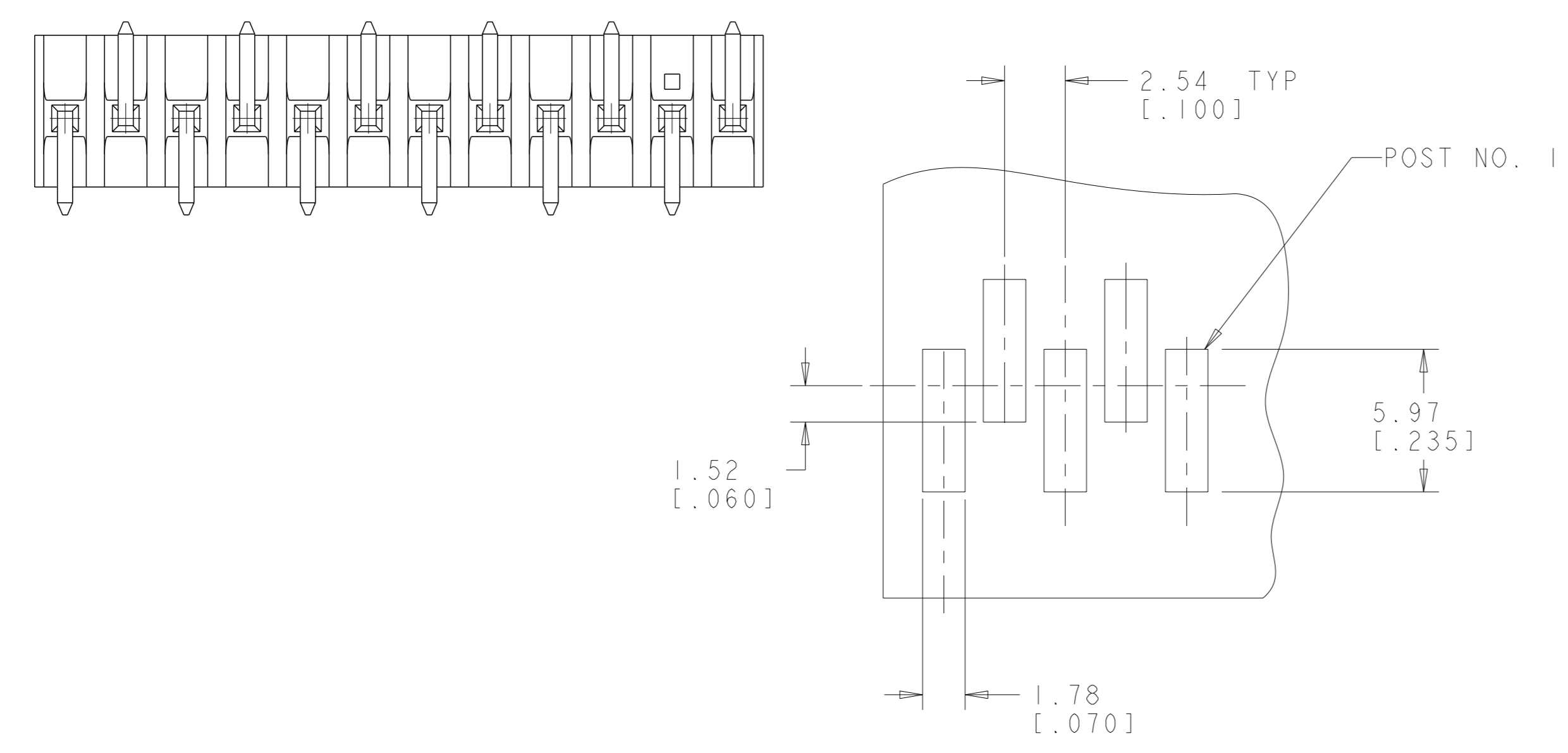
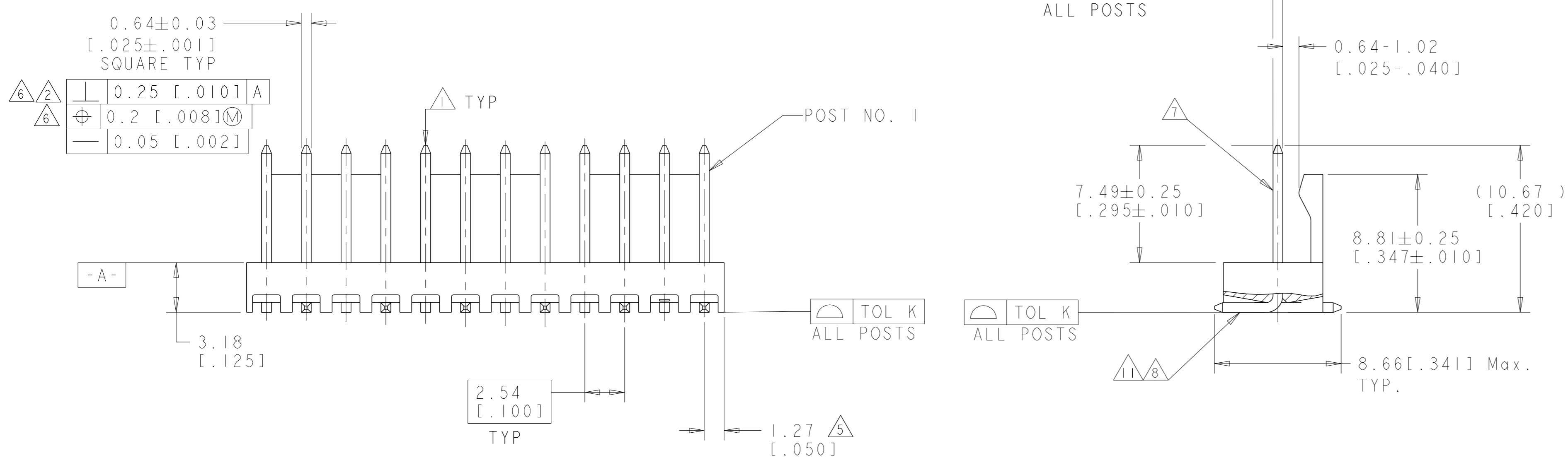

- 1. SUPERSEDED BY 4-647168-2
- 2. SUPERSEDED BY 4-647168-1
- 3. SUPERSEDED BY 4-647168-0
- 4. SUPERSEDED BY 3-647168-9
- 5. SUPERSEDED BY 3-647168-7
- 6. SUPERSEDED BY 3-647168-5
- 7. SUPERSEDED BY 3-647168-2

POST FINISH	TOL K	W	G	L	NO OF POSN	PART NO
7, 11	0.15 [0.006]	7.62 [0.300]	12.70 [0.500]	30.48 [1.200]	12	4-647168-2
	0.15 [0.006]	-	10.16 [0.400]	27.94 [1.100]	11	4-647168-1
	0.15 [0.006]	-	7.62 [0.300]	25.40 [1.000]	10	4-647168-0
	0.15 [0.006]	-	5.08 [0.200]	22.86 [0.900]	9	3-647168-9
	0.15 [0.006]	-	2.54 [0.100]	20.32 [0.800]	8	3-647168-8
	0.15 [0.006]	-	-	17.78 [0.700]	7	3-647168-7
	0.15 [0.006]	-	-	15.24 [0.600]	6	3-647168-6
	0.15 [0.006]	-	-	12.70 [0.500]	5	3-647168-5
	0.15 [0.006]	-	-	10.16 [0.400]	4	3-647168-4
7, 11, 8	0.15 [0.006]	-	-	7.62 [0.300]	3	3-647168-3
	0.15 [0.006]	-	-	5.08 [0.200]	2	3-647168-2
	0.20 [0.008]	12.70 [0.500]	20.32 [0.800]	38.10 [1.500]	15	1-647168-5
	0.15 [0.006]	7.62 [0.300]	12.70 [0.500]	30.48 [1.200]	12	1-647168-2
	0.15 [0.006]	-	10.16 [0.400]	27.94 [1.100]	11	1-647168-1
	0.15 [0.006]	-	7.62 [0.300]	25.40 [1.000]	10	1-647168-0
	0.15 [0.006]	-	5.08 [0.200]	22.86 [0.900]	9	647168-9
	0.15 [0.006]	-	2.54 [0.100]	20.32 [0.800]	8	647168-8
	0.15 [0.006]	-	-	17.78 [0.700]	7	647168-7

RECOMMENDED MOUNTING HOLE PATTERN FOR USE WITH 0.25 [0.010] THICK STENCIL

THIS DRAWING IS A CONTROLLED DOCUMENT. DIMENSIONS: mm [INCHES]. TOLERANCES UNLESS OTHERWISE SPECIFIED: 0 PLC ±, 1 PLC ±, 2 PLC ±, 3 PLC ±, 4 PLC ±. ANGLES: 45° 30'. MATERIAL: 4. CUSTOMER DRAWING. DATE: 14-NOV-2001. CHK: WHITAKER. D: BOSSI. APVD: BOSSI. PRODUCT SPEC. APPLICATION SPEC. SIZE: A1. CAGE CODE: 00779. DRAWING NO: 647168. SHEET 1 OF 1. REV R. TE Connectivity. A-100 HEADER ASSEMBLY, SURFACE MOUNT, FRICTION LOCK, .025 SQUARE STRAIGHT POST, .000030 GOLD. SCALE: 5:1.