

## Evaluation Board User Guide for the ADA4625-1 Low Noise, Fast Settling, Single Supply, RRO, JFET Op Amp

### FEATURES

- Full featured evaluation board for the [ADA4625-1](#)
- Enables quick prototyping
- User defined circuit configuration
- Edge mounted SMA connector provisions
- Easy connection to test equipment and other circuits

### EVALUATION KIT CONTENTS

- EVAL-ADA4625-1ARDZ evaluation board

### DOCUMENTS NEEDED

- [ADA4625-1 data sheet](#)

### GENERAL DESCRIPTION

This user guide describes the evaluation board for the [ADA4625-1](#) low noise, fast settling, single supply, rail-to-rail output (RRO), junction field effect transistor (JFET) op amp in an 8-lead small outline integrated circuit (SOIC) package with an exposed pad. The design of this evaluation board emphasizes simplicity and ease of use. This evaluation board is a 2-layer board that accommodates edge mounted SubMiniature version A (SMA) connectors on the inputs and outputs. The SMA connectors allow efficient connection to test equipment or other circuitry.

The evaluation board ground plane, components placement, and power supply bypassing are optimized for maximum circuit flexibility and performance. The exposed pad of the [ADA4625-1](#) is connected to the ground plane on the evaluation board to enhance thermal and noise performance. The evaluation board uses a combination of surface mount technology (SMT) component case sizes 0603 and 0805, with the exception of the bypass capacitors, Capacitor C3 and Capacitor C5, which have a maximum standard size of 1206. The evaluation board also features a variety of unpopulated resistor and capacitor pads, which provide the user with multiple choices and extensive flexibility for different application circuits and configurations, such as active loop filters, transimpedance amplifiers (TIAs), and charge amplifiers.

The [ADA4625-1](#) data sheet covers the specifications and details of the device operation and application circuit configurations and guidance. Consult the data sheet in conjunction with this user guide for a better understanding of the device operation, especially when powering up the evaluation board for the first time.

Figure 1 shows the top view of the evaluation board, and Figure 2 shows the bottom view.

### EVAL-ADA4625-1ARDZ PHOTOGRAPHS

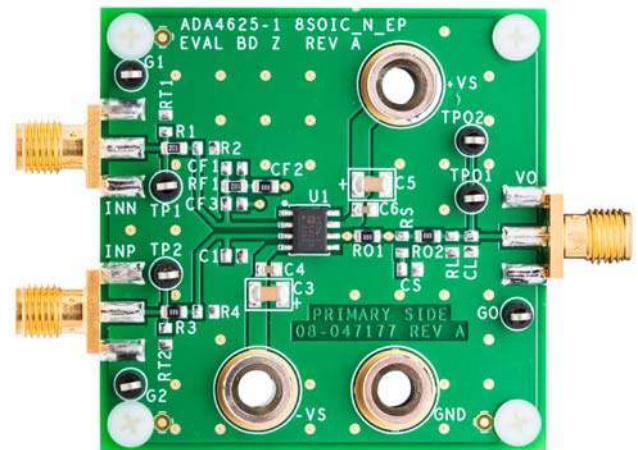

Figure 1. Top View

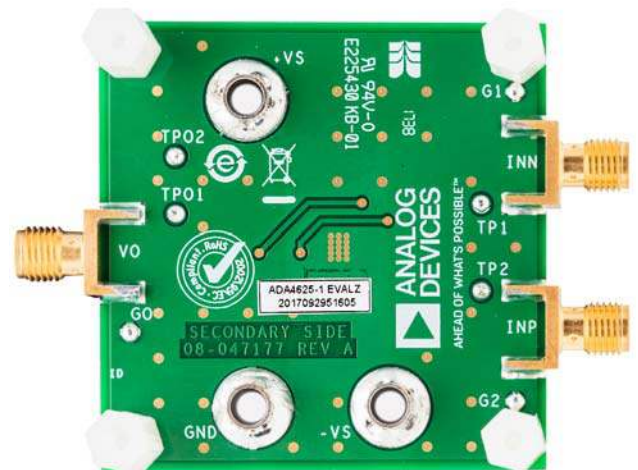

Figure 2. Bottom View

**TABLE OF CONTENTS**

Features .....	1	Additional Equipment Needed.....	3
Evaluation Kit Contents.....	1	Power Supply Configuration.....	3
Documents Needed.....	1	Initial Configuration.....	3
General Description .....	1	Power-Up Procedure.....	3
EVAL-ADA4625-1ARDZ Photographs.....	1	Evaluation Board Schematic and Artwork.....	4
Revision History .....	2	Evaluation Board Layout .....	5
Quick Start Operation.....	3	Ordering Information.....	6
Overview.....	3	Bill of Materials.....	6

**REVISION HISTORY**

10/2017—Revision 0: Initial Version

## QUICK START OPERATION

### OVERVIEW

This section outlines the basic configuration of the [ADA4625-1](#) evaluation board to test basic functionality of the device. For first time users, quick start operation is the best option to begin using the evaluation board immediately.

The input signal is applied to the edge mounted SMA type radio frequency (RF) connectors (INN and INP). The output signal is accessible via the edge mounted SMA connector (VO).

### ADDITIONAL EQUIPMENT NEEDED

- A signal generator
- A dual output dc power supply
- An oscilloscope with a bandwidth of at least 20 MHz
- Two SMA male to Bayonet Neill-Concelman (BNC) male cables
- Three banana plug to banana plug cables
- Optional 3 inch test hook jumper and SMA short

### POWER SUPPLY CONFIGURATION

The banana jacks, designated by +VS, -VS, and GND, power the evaluation board. Connect the dc power with correct polarity and voltage. Reverse polarity or overvoltage can permanently damage the evaluation board. Permissible supply voltages range from 5 V to 36 V. Higher voltages may damage the amplifier. Decoupling capacitors of 10  $\mu$ F and 0.1  $\mu$ F come preinstalled on the board for ready operation.

### INITIAL CONFIGURATION

To start the initial evaluation board configuration, use the following procedure:

1. Ensure that the power supply is off. Using the banana to banana cables, connect the positive supply, negative supply, and ground to the banana jacks +VS, -VS, and GND, respectively.
2. Connect the signal source to INP or Test Point TP2 and connect INN to ground.
3. Connect the output SMA connector (VO) to the oscilloscope using an SMA to BNC cable. Set the oscilloscope to 1 M $\Omega$  input impedance.

### POWER-UP PROCEDURE

After completing the initial configuration, use the following procedure to power up the board:

1. Set the V+ supply to 15 V and V- supply to -15 V.
2. Turn on the power supply. The typical supply current of the [ADA4625-1](#) is 4.0 mA. Current drawn from the power supply must not exceed 5 mA.
3. Configure the signal source to output a 1 kHz sine wave of 1 V p-p.
4. Enable the signal source. The oscilloscope must be able to measure a 10 V p-p sine wave at the output of the [ADA4625-1](#).

EVALUATION BOARD SCHEMATIC AND ARTWORK

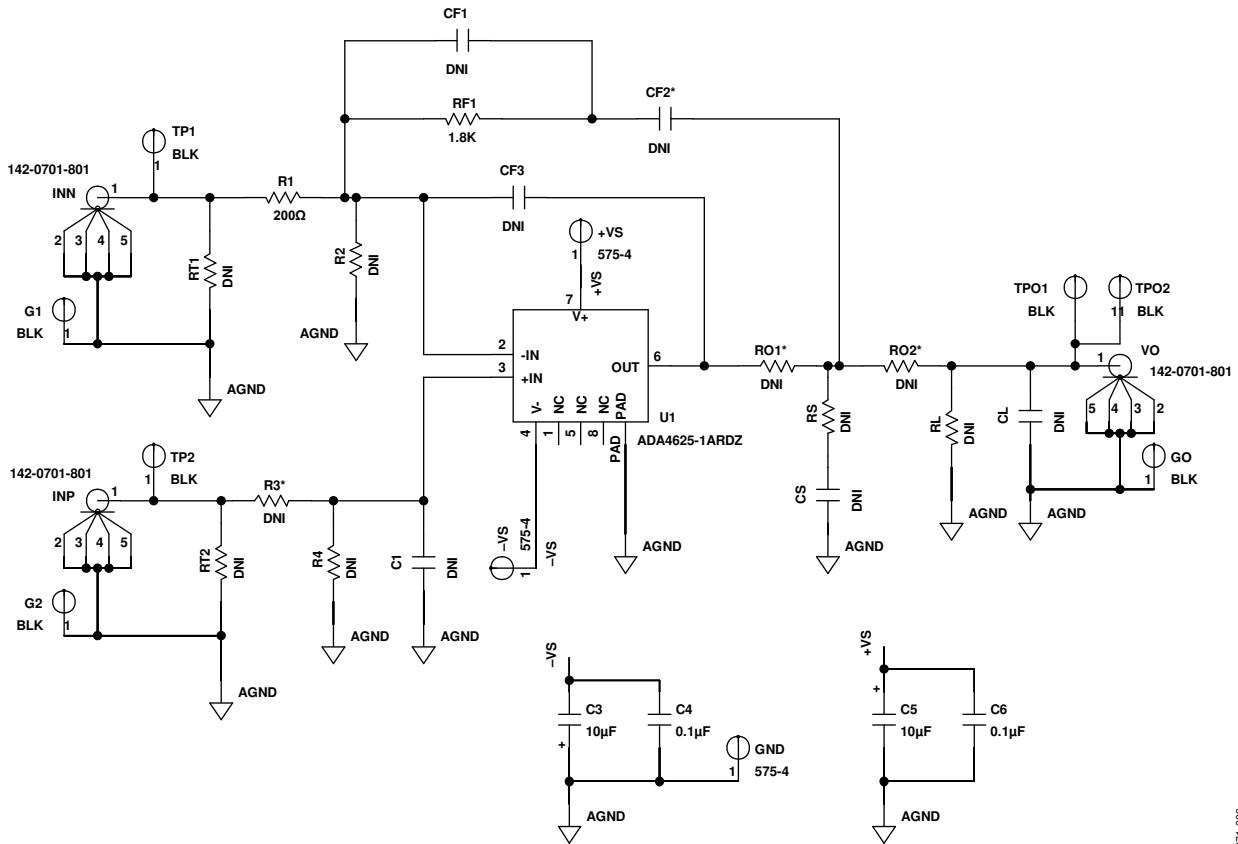

NOTE: \* THESE COMPONENTS ARE BY DEFAULT SHORTED WITH 0Ω RESISTOR.

Figure 3. Evaluation Board Schematic

16271-0103

EVALUATION BOARD LAYOUT

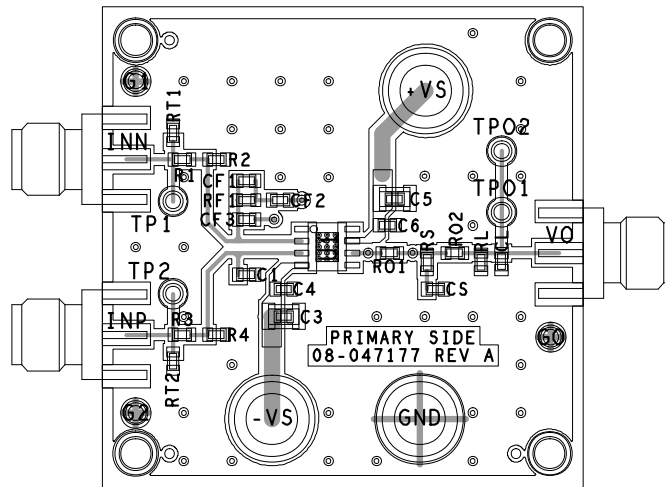

Figure 4. Component Side Layout

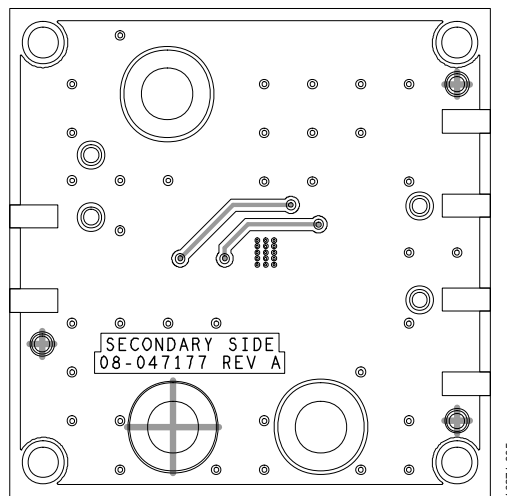

Figure 5. Circuit Side Layout

## ORDERING INFORMATION

## BILL OF MATERIALS

Table 1.

Qty	Reference Designator	Description	Supplier	Part Number
1	U1	8-lead SOIC_N_EP	Analog Devices, Inc.	ADA4625-1ARDZ
2	C3, C5	Ceramic capacitors, X7R, 0603, 0.1 $\mu$ F, 100 V	Murata Manufacturing Co.	GRM188R72A104
2	C4, C6	Ceramic capacitors, X5R, 1206, 10 $\mu$ F, 50 V	Murata Manufacturing Co.	GRM31CR61H106
1	R1	200 $\Omega$ resistor	Panasonic	ERA-6AEB201V
1	RF	1.82 k $\Omega$ resistor	Panasonic	ERA-6YEB182V
6	C1, CF1, CF2, CF3, CS, CL	User defined capacitors; CF2 is shorted with a 0 $\Omega$ resistor		
9	RT1, RT2, R2, R3, R4, RO1, RO2, RS, RL	User defined resistors; R3, RO1, and RO2 are shorted with 0 $\Omega$ resistors		
3	INN, INP, VO	Coax SMA end launch	Cinch Connectivity Solutions	142-0701-801
7	G1, G2, GO, TP1, TP2, TPO1, TPO2	Conn-PCB, test points	Components Corporation	TP-104-01-00
3	+VS, -VS, GND	Connectors, banana jack	Keystone Electronics	575-4

**ESD Caution**

**ESD (electrostatic discharge) sensitive device.** Charged devices and circuit boards can discharge without detection. Although this product features patented or proprietary protection circuitry, damage may occur on devices subjected to high energy ESD. Therefore, proper ESD precautions should be taken to avoid performance degradation or loss of functionality.

**Legal Terms and Conditions**

By using the evaluation board discussed herein (together with any tools, components documentation or support materials, the "Evaluation Board"), you are agreeing to be bound by the terms and conditions set forth below ("Agreement") unless you have purchased the Evaluation Board, in which case the Analog Devices Standard Terms and Conditions of Sale shall govern. Do not use the Evaluation Board until you have read and agreed to the Agreement. Your use of the Evaluation Board shall signify your acceptance of the Agreement. This Agreement is made by and between you ("Customer") and Analog Devices, Inc. ("ADI"), with its principal place of business at One Technology Way, Norwood, MA 02062, USA. Subject to the terms and conditions of the Agreement, ADI hereby grants to Customer a free, limited, personal, temporary, non-exclusive, non-sublicensable, non-transferable license to use the Evaluation Board FOR EVALUATION PURPOSES ONLY. Customer understands and agrees that the Evaluation Board is provided for the sole and exclusive purpose referenced above, and agrees not to use the Evaluation Board for any other purpose. Furthermore, the license granted is expressly made subject to the following additional limitations: Customer shall not (i) rent, lease, display, sell, transfer, assign, sublicense, or distribute the Evaluation Board; and (ii) permit any Third Party to access the Evaluation Board. As used herein, the term "Third Party" includes any entity other than ADI, Customer, their employees, affiliates and in-house consultants. The Evaluation Board is NOT sold to Customer; all rights not expressly granted herein, including ownership of the Evaluation Board, are reserved by ADI. CONFIDENTIALITY. This Agreement and the Evaluation Board shall all be considered the confidential and proprietary information of ADI. Customer may not disclose or transfer any portion of the Evaluation Board to any other party for any reason. Upon discontinuation of use of the Evaluation Board or termination of this Agreement, Customer agrees to promptly return the Evaluation Board to ADI. ADDITIONAL RESTRICTIONS. Customer may not disassemble, decompile or reverse engineer chips on the Evaluation Board. Customer shall inform ADI of any occurred damages or any modifications or alterations it makes to the Evaluation Board, including but not limited to soldering or any other activity that affects the material content of the Evaluation Board. Modifications to the Evaluation Board must comply with applicable law, including but not limited to the RoHS Directive. TERMINATION. ADI may terminate this Agreement at any time upon giving written notice to Customer. Customer agrees to return to ADI the Evaluation Board at that time. LIMITATION OF LIABILITY. THE EVALUATION BOARD PROVIDED HEREUNDER IS PROVIDED "AS IS" AND ADI MAKES NO WARRANTIES OR REPRESENTATIONS OF ANY KIND WITH RESPECT TO IT. ADI SPECIFICALLY DISCLAIMS ANY REPRESENTATIONS, ENDORSEMENTS, GUARANTEES, OR WARRANTIES, EXPRESS OR IMPLIED, RELATED TO THE EVALUATION BOARD INCLUDING, BUT NOT LIMITED TO, THE IMPLIED WARRANTY OF MERCHANTABILITY, TITLE, FITNESS FOR A PARTICULAR PURPOSE OR NON-INFRINGEMENT OF INTELLECTUAL PROPERTY RIGHTS. IN NO EVENT WILL ADI AND ITS LICENSORS BE LIABLE FOR ANY INCIDENTAL, SPECIAL, INDIRECT, OR CONSEQUENTIAL DAMAGES RESULTING FROM CUSTOMER'S POSSESSION OR USE OF THE EVALUATION BOARD, INCLUDING BUT NOT LIMITED TO LOST PROFITS, DELAY COSTS, LABOR COSTS OR LOSS OF GOODWILL. ADI'S TOTAL LIABILITY FROM ANY AND ALL CAUSES SHALL BE LIMITED TO THE AMOUNT OF ONE HUNDRED US DOLLARS (\$100.00). EXPORT. Customer agrees that it will not directly or indirectly export the Evaluation Board to another country, and that it will comply with all applicable United States federal laws and regulations relating to exports. GOVERNING LAW. This Agreement shall be governed by and construed in accordance with the substantive laws of the Commonwealth of Massachusetts (excluding conflict of law rules). Any legal action regarding this Agreement will be heard in the state or federal courts having jurisdiction in Suffolk County, Massachusetts, and Customer hereby submits to the personal jurisdiction and venue of such courts. The United Nations Convention on Contracts for the International Sale of Goods shall not apply to this Agreement and is expressly disclaimed.