

- ⚠ HOUSING: NYLON OR POLYESTER, FLAME RETARDANT 94V-0 RATED, GLASS FILLED, BLACK.
SHELLS: CARBON STEEL.
CONTACTS: BRASS.
BOARDLOCKS: COPPER ALLOY.
EYELETS: BRASS.
- ⚠ SHELLS: 2.54µm[.000100] MIN TIN OVER 1.27µm[.000050] MIN COPPER.
EYELETS: 5.08µm[.000200] MIN TIN OVER COPPER FLASH.
SCREWLOCKS AND INSERTS: CLEAR CHROMATE.
BOARDLOCKS AND CONTACTS: SEE TABLE.
- ⚠ GOLD FLASH ON THE MATING SURFACES, 2.54µm[.000100] MIN TIN OR TIN-LEAD PLATE ON THE SOLDER END, 1.27µm[.000050] MIN NICKEL UNDERPLATE ON THE ENTIRE CONTACT.
- ⚠ 0.76µm[.000030] MIN GOLD PLATE ON THE MATING SURFACES, 2.54µm[.000100] MIN TIN OR TIN-LEAD PLATE ON THE SOLDER END, 1.27µm[.000050] MIN NICKEL UNDERPLATE ON THE ENTIRE CONTACT
-OR-
GOLD FLASH OVER PALLADIUM-NICKEL PLATE, 0.76µm[.000030] MIN TOTAL ON THE MATING SURFACES, 2.54µm[.000100] MIN TIN OR TIN-LEAD PLATE ON THE SOLDER END, 1.27µm[.000050] MIN NICKEL UNDERPLATE ON THE ENTIRE CONTACT.
- ⚠ 5.08µm[.000200] MIN TIN-LEAD OVER 1.27µm[.000050] MIN NICKEL.
- ⚠ 5.08µm[.000200] MIN TIN OVER 1.27µm[.000050] MIN NICKEL.
- ⚠ OBSOLETE PARTS: OBSOLETE CIS STREAMLINING PER D.RENAUD/D.SINISI.

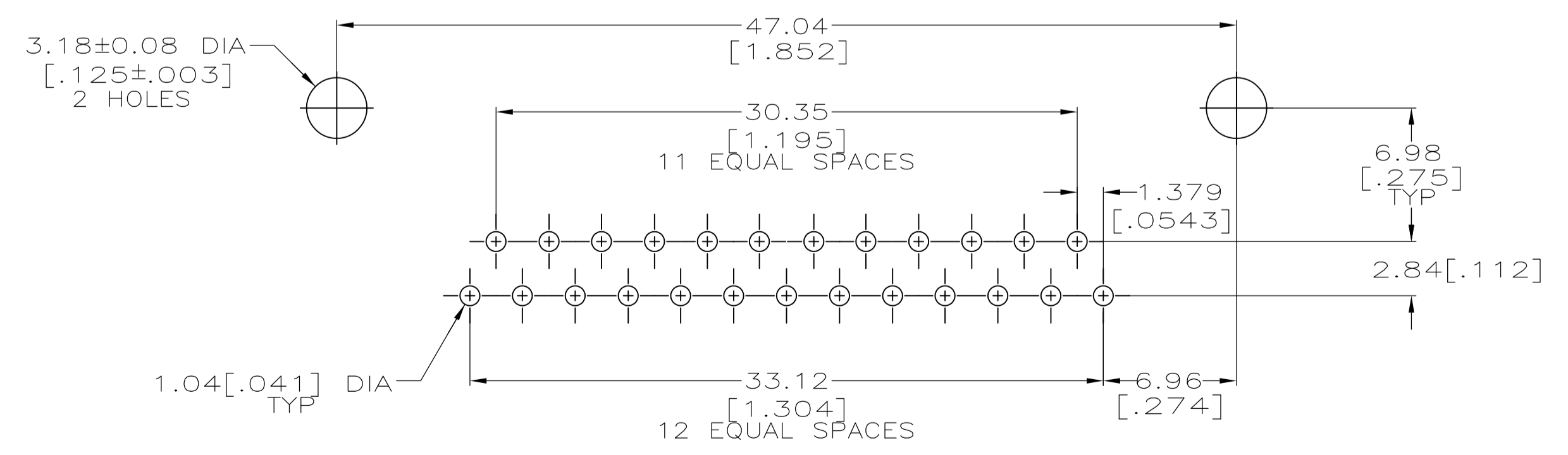
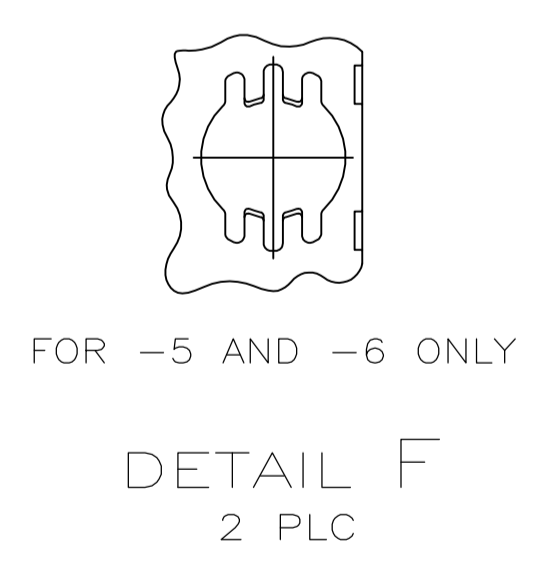
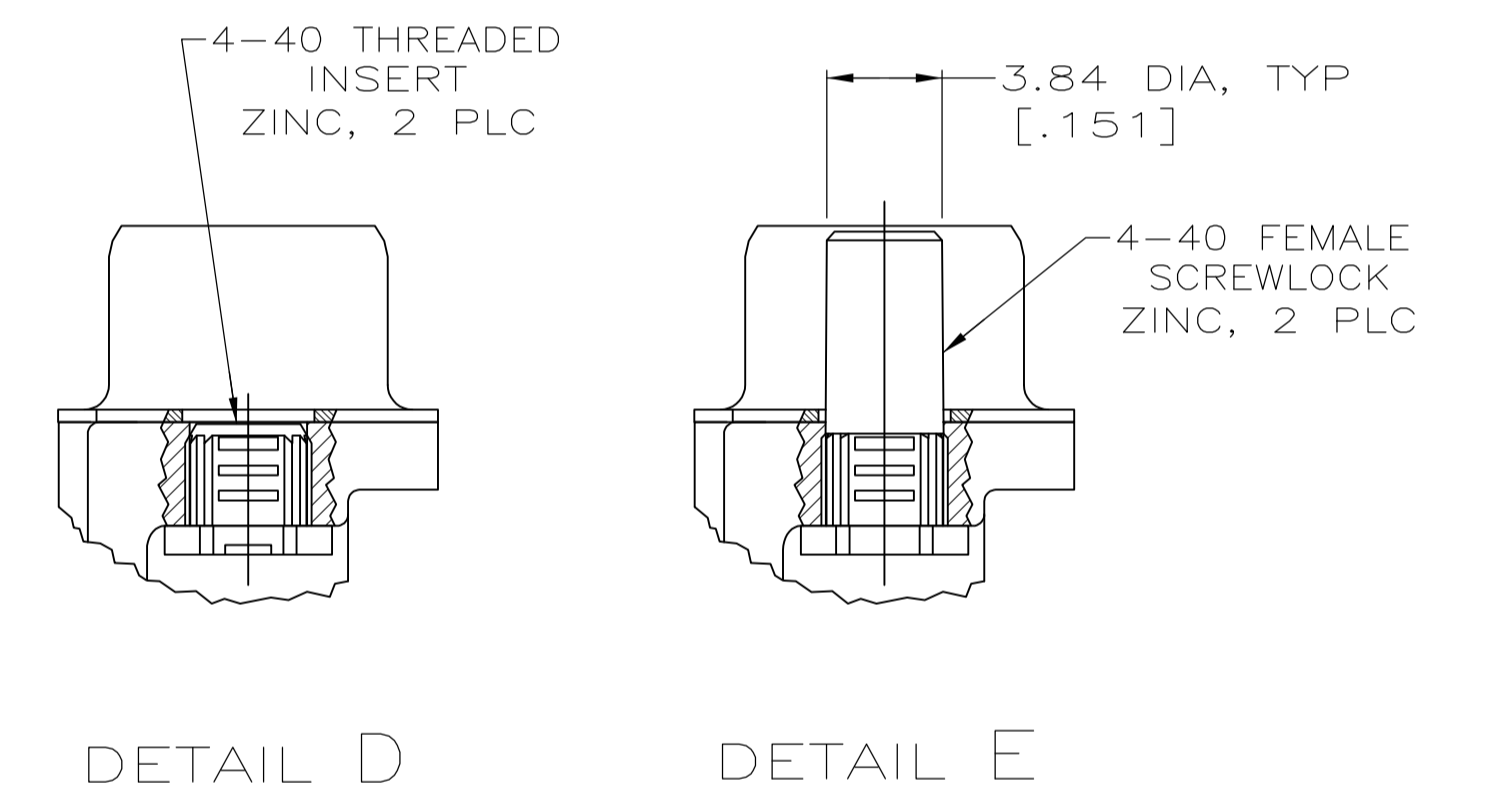
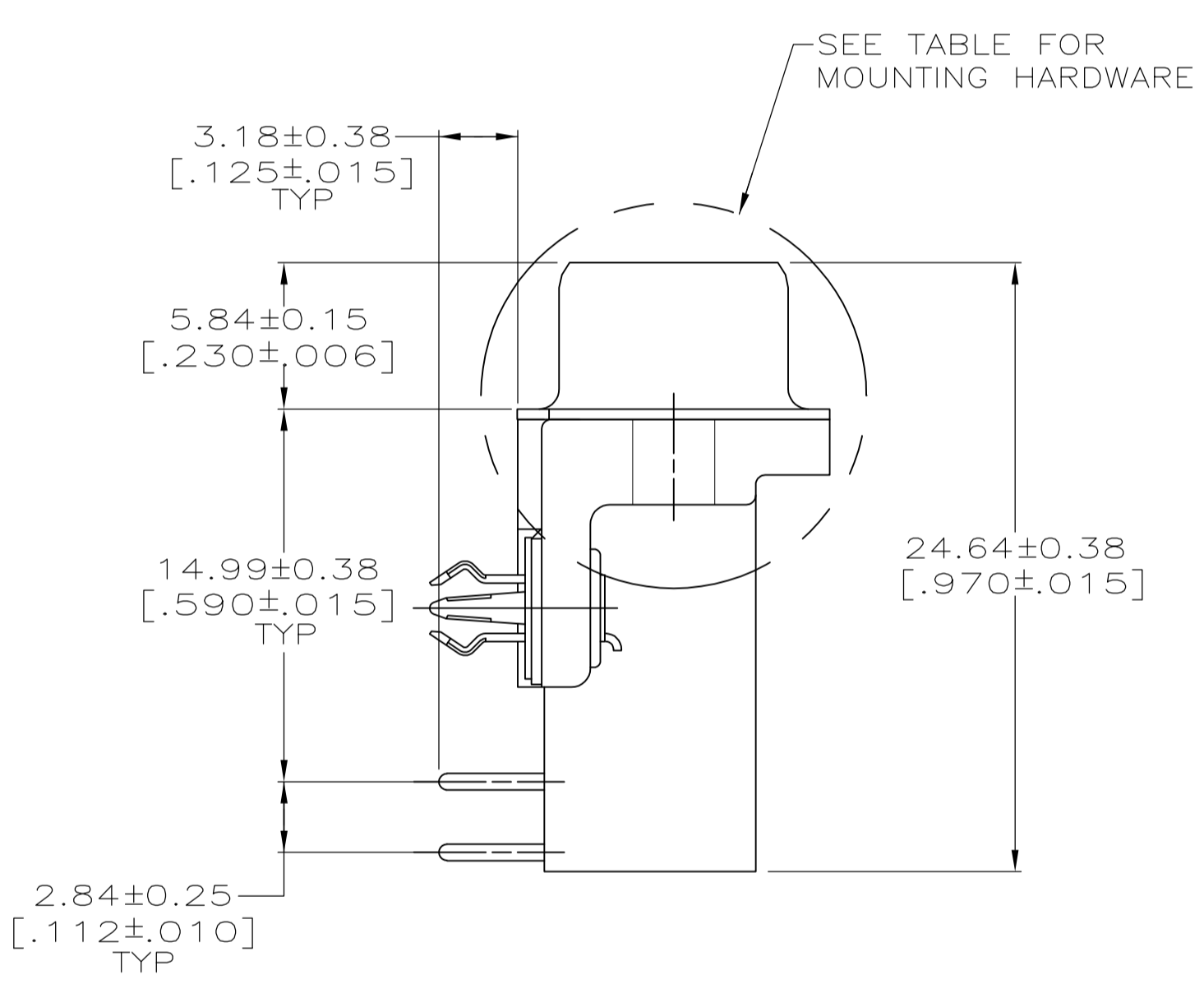
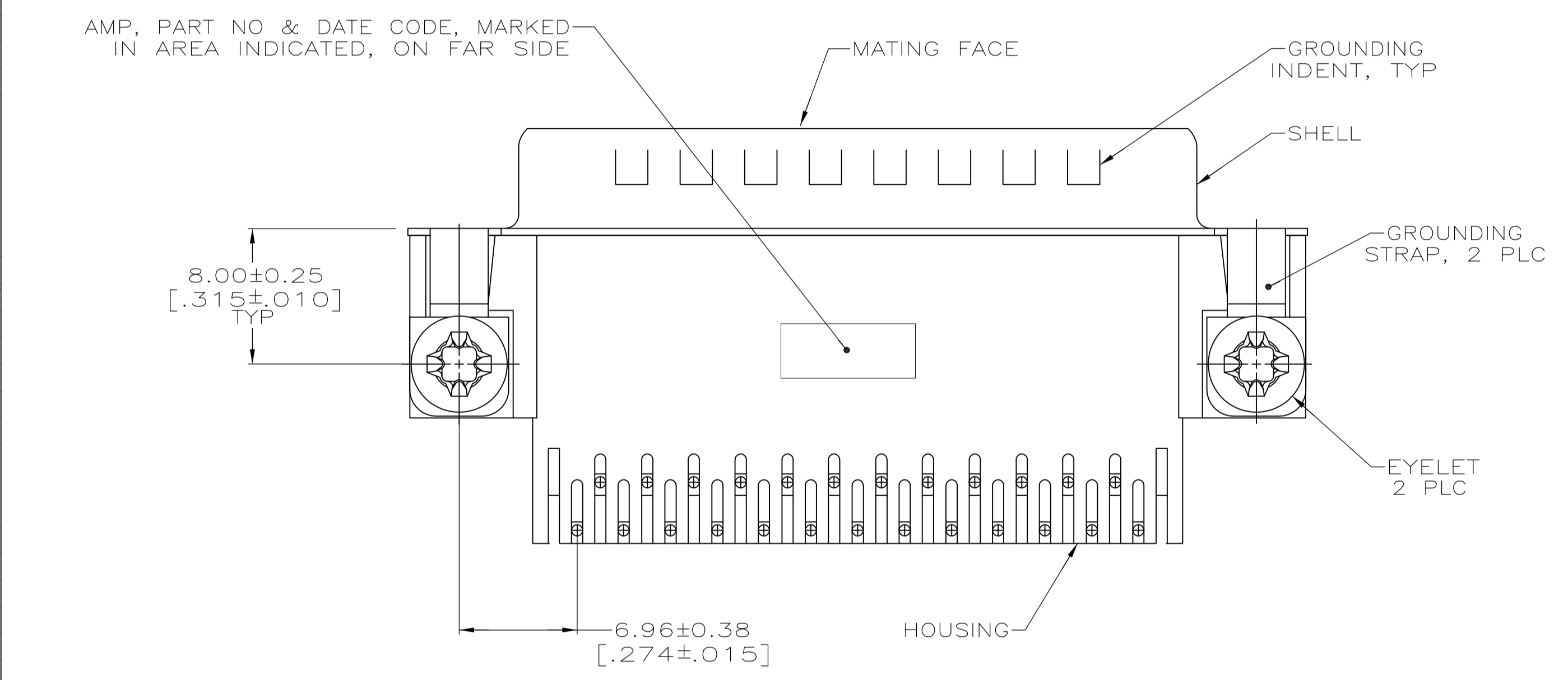

RECOMMENDED P.C. BOARD MOUNTING DIMENSIONS
P.C. BOARD THICKNESS: 1.57[.062]

⚠ OBSOLETE	SEE DETAIL D	⚠ 6	⚠ 4	6-747834-7
	SEE DETAIL E	⚠ 5	⚠ 4	747834-6
SUPSD BY 747834-4	SEE DETAIL E	⚠ 5	⚠ 3	747834-5
⚠ SUPERSEDED	SEE DETAIL D	⚠ 5	⚠ 4	747834-4
SUPSD BY 747834-4	SEE DETAIL D	⚠ 5	⚠ 3	747834-3
⚠ OBSOLETE	-	⚠ 5	⚠ 4	747834-2
⚠ OBSOLETE	-	⚠ 5	⚠ 3	747834-1
	MOUNTING HARDWARE	BOARDLOCK FINISH	CONTACT FINISH	PART NUMBER

THIS DRAWING IS A CONTROLLED DOCUMENT. DIMENSIONING AND TOLERANCING PER ASME Y14.5M-2009.

DIMENSIONS:	TOLERANCES UNLESS OTHERWISE SPECIFIED:	APVD	DATE	NAME
mm [INCHES]	0 PLC ± - 1 PLC ± - 2 PLC ± - 3 PLC ± 0.13[.005] 4 PLC ± - ANGLES ± ±	W.G. LENKER R. STONE M.D. GALLOWAY	16-NOV-89 05-FEB-90 06-FEB-90	PLUG ASSEMBLY, SIZE 3, 25 POSITION, RIGHT ANGLE, FRONT METAL SHELL, .590 SERIES, BOARDLOCKS, AMPLIMATE® HD-20
MATERIAL	FINISH	SIZE	CAGE CODE	DRAWING NO
⚠	⚠	114-40010	A1	00779
		WEIGHT	SCALE	SHEET
		-	4:1	1 OF 1

CUSTOMER DRAWING