

REV.	ECR/ECN No.	DESCRIPTION	DRAWN/DATE	CHECKED/DATE	APPROVED/DATE
F		UPDATE FRAME	Staven 2020-11-13	Staven 2020-11-13	Biao 2020-11-13
G	ECN2022112	UPDATE CPK SYMBOLS	Abner 2022-07-20	Staven 2022-07-20	Sam 2022-07-20

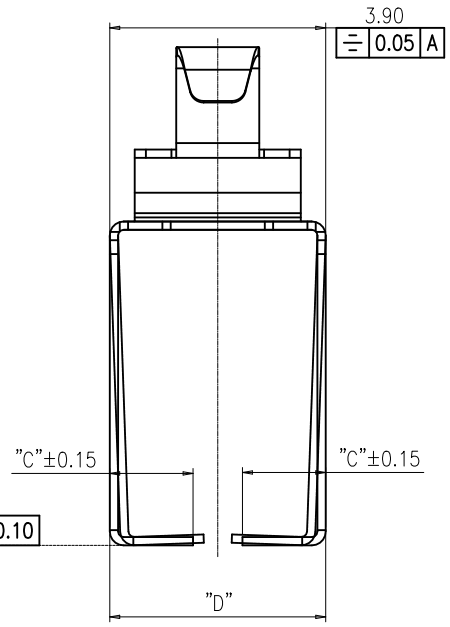
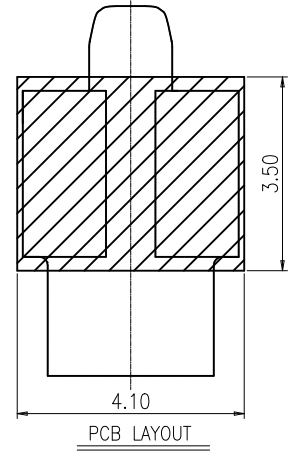
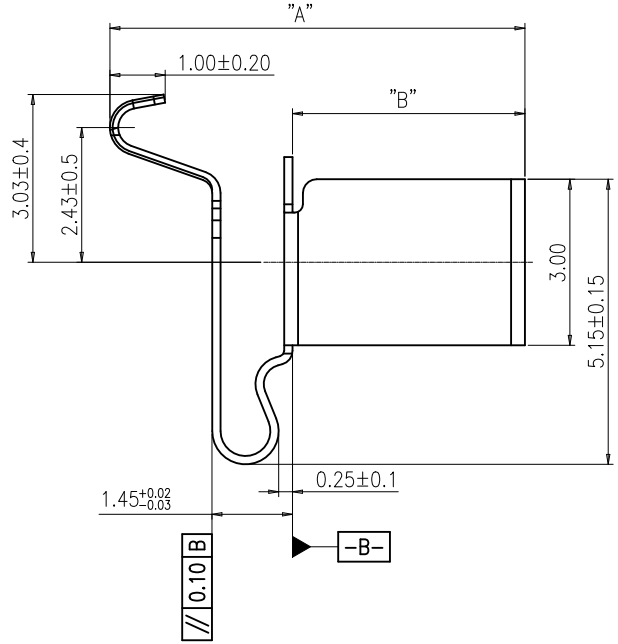
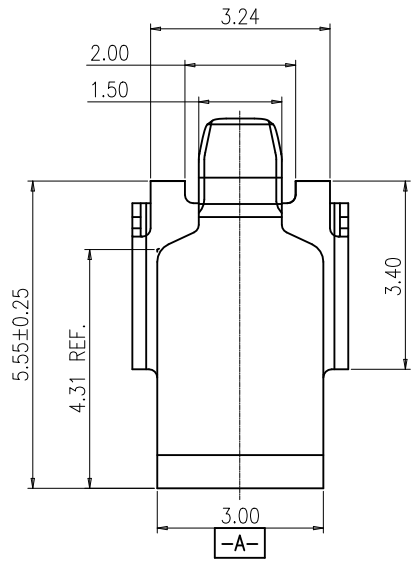

- NOTES:
- 1、 MATERIAL: SUS 304-H T=0.15mm;
 - 2、 ALLOW BURR 0.03mm Max.;
 - 3、 PLATING: Au 2u" SURFACE PLATING OVER CONTACT AREAS, Au 2u" SURFACE PLATING OVER SOLDER AREAS, Ni 40-120u" UNDER PLATING OVER ALL.
 - 4、 "▼" THE SYMBOL IS REPRESENTED AS CPK AND \bar{X} -R.

TABLE:

PART NUMBER	A	B	C	D
Z00D-4G7L1-11000	4.8 ^{+0.3} _{-0.05}	1.5 ^{+0.0} _{-0.3}	1.50	3.90 ⁺⁰ _{-0.20}
Z007-4G7L1-11000	5.2 ^{+0.3} _{-0.05}	1.9 ^{+0.0} _{-0.3}	1.05	3.90 ⁺⁰ _{-0.20}
Z00C-4G7L1-11000	7.5 ^{+0.3} _{-0.05}	4.2 ^{+0.0} _{-0.3}	1.50	3.90 ⁺⁰ _{-0.20}
Z00F-4G7L1-11000	9.0 ^{+0.3} _{-0.05}	5.7 ^{+0.0} _{-0.3}	0.80	3.90 ⁺⁰ _{-0.5}
Z00N-4G7L1-11000	6.3 ^{+0.3} _{-0.3}	3.0±0.15	1.50	3.90±0.15
Z00E-4G7L1-11000	4.0 ^{+0.3} _{-0.3}	0.7±0.15	1.50	3.90±0.15
Z00X-4G7L1-11000-E000	5.6 ^{+0.3} _{-0.3}	2.3±0.15	1.50	3.90±0.15

UNLESS OTHERWISE SPECIFIED TOLERANCES		ANGLE OF PROJECTION		 Amphenol Aorora Technology (Huizhou) Co.,Ltd
X.	±0.30	X.	± 5'	
X.X	±0.25	X.X	± 4'	
X.XX	±0.20	X.XX	± 3'	
X.XXX	±0.15	X.XXX	± 2'	
LINEAR DIMS		ANGLES DIMS		
DWG NO.:	A-S0198			TITLE: SPRING SIZE: A4 PART NUMBER: SEE TABLE REV. G
MATERIAL	SEE NOTES			
FINISHED	SEE NOTES			SCALE: 1:1 UNIT: mm SHEET 1 OF 1

This document is the property of and embodies CONFIDENTIAL and PROPRIETARY information of AOR. No part of the information shown on this document may be used in any way or disclosed to others without the written consent of AOR. © 2019 AOR



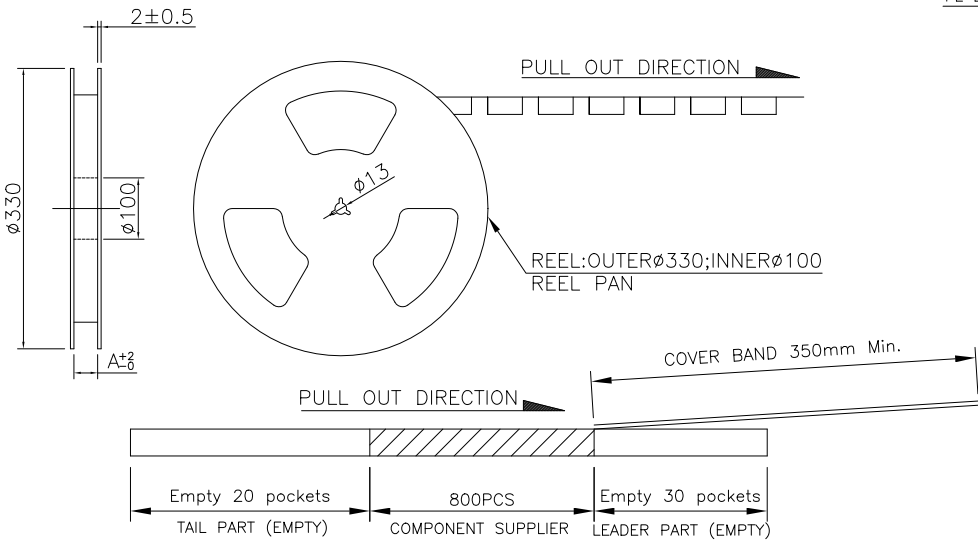
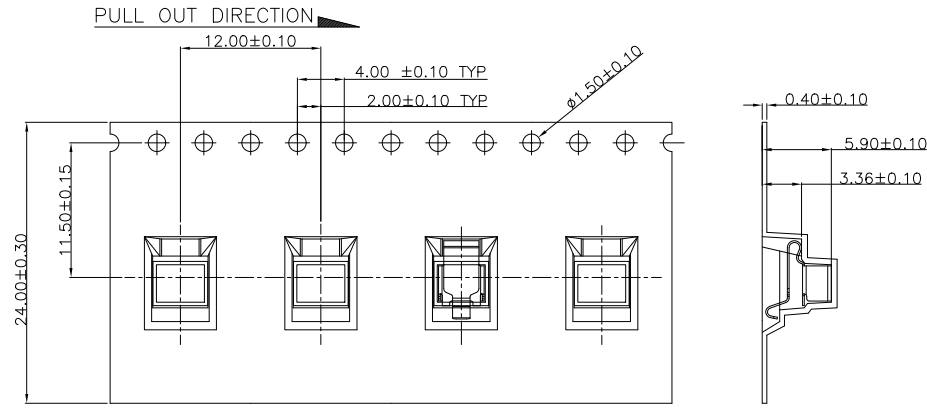

REV.	ECR/ECN No.	DESCRIPTION	DRAWN/DATE	CHECKED/DATE	APPROVED/DATE
A		NEW RELEASE	May 2016-04-11	Qi Han 2016-04-11	Hongkui Liu 2016-04-11
B	ECN2022112	UPDATE FRAME	Abner 2022-07-20	Staven 2022-07-20	Sam 2022-07-20

- NOTES:
- MATERIAL:
 - CARRY TAPE:HIPS,T=0.40mm, COLOR:TRANSPARENT.
 - REEL:HIPS,BLUE.
 - SHIM:PET,CLEAR.
 - PRIMARY PACKING:800PCS/REEL.
 - SECONDARY PACKING:10 REELS/CARTON ("TOTAL"=10*800/CARTON).
 - PEELING RESISTANCE: 0.1N~0.9N(10~90gf);
PEELING ANGLE: 165°~180°;
PEELING SPEED: 300mm/minutes.

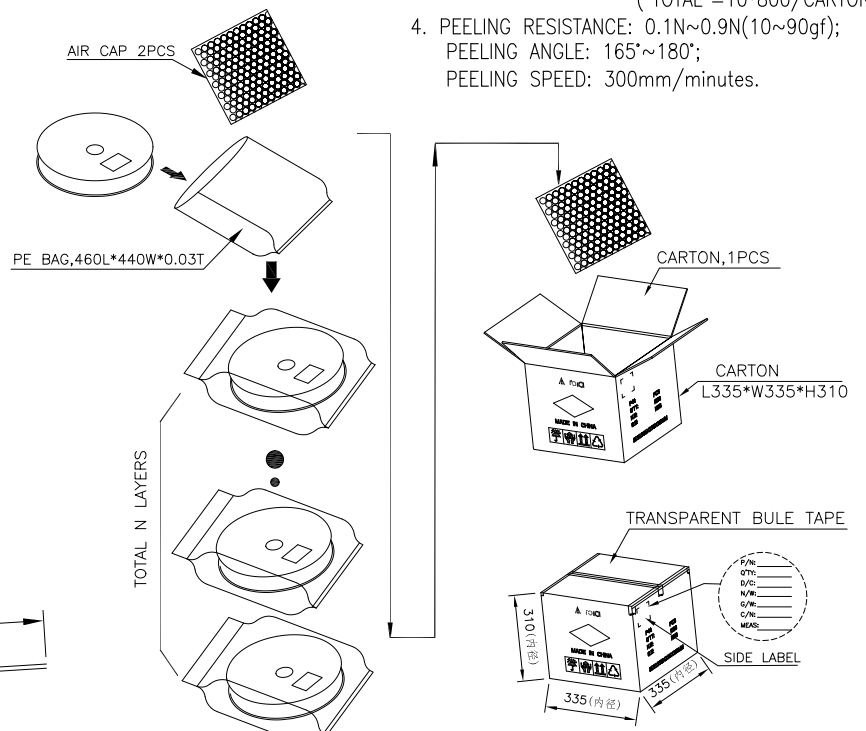

UNLESS OTHERWISE SPECIFIED TOLERANCES				ANGLE OF PROJECTION		Amphenol AORORA	
X.	±0.15	X. °	± 1'			Amphenol Aorora Technology (Huizhou) Co.,Ltd	
X.X	±0.16	X.X °	± 0.5'				
X.XX	±0.05	X.XX °	± 0.5'	DOC TYPE		TITLE:	
X.XXX	±0.03	X.XXX °	± 1'	PACKING DWG.		DRAWN DATE	
LINEAR DIMS		ANGLES DIMS		DESIGN DATE		PART NUMBER:	
DWG NO.: A-H0172				CHECKED DATE		A4	
MATERIAL		SEE NOTES		APPROVED DATE		SCALE	
FINISHED		SEE NOTES		DATE		UNIT : mm	
						SHEET 1 OF 1	