

## 100mA Charge Pump Voltage Converter with Shutdown

### Features:

- Optional High-Frequency Operation Allows Use of Small Capacitors
- Low Operating Current (FC = Open):
  - 50  $\mu$ A
- High Output Current (100 mA)
- Converts a 2.4V to 5.5V Input Voltage to a Corresponding Negative Output Voltage (Inverter mode)
- Uses Only 2 Capacitors; No Inductors Required
- Selectable Oscillator Frequency:
  - 10 kHz to 200 kHz
- Power-Saving Shutdown Input
- Available in 8-Pin MSOP, 8-Pin PDIP and 8-Pin Small Outline (SOIC) Packages

### Applications:

- Laptop Computers
- Medical Instruments
- Disk Drives
- $\mu$ P-Based Controllers
- Process Instrumentation

### Device Selection Table

Part Number	Package	Operating Temp. Range
TC1121COA	8-Pin SOIC	0°C to +70°C
TC1121CPA	8-Pin PDIP	0°C to +70°C
TC1121CUA	8-Pin MSOP	0°C to +70°C
TC1121EOA	8-Pin SOIC	-40°C to +85°C
TC1121EPA	8-Pin PDIP	-40°C to +85°C
TC1121EUA	8-Pin MSOP	-40°C to +85°C

### Package Type

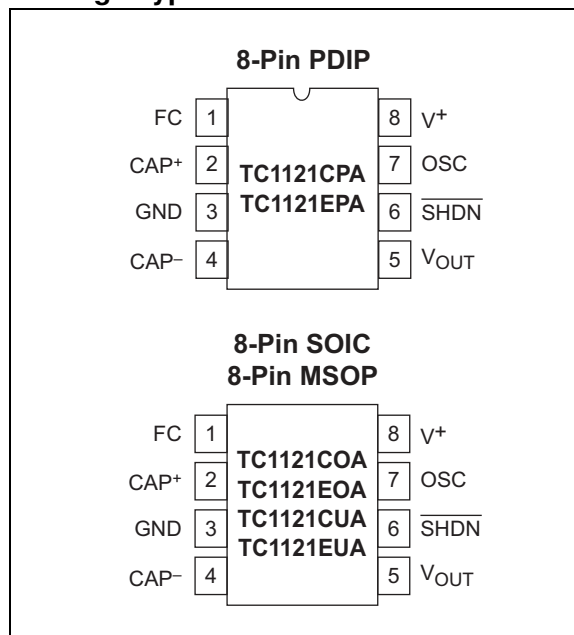

### General Description:

The TC1121 is a charge pump converter with 100 mA output current capability. It converts a 2.4V to 5.5V input to a corresponding negative output voltage. As with all charge pump converters, the TC1121 uses no inductors saving cost, size and EMI.

An on-board oscillator operates at a typical frequency of 10 kHz (at V<sup>+</sup> = 5V) when the frequency control input (FC) is left open. The oscillator frequency increases to 200 kHz when FC is connected to V<sup>+</sup>, allowing the use of smaller capacitors. Operation at sub-10 kHz frequencies results in lower quiescent current and is accomplished with the addition of an external capacitor from OSC (pin 7) to ground. The TC1121 also can be driven from an external clock connected OSC. Typical supply current at 10 kHz is 50  $\mu$ A, and falls to less than 1  $\mu$ A when the shutdown input is brought low, whether the internal or an external clock is used. The TC1121 is available in 8-pin SOIC, MSOP and PDIP packages.

# TC1121

## Functional Block Diagram

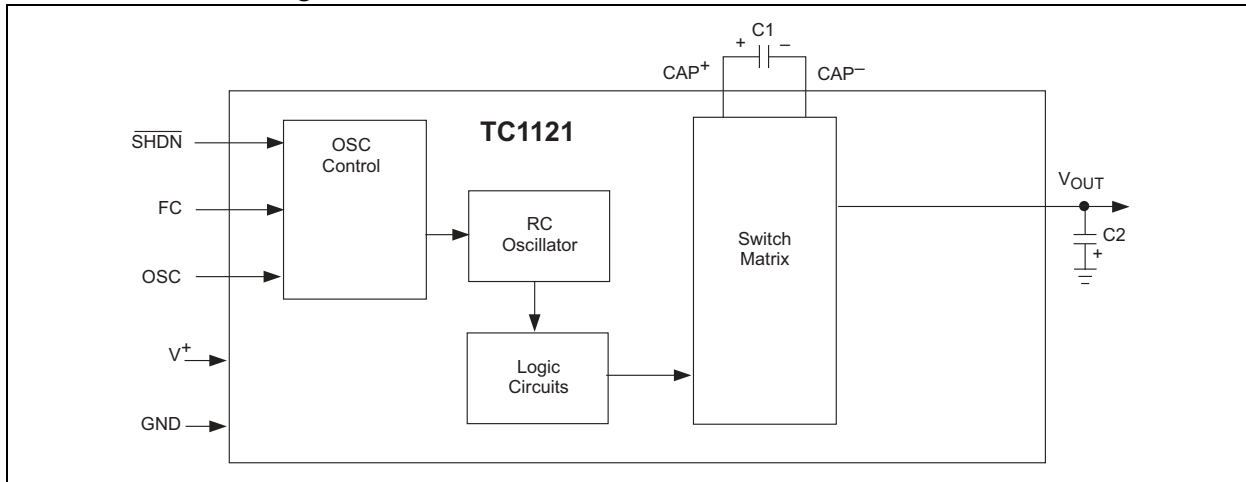

## 1.0 ELECTRICAL CHARACTERISTICS

### Absolute Maximum Ratings\*

Supply Voltage ( $V_{DD}$ ) .....	6V
OSC, FC, $\overline{\text{SHDN}}$ Input Voltage .....	-0.3V to ( $V^+ + 0.3V$ )
Output Short Circuit Duration .....	10 Sec.
Package Power Dissipation ( $T_A \leq 70^\circ\text{C}$ )	
8-Pin PDIP .....	730 mW
8-Pin SOIC .....	470 mW
8-Pin MSOP .....	333 mW
Operating Temperature Range	
C Suffix .....	0°C to +70°C
E Suffix .....	-40°C to +85°C
Storage Temperature Range .....	-65°C to +150°C

\*Stresses above those listed under "Absolute Maximum Ratings" may cause permanent damage to the device. These are stress ratings only and functional operation of the device at these or any other conditions above those indicated in the operation sections of the specifications is not implied. Exposure to Absolute Maximum Rating conditions for extended periods may affect device reliability.

## TC1121 ELECTRICAL SPECIFICATIONS

**Electrical Characteristics:**  $T_A = 0^\circ\text{C}$  to  $70^\circ\text{C}$  (C suffix),  $-40^\circ\text{C}$  to  $+85^\circ\text{C}$  (E suffix),  $V^+ = 5V \pm 10\%$   $C_{OSC} = \text{Open}$ ,  $C1, C2 = 10 \mu\text{F}$ ,  $\text{FC} = V^+$ ,  $\overline{\text{SHDN}} = V_{IH}$ , typical values are at  $T_A = 25^\circ\text{C}$  unless otherwise noted.

Symbol	Parameter	Min.	Typ.	Max.	Units	Test Conditions
$I_{DD}$	Active Supply Current	—	50	100	$\mu\text{A}$	$R_L = \text{Open}$ , $\text{FC} = \text{Open}$ or $\text{GND}$ $R_L = \text{Open}$ , $\text{FC} = V^+$
		—	0.6	1	$\text{mA}$	
$I_{\text{SHUTDOWN}}$	Shutdown Supply Current	—	0.2	1.0	$\mu\text{A}$	$\overline{\text{SHDN}} = 0V$
$V^+$	Supply Voltage	2.4	—	5.5	V	
$V_{IH}$	$\overline{\text{SHDN}}$ Input Logic High	$V_{DD} \times 0.8$	—	—	V	
$V_{IL}$	$\overline{\text{SHDN}}$ Input Logic Low	—	—	0.4	V	
$I_{IN}$	Input Leakage Current	-1	—	1	$\mu\text{A}$	$\overline{\text{SHDN}}$ , OSC FC pin
		-4	—	4		
$R_{OUT}$	Output Source Resistance	—	12	20	$\Omega$	$I_{OUT} = 60 \text{ mA}$
$I_{OUT}$	Output Current	60	100	—	$\text{mA}$	$V_{OUT} = \text{more negative than } -3.75V$
$F_{OSC}$	Oscillator Frequency	5	10	—	$\text{kHz}$	Pin 7 Open, Pin 1 Open or $\text{GND}$ $\overline{\text{SHDN}} = V_{IH}$ , Pin 1 = $V^+$
		100	200	—		
$P_{EFF}$	Power Efficiency	—	—	—	%	FC = $\text{GND}$ for all $R_L = 2k$ between $V^+$ and $V_{OUT}$ $R_L = 1k\Omega$ between $V_{OUT}$ and $\text{GND}$ $I_L = 60 \text{ mA}$ to $\text{GND}$
		93	97	—		
		94	97	—		
		—	92	—		
$V_{EFF}$	Voltage Conversion Efficiency	99	99.9	—	%	$R_L = \text{Open}$

**Note 1:** Connecting any input terminal to voltages greater than  $V^+$  or less than  $\text{GND}$  may cause destructive latch-up. It is recommended that no inputs from sources operating from external supplies be applied prior to "power up" of the TC1121.

# TC1121

---

## 2.0 PIN DESCRIPTIONS

The descriptions of the pins are listed in Table 2-1.

**TABLE 2-1: PIN FUNCTION TABLE**

Pin No. (8-Pin MSOP, PDIP, SOIC)	Symbol	Description
1	FC	Frequency control for internal oscillator, FC = open, $F_{OSC} = 10 \text{ kHz typ}$ ; FC = $V^+$ , $F_{OSC} = 200 \text{ kHz typ}$ ; FC has no effect when OSC pin is driven externally.
2	CAP <sup>+</sup>	Charge-pump capacitor, positive terminal.
3	GND	Power-supply ground input.
4	CAP <sup>-</sup>	Charge-pump capacitor, negative terminal.
5	OUT	Output, negative voltage.
6	$\overline{\text{SHDN}}$	Shutdown.
7	OSC	Oscillator control input. An external capacitor can be added to slow the oscillator. Take care to minimize stray capacitance. An external oscillator also may be connected to overdrive OSC.
8	$V^+$	Power-supply positive voltage input.

## 3.0 APPLICATIONS

### 3.1 Negative Voltage Converter

The TC1121 is typically used as a charge-pump voltage inverter. C1 and C2 are the only two external capacitors used in the operating circuit (Figure 3-1).

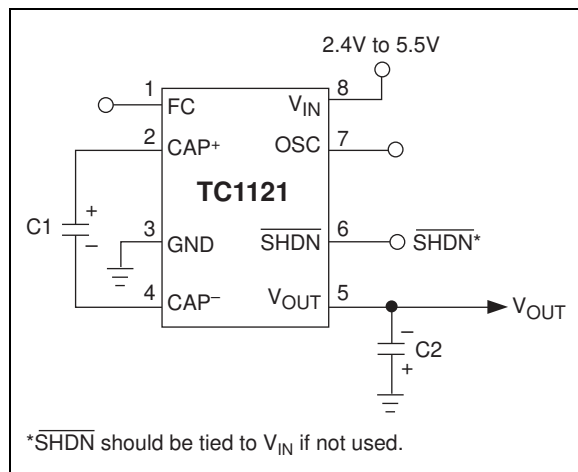

**FIGURE 3-1:** Charge Pump Inverter

The TC1121 is not sensitive to load current changes, although its output is not actively regulated. A typical output source resistance of 11.8Ω means that an input of +5V results in -5V output voltage under light load, and only decreases to -3.8V typ with a 100 mA load.

The supplied output current is from capacitor C2 during one-half the charge-pump cycle. This results in a peak-to-peak ripple of:

$$V_{\text{RIPPLE}} = I_{\text{OUT}}/2(f_{\text{PUMP}})(C2) + I_{\text{OUT}}(\text{ESR}_{C2})$$

Where  $f_{\text{PUMP}}$  is 5 kHz (one half the nominal 10 kHz oscillator frequency), and  $C2 = 150 \mu\text{F}$  with an ESR of 0.2Ω, ripple is about 90 mV with a 100 mA load current. If C2 is raised to 390 μF, the ripple drops to 45 mV.

### 3.2 Changing Oscillator Frequency

The TC1121's clock frequency is controlled by four modes:

**TABLE 3-1: OSCILLATOR FREQUENCY MODES**

FC	OSC	Oscillator Frequency
Open	Open	10 kHz
FC = V <sup>+</sup>	Open	200 kHz
Open or FC = V <sup>+</sup>	External Capacitor	See Typical Operating Characteristics
Open	External Clock	External Clock Frequency

The oscillator runs at 10 kHz (typical) when FC and OSC are not connected. The oscillator frequency is lowered by connecting a capacitor between OSC and GND, but FC can still multiply the frequency by 20 times in this mode.

An external clock source that swings within 100 mV of V<sup>+</sup> and GND may overdrive OSC in the Inverter mode. OSC can be driven by any CMOS logic output. When OSC is overdriven, FC has no effect.

Note that the frequency of the signal appearing at CAP<sup>+</sup> and CAP<sup>-</sup> is half that of the oscillator. In addition, by lowering the oscillator frequency, the effective output resistance of the charge-pump increases. To compensate for this, the value of the charge-pump capacitors may be increased.

Because the 5 kHz output ripple frequency may be low enough to interfere with other circuitry, the oscillator frequency can be increased with the use of the FC pin or an external oscillator. The output ripple frequency is half the selected oscillator frequency. Although the TC1121's quiescent current will increase if the clock frequency is increased, it allows smaller capacitance values to be used for C1 and C2.

### 3.3 Capacitor Selection

In addition to load current, the following factors affect the TC1121 output voltage drop from its ideal value 1) output resistance, 2) pump (C1) and reservoir (C2) capacitor ESRs and 3) C1 and C2 capacitance.

The voltage drop is the load current times the output resistance. The loss in C2 is the load current times C2's ESR; C1's loss is larger because it handles currents greater than the load current during charge-pump operation. Therefore, the voltage drop due to C1 is about four times C1's ESR multiplied by the load current, and a low (or high) ESR capacitor has a greater impact on performance for C1 than for C2.

In general, as the TC1121's pump frequency increases, capacitance values needed to maintain comparable ripple and output resistance diminish proportionately.

# TC1121

## 3.4 Cascading Devices

To produce greater negative magnitudes of the initial supply voltage, the TC1121 may be cascaded (see Figure 3-2). Resulting output resistance is approximately equal to the sum of individual TC1121  $R_{OUT}$  values. The output voltage (where  $n$  is an integer representing the number of devices cascaded) is defined by  $V_{OUT} = -n(V_{IN})$ .

## 3.5 Paralleling Devices

To reduce output resistance, multiple TC1121s may be paralleled (see Figure 3-3). Each device needs a pump capacitor  $C1$ , but the reservoir capacitor  $C2$  serves all devices. The value of  $C2$  should be increased by a factor of  $n$  (the number of devices).

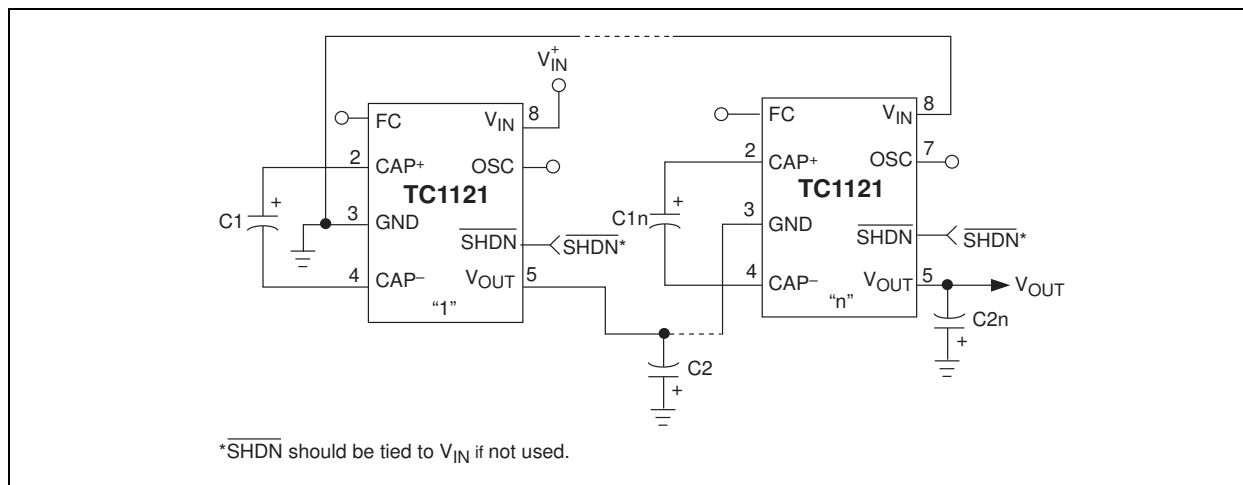

**FIGURE 3-2:** Cascading TC1121s to Increase Output Voltage

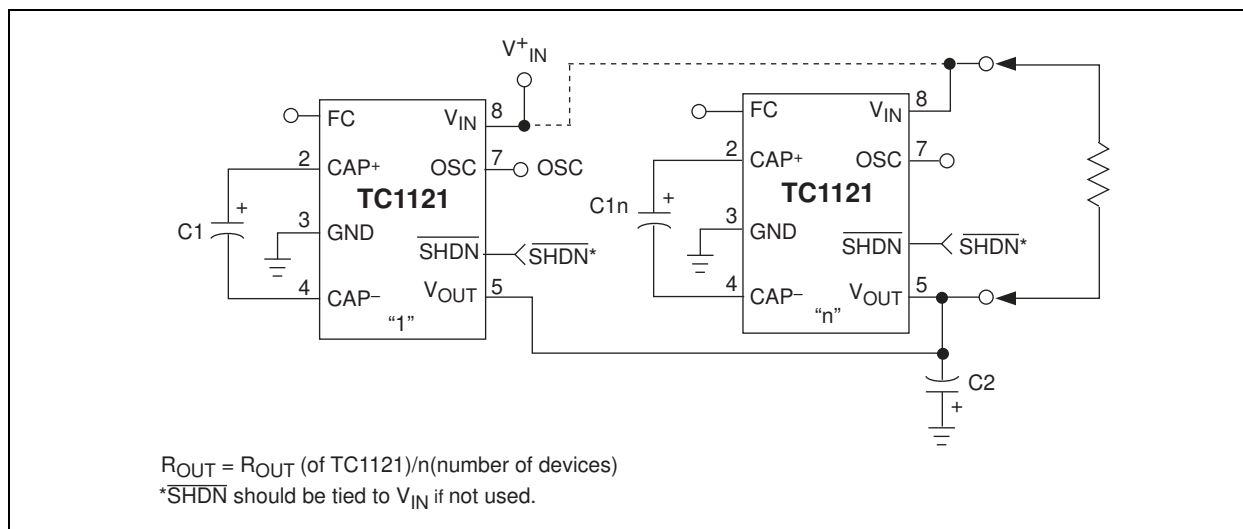

**FIGURE 3-3:** Paralleling TC1121s to Reduce Output Resistance

## 3.6 Combined Positive Supply Multiplication and Negative Voltage Conversion

Figure 3-4 shows this dual function circuit, in which capacitors C1 and C2 perform pump and reservoir functions to generate negative voltage. Capacitors C3 and C4 are the respective capacitors for multiplied positive voltage. This particular configuration leads to higher source impedances of the generated supplies due to the finite impedance of the common charge-pump driver.

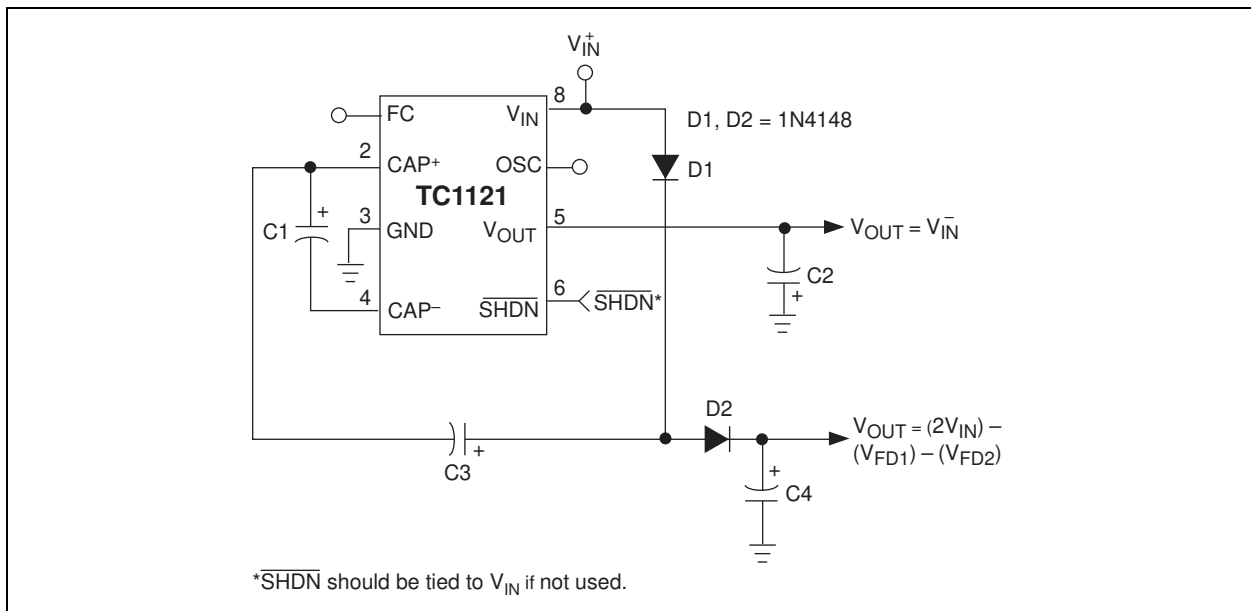

**FIGURE 3-4:** Combined Positive Multiplier and Negative Converter

## 4.0 PACKAGING INFORMATION

### 4.1 Package Marking Information

Package marking data not available at this time.

### 4.2 Taping Form

#### Component Taping Orientation for 8-Pin MSOP Devices

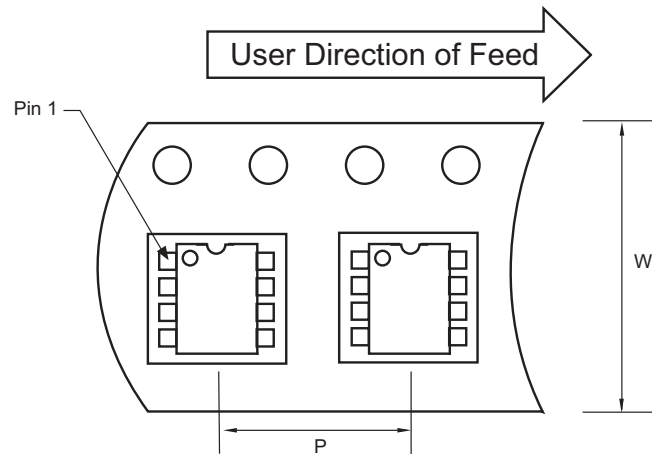

Standard Reel Component Orientation  
for 713 Suffix Device

Carrier Tape, Number of Components Per Reel and Reel Size

Package	Carrier Width (W)	Pitch (P)	Part Per Full Reel	Reel Size
8-Pin MSOP	12 mm	8 mm	2500	13 in

#### Component Taping Orientation for 8-Pin SOIC (Narrow) Devices

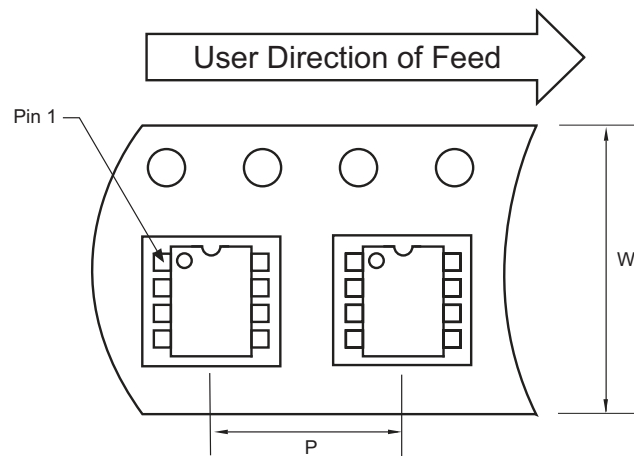

Standard Reel Component Orientation  
for 713 Suffix Device

Carrier Tape, Number of Components Per Reel and Reel Size

Package	Carrier Width (W)	Pitch (P)	Part Per Full Reel	Reel Size
8-Pin SOIC (N)	12 mm	8 mm	2500	13 in



## 4.3 Package Dimensions

### 8-Pin MSOP

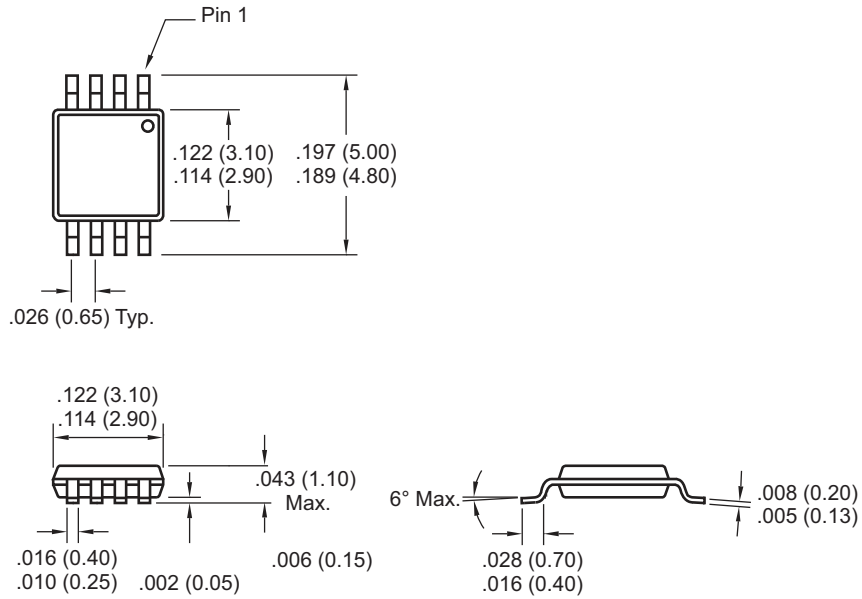

Dimensions: inches (mm)

### 8-Pin Plastic DIP

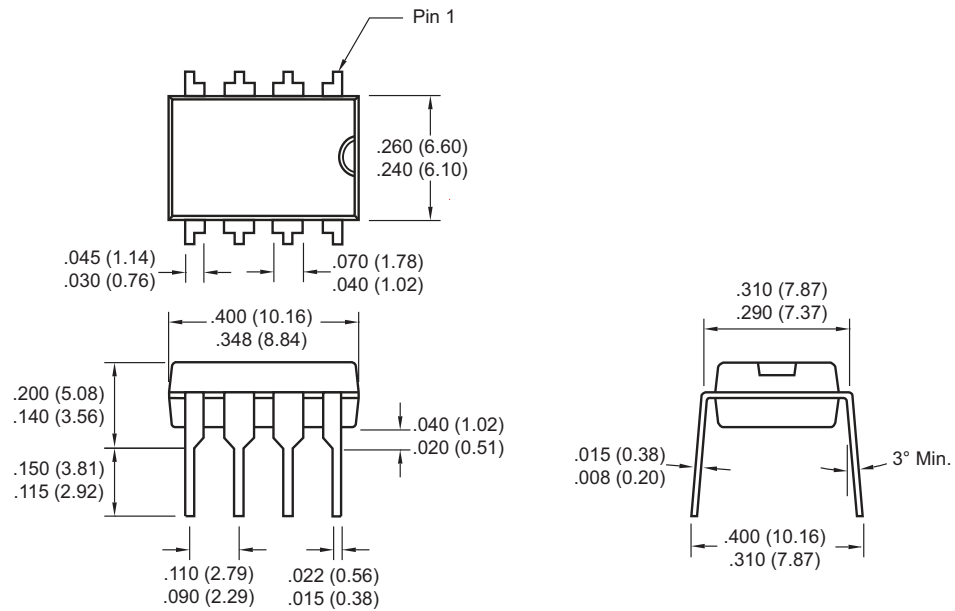

Dimensions: inches (mm)

# TC1121

## Package Dimensions (Continued)

### 8-Pin SOIC

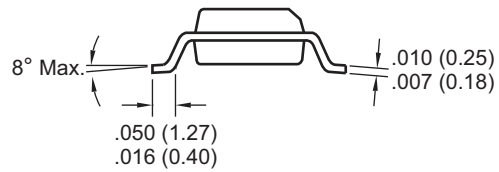
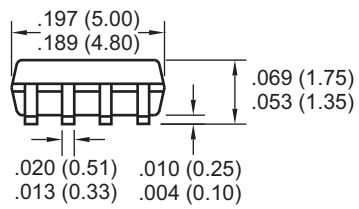
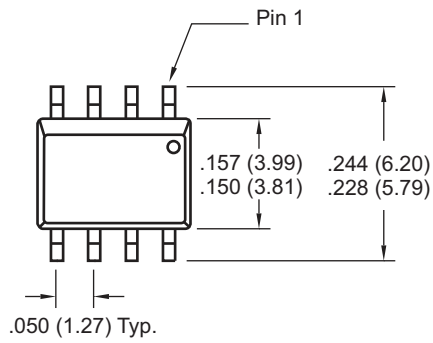

Dimensions: inches (mm)

## THE MICROCHIP WEB SITE

Microchip provides online support via our WWW site at [www.microchip.com](http://www.microchip.com). This web site is used as a means to make files and information easily available to customers. Accessible by using your favorite Internet browser, the web site contains the following information:

- **Product Support** – Data sheets and errata, application notes and sample programs, design resources, user's guides and hardware support documents, latest software releases and archived software
- **General Technical Support** – Frequently Asked Questions (FAQ), technical support requests, online discussion groups, Microchip consultant program member listing
- **Business of Microchip** – Product selector and ordering guides, latest Microchip press releases, listing of seminars and events, listings of Microchip sales offices, distributors and factory representatives

## CUSTOMER CHANGE NOTIFICATION SERVICE

Microchip's customer notification service helps keep customers current on Microchip products. Subscribers will receive e-mail notification whenever there are changes, updates, revisions or errata related to a specified product family or development tool of interest.

To register, access the Microchip web site at [www.microchip.com](http://www.microchip.com). Under "Support", click on "Customer Change Notification" and follow the registration instructions.

## CUSTOMER SUPPORT

Users of Microchip products can receive assistance through several channels:

- Distributor or Representative
- Local Sales Office
- Field Application Engineer (FAE)
- Technical Support

Customers should contact their distributor, representative or Field Application Engineer (FAE) for support. Local sales offices are also available to help customers. A listing of sales offices and locations is included in the back of this document.

**Technical support is available through the web site at: <http://microchip.com/support>**

# TC1121

---

NOTES:

---

---

**Note the following details of the code protection feature on Microchip devices:**

- Microchip products meet the specification contained in their particular Microchip Data Sheet.
- Microchip believes that its family of products is one of the most secure families of its kind on the market today, when used in the intended manner and under normal conditions.
- There are dishonest and possibly illegal methods used to breach the code protection feature. All of these methods, to our knowledge, require using the Microchip products in a manner outside the operating specifications contained in Microchip's Data Sheets. Most likely, the person doing so is engaged in theft of intellectual property.
- Microchip is willing to work with the customer who is concerned about the integrity of their code.
- Neither Microchip nor any other semiconductor manufacturer can guarantee the security of their code. Code protection does not mean that we are guaranteeing the product as “unbreakable.”

Code protection is constantly evolving. We at Microchip are committed to continuously improving the code protection features of our products. Attempts to break Microchip's code protection feature may be a violation of the Digital Millennium Copyright Act. If such acts allow unauthorized access to your software or other copyrighted work, you may have a right to sue for relief under that Act.

---

Information contained in this publication regarding device applications and the like is provided only for your convenience and may be superseded by updates. It is your responsibility to ensure that your application meets with your specifications. MICROCHIP MAKES NO REPRESENTATIONS OR WARRANTIES OF ANY KIND WHETHER EXPRESS OR IMPLIED, WRITTEN OR ORAL, STATUTORY OR OTHERWISE, RELATED TO THE INFORMATION, INCLUDING BUT NOT LIMITED TO ITS CONDITION, QUALITY, PERFORMANCE, MERCHANTABILITY OR FITNESS FOR PURPOSE. Microchip disclaims all liability arising from this information and its use. Use of Microchip devices in life support and/or safety applications is entirely at the buyer's risk, and the buyer agrees to defend, indemnify and hold harmless Microchip from any and all damages, claims, suits, or expenses resulting from such use. No licenses are conveyed, implicitly or otherwise, under any Microchip intellectual property rights.

#### **Trademarks**

The Microchip name and logo, the Microchip logo, dsPIC, FlashFlex, flexPWR, JukeBlox, KEELOQ, KEELOQ logo, Klear, LANCheck, MediaLB, MOST, MOST logo, MPLAB, OptoLyzer, PIC, PICSTART, PIC<sup>32</sup> logo, RightTouch, SpyNIC, SST, SST Logo, SuperFlash and UNI/O are registered trademarks of Microchip Technology Incorporated in the U.S.A. and other countries.

The Embedded Control Solutions Company and mTouch are registered trademarks of Microchip Technology Incorporated in the U.S.A.

Analog-for-the-Digital Age, BodyCom, chipKIT, chipKIT logo, CodeGuard, dsPICDEM, dsPICDEM.net, ECAN, In-Circuit Serial Programming, ICSP, Inter-Chip Connectivity, KlearNet, KlearNet logo, MiWi, MPASM, MPF, MPLAB Certified logo, MPLIB, MPLINK, MultiTRAK, NetDetach, Omniscient Code Generation, PICDEM, PICDEM.net, PICkit, PICtail, RightTouch logo, REAL ICE, SQI, Serial Quad I/O, Total Endurance, TSHARC, USBCheck, VariSense, ViewSpan, WiperLock, Wireless DNA, and ZENA are trademarks of Microchip Technology Incorporated in the U.S.A. and other countries.

SQTP is a service mark of Microchip Technology Incorporated in the U.S.A.

Silicon Storage Technology is a registered trademark of Microchip Technology Inc. in other countries.

GestIC is a registered trademarks of Microchip Technology Germany II GmbH & Co. KG, a subsidiary of Microchip Technology Inc., in other countries.

All other trademarks mentioned herein are property of their respective companies.

© 2006-2014, Microchip Technology Incorporated, Printed in the U.S.A., All Rights Reserved.

ISBN: 978-1-63276-410-2

**QUALITY MANAGEMENT SYSTEM**  
**CERTIFIED BY DNV**  
**== ISO/TS 16949 ==**

*Microchip received ISO/TS-16949:2009 certification for its worldwide headquarters, design and wafer fabrication facilities in Chandler and Tempe, Arizona; Gresham, Oregon and design centers in California and India. The Company's quality system processes and procedures are for its PIC® MCUs and dsPIC® DSCs, KEELOQ® code hopping devices, Serial EEPROMs, microperipherals, nonvolatile memory and analog products. In addition, Microchip's quality system for the design and manufacture of development systems is ISO 9001:2000 certified.*



# MICROCHIP

## Worldwide Sales and Service

### AMERICAS

**Corporate Office**  
2355 West Chandler Blvd.  
Chandler, AZ 85224-6199  
Tel: 480-792-7200  
Fax: 480-792-7277  
Technical Support:  
<http://www.microchip.com/support>  
Web Address:  
[www.microchip.com](http://www.microchip.com)

**Atlanta**  
Duluth, GA  
Tel: 678-957-9614  
Fax: 678-957-1455

**Austin, TX**  
Tel: 512-257-3370

**Boston**  
Westborough, MA  
Tel: 774-760-0087  
Fax: 774-760-0088

**Chicago**  
Itasca, IL  
Tel: 630-285-0071  
Fax: 630-285-0075

**Cleveland**  
Independence, OH  
Tel: 216-447-0464  
Fax: 216-447-0643

**Dallas**  
Addison, TX  
Tel: 972-818-7423  
Fax: 972-818-2924

**Detroit**  
Novi, MI  
Tel: 248-848-4000

**Houston, TX**  
Tel: 281-894-5983

**Indianapolis**  
Noblesville, IN  
Tel: 317-773-8323  
Fax: 317-773-5453

**Los Angeles**  
Mission Viejo, CA  
Tel: 949-462-9523  
Fax: 949-462-9608

**New York, NY**  
Tel: 631-435-6000

**San Jose, CA**  
Tel: 408-735-9110

**Canada - Toronto**  
Tel: 905-673-0699  
Fax: 905-673-6509

### ASIA/PACIFIC

**Asia Pacific Office**  
Suites 3707-14, 37th Floor  
Tower 6, The Gateway  
Harbour City, Kowloon  
Hong Kong  
Tel: 852-2943-5100  
Fax: 852-2401-3431

**Australia - Sydney**  
Tel: 61-2-9868-6733  
Fax: 61-2-9868-6755

**China - Beijing**  
Tel: 86-10-8569-7000  
Fax: 86-10-8528-2104

**China - Chengdu**  
Tel: 86-28-8665-5511  
Fax: 86-28-8665-7889

**China - Chongqing**  
Tel: 86-23-8980-9588  
Fax: 86-23-8980-9500

**China - Hangzhou**  
Tel: 86-571-8792-8115  
Fax: 86-571-8792-8116

**China - Hong Kong SAR**  
Tel: 852-2943-5100  
Fax: 852-2401-3431

**China - Nanjing**  
Tel: 86-25-8473-2460  
Fax: 86-25-8473-2470

**China - Qingdao**  
Tel: 86-532-8502-7355  
Fax: 86-532-8502-7205

**China - Shanghai**  
Tel: 86-21-5407-5533  
Fax: 86-21-5407-5066

**China - Shenyang**  
Tel: 86-24-2334-2829  
Fax: 86-24-2334-2393

**China - Shenzhen**  
Tel: 86-755-8864-2200  
Fax: 86-755-8203-1760

**China - Wuhan**  
Tel: 86-27-5980-5300  
Fax: 86-27-5980-5118

**China - Xian**  
Tel: 86-29-8833-7252  
Fax: 86-29-8833-7256

**China - Xiamen**  
Tel: 86-592-2388138  
Fax: 86-592-2388130

**China - Zhuhai**  
Tel: 86-756-3210040  
Fax: 86-756-3210049

### ASIA/PACIFIC

**India - Bangalore**  
Tel: 91-80-3090-4444  
Fax: 91-80-3090-4123

**India - New Delhi**  
Tel: 91-11-4160-8631  
Fax: 91-11-4160-8632

**India - Pune**  
Tel: 91-20-3019-1500

**Japan - Osaka**  
Tel: 81-6-6152-7160  
Fax: 81-6-6152-9310

**Japan - Tokyo**  
Tel: 81-3-6880-3770  
Fax: 81-3-6880-3771

**Korea - Daegu**  
Tel: 82-53-744-4301  
Fax: 82-53-744-4302

**Korea - Seoul**  
Tel: 82-2-554-7200  
Fax: 82-2-558-5932 or  
82-2-558-5934

**Malaysia - Kuala Lumpur**  
Tel: 60-3-6201-9857  
Fax: 60-3-6201-9859

**Malaysia - Penang**  
Tel: 60-4-227-8870  
Fax: 60-4-227-4068

**Philippines - Manila**  
Tel: 63-2-634-9065  
Fax: 63-2-634-9069

**Singapore**  
Tel: 65-6334-8870  
Fax: 65-6334-8850

**Taiwan - Hsin Chu**  
Tel: 886-3-5778-366  
Fax: 886-3-5770-955

**Taiwan - Kaohsiung**  
Tel: 886-7-213-7830

**Taiwan - Taipei**  
Tel: 886-2-2508-8600  
Fax: 886-2-2508-0102

**Thailand - Bangkok**  
Tel: 66-2-694-1351  
Fax: 66-2-694-1350

### EUROPE

**Austria - Wels**  
Tel: 43-7242-2244-39  
Fax: 43-7242-2244-393

**Denmark - Copenhagen**  
Tel: 45-4450-2828  
Fax: 45-4485-2829

**France - Paris**  
Tel: 33-1-69-53-63-20  
Fax: 33-1-69-30-90-79

**Germany - Dusseldorf**  
Tel: 49-2129-3766400

**Germany - Munich**  
Tel: 49-89-627-144-0  
Fax: 49-89-627-144-44

**Germany - Pforzheim**  
Tel: 49-7231-424750

**Italy - Milan**  
Tel: 39-0331-742611  
Fax: 39-0331-466781

**Italy - Venice**  
Tel: 39-049-7625286

**Netherlands - Drunen**  
Tel: 31-416-690399  
Fax: 31-416-690340

**Poland - Warsaw**  
Tel: 48-22-3325737

**Spain - Madrid**  
Tel: 34-91-708-08-90  
Fax: 34-91-708-08-91

**Sweden - Stockholm**  
Tel: 46-8-5090-4654

**UK - Wokingham**  
Tel: 44-118-921-5800  
Fax: 44-118-921-5820

03/25/14