

AGSM-SO₂-5

(Allsensing gas sensor module)



Homepage: <https://www.allsensing.com/> wiki: http://docs.k-allsensing.com/agsm:agsm_so2

Summary

AGSM can be easily applied to devices linked to the Internet of Things (IoT) and provides an easy way to monitor sensor values and environmental changes.

- AGSM completes gas calibration and transmits the sensor concentration value (PPB) data using UART communication.
- It is not suitable for applications requiring fast response time ($T_{90} < 30\text{sec}$) and is designed to be suitable for monitoring environmental changes for a long time.
- At least 30 minutes to 1 hour or more of sensor stabilization time is required.
- Applied to temperature compensation and gas sensor calibration algorithm.
- It can check the sensor signal value (raw data) output from the sensor driving circuit.
- AGSM product can be applied by interworking with Arduino and compatible products.
- It can be easily integrated into wireless gas detector, portable and network solutions that require small size, light weight, high performance and low power.
- AGSM is supplied with individual gas sensors for CO, H₂S, SO₂, NO₂ and O₃.
- Sensor Calibration
 - If the user has calibration gas and test environment, Zero calibration and Span Calibration can be performed using communication commands.
 - It is recommended to perform Span Calibration of the gas sensor every 6 months.
 - AGSM products are calibrated by using a small chamber of 400mL.

Product specification and connection method

1) Module Specifications

Performance Characteristics	
Detection Gas	SO ₂ (Sulfur Dioxide)
Operating Principle	Solid electrolyte electrochemical formula (3-electrode)
Measurement Range	0~5PPM
Low Detection Limit	0.1PPM (100PPB)
Resolution	0.001PPM (1PPB)
Accuracy	<5% @ Full Range
T90 response time	<150 sec
Communication output	UART (TTL 3.3V, 5.0V) 3.3VDC Power input: 3.3V TTL Level 5.0VDC Power input: 5.0V TTL Level
Expected Operating Life	> 5 years (10 years @ 25± 10C; 60 ± 30% RH)
Electrical Characteristic	
Operating Input Voltage Range	DC 3.3V ~ 5.0V
Operating Current and Power Consumption	(1 Sec period data transmission/reception power consumption) LED ON - Average: 1.13mA at 3.3VDC(3.7mW) - Max 1.17mA at 3.3VDC LED OFF - Average: 0.38mA at 3.3VDC(1.3mW) - Max 0.47mA at 3.3VDC
Dimension	Size: L X W X H (35 x 21.1 mm x 11.8mm), Height: 11.8mm (Sensor socket applied, standard product), 8mm (Sensor socket not applied, user request)
Environmental	
Operating Temperature	-20 to 40 °C
Operating Humidity Range	15 to 95%

Based on Standard Conditions	25 °C, 50% RH and 1 atm
------------------------------	-------------------------

Connect the product

1) Pin Connection

- Connector(default): Molex 53261, Yeonho 12505WR
- Pin header(option): 2.54 pitch (V:VCC, G:GND, R: RXD, T: TXD)

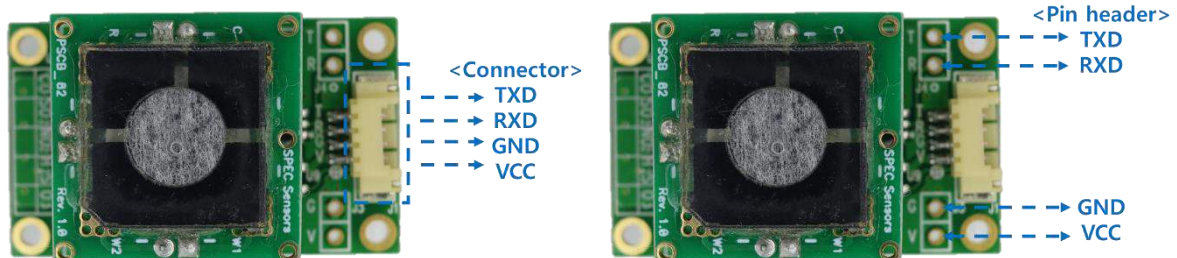

2) Dimension

- Size: L X W (35 x 21.1 mm),
- Height: 11.8mm (Sensor socket applied, standard product), 8mm (Sensor socket not applied, user request)
- 2mm instrument hall: 4ea

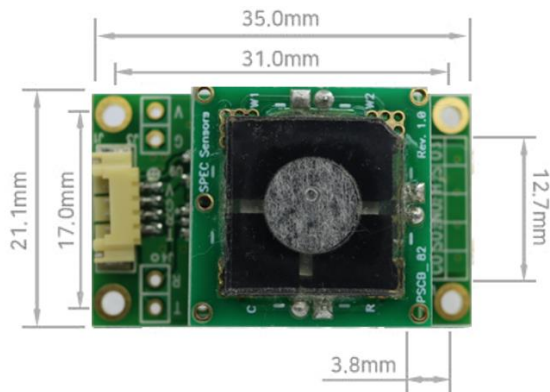

Size: L X W (35 x 21.1 mm)



Communication Protocol

1) Basic setting

- TTL level: DC 3.3 V or 5.0V
- Baud: 9600
- Data bits: 8
- Stop bits: 1
- Parity: None
- Flow Control: None

2) Communication command

Command	Function
\r, <CR>	Once Data output Output: SN [XXXXXXXXXXXX], PPB [0 : 999999], TEMP [-99 : 99], RH [0 : 99], ADC[ADCCount], TempDigital, RHDigital
C c r	CONTINUOUS data output It is initialized after restarting and the state level is not stored in the internal memory
Z	Zero user calibration Calibrate by recalculating the sensor value so that the sensor output is 0PPM
B	Barcode entry Enter the barcode information recorded on the sensor
S	Span user calibration Calibration by injecting calibration gas to recalculate the measurement sensitivity of the sensor (based on PPM)
E	Internal memory readout Check the setting information value stored inside the module
D r	LED ON/OFF Status information is not stored in the internal memory
r r	System reset

3) Communication command example

```
'\r'  
081821011255, 212, 23, 18, 2194921, 23490, 18665  
  
'C\r'  
'c\r'  
081821011255, 212, 23, 18, 2194921, 23490, 18665  
  
'S'  
Enter span gas value in PPM: xxx.xx\r(Enter span gas value in PPM: 4.50\r)  
Setting span...  
done  
  
'Z'  
Setting zero...  
done  
  
'B'  
Remove Sensor and Scan:  
Setting OC...done  
  
'e'  
Serial Number= 112020010530  
Barcode= 081821011255 110507 NO2 2108 -28.57  
ADC Zero= 2165186  
ADC_SpanCalValue= 1890818  
Temperature Zero(x1000)= 24366  
Humidity Zero(x1000)= 16797  
Temperature Span(x1000)= 24205  
Humidity Span(x1000)= 17139  
Calibration GAS(x100)(ppm)= 250  
Calibration InA(x100)= -2857  
Max Range(ppm)= 5  
NoneSensorADC Zero= 2165186  
Firmware Version= 2022-03-23B-04"  
  
'r\r'  
reset  
  
'D\r'  
LED OFF  
LED ON
```

Arduino connection method and example code

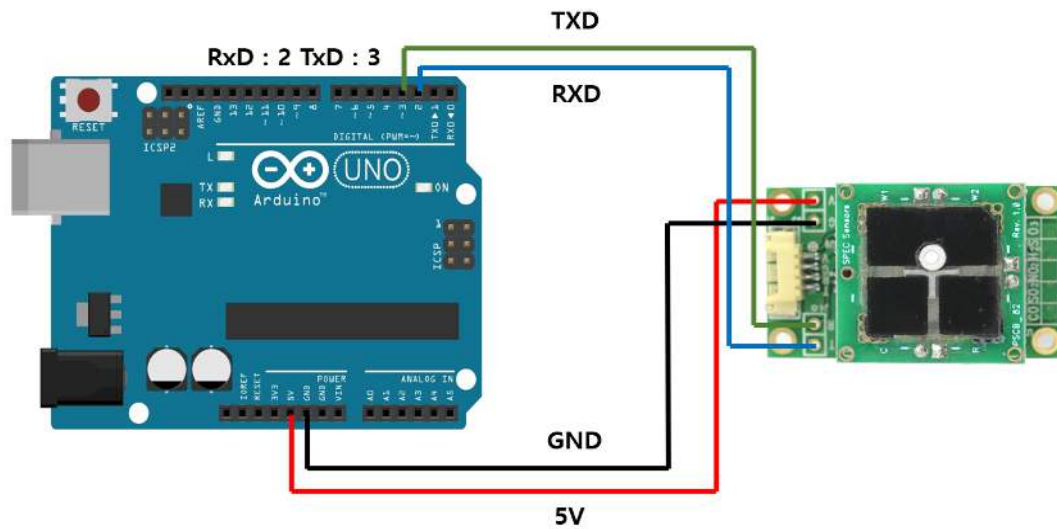

```
#define ContinueMode  disable
#define PollingMode  enable

#include<SoftwareSerial.h>
const int rxPin = 2;
const int txPin = 3;
SoftwareSerial Serial1(rxPin, txPin);

void setup()
{
  Serial.begin(9600);
  Serial1.begin(9600);
  delay(1000);

  #if ContinueMode
    Serial.println("Continuous Mode");
  #else if PollingMode
    Serial.println("Polling Mode");
  #endif

  Serial.println("Serial, Conc.(PPB), Temp.(C), Rh(%), Adc.(Counts), Temp.(Counts), Rh(%Counts)");
}
```



```
#if ContinueMode
  Serial1.write('c');
  Serial1.write('\r');
#endif
}

void loop()
{
  #if PollingMode
    Serial1.write('\r');
    delay(1000);
  #else
    delay(100);
  #endif
  while (Serial1.available()) // read from AGSM port, send to Serial port to interrupt continuous
output send 'c"/r' without line ending, may have to send more than once.
  {
    int inByte = Serial1.read();
    Serial.write(inByte);
  }
}
```

AGSM-SO₂-5 Long Term Graph

This is a graph accumulated for about two months to understand the trend of the AGSM-SO₂-5 Sensor.

* The sensor under test is placed in Allsensing Co., Ltd Lab.

Lab Average Temp, Humi: 28°C, 48%

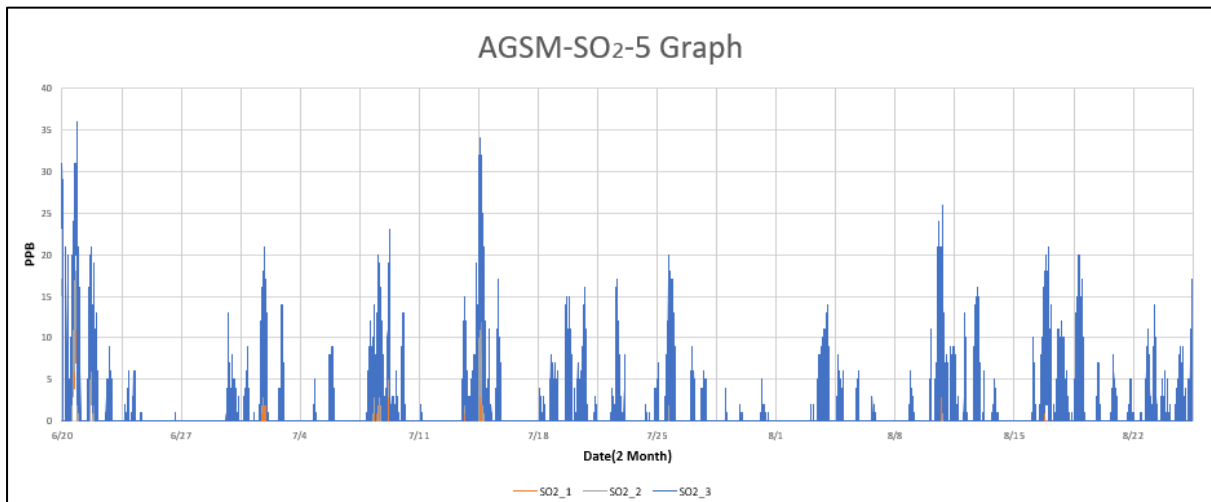

Precautions for use

- Please use it within the specified specifications and be careful with the connection.
 - Using in the vicinity of excessive chemicals may damage the sensor.
 - If left unattended at high humidity for a long time, there is a possibility of sensor malfunction.
 - Soldering with the sensor installed may damage the sensor.
 - If a certain amount of shock occurs, malfunction may occur for a short time.
- * Failure to follow these instructions may results in product damage.
- * For safety reasons, it is recommended to use it as an auxiliary device or a supplementary device.

Manufacturer / Contact (A/S)

- Homepage: <https://www.allsensing.com/>
- E-MAIL: support@allsensing.com

Docs revision history

Version	Changes Contents
V1.0	Drafting (2022.03.11)
V1.1	Fixing typos and add Arduino connection method and code (2022.04.28)
V1.2	Fixing typos and added AGSM-SO ₂ -5 Long Term graph (2022.09.29)