

# Horizontal Plug: 10-9159-100

## General Description



The 9159 series of Board-to-Board interconnect system allows two PCB's to be mated end-to-end creating strips of LED lighting. Designed specifically for the unique Solid State Lighting (SSL) market requiring coplanar (horizontal-to-horizontal) PCB mating with a 5 Amp current rating in the smallest package available. These single sided SMT connectors are perfect for both FR4 and metal boards where you need to butt the boards up together to minimize separation. Availability of both white and black insulation colors make them perfect for lighting as well as industrial applications. With sizes from 2p-6p, these high reliability connectors boast gold plated beryllium copper receptacle contacts for harsh environments.

### APPLICATIONS

- Coplanar PCB mating in SSL products
- LED linear lighting strips
- Application Notes: refer to 201-01-123
- Specification Notes: refer to 201-01-119

### FEATURES AND BENEFITS

- Single sided SMT: supports FR4 and metal PCB's
- 5 Amp current rating: exceeds general market needs
- 5.5mm mated width: minimizes PCB space to decrease LED pitch
- Gold plated BeCu spring contacts: reliability for harsh environments
- Optional retaining clip: provides positive connector mating during vibration
- Available in white: supports SSL market preferences

### ELECTRICAL

- Current Rating: 5 Amps / Contact
- Voltage Rating: 125 VAC (RMS) or DC equivalent

### ENVIRONMENTAL

- Operating Temperature: -40°C to +125°C
- Storage Temperature: -40°C to +70°C

### MECHANICAL

- Insulator Material: Nylon: UL94V-0
- Contact Material: BeCu / Phos Bronze
- Plating: Gold / Tin over Nickel
- Durability: 10 Cycles

### HOW TO ORDER

**10**

Plug

**9159**

Series

**00X**

Number of Ways

Code	No of Ways	Details
002	2	Page 3
003	3	Page 4
004	4	Page 5
005	5	Page 6
006	6	Page 7

Optional Retaining Clip  
Page 8

**1**

2 Part  
PCB Strip  
Connector

**01**

Connector  
Pitch  
01 = 3mm

**9**

Color/Approval

Code	Color	Approval
8	Black	UL Approved
9	White	UL Approved

**16**

Plating Option

Code	Contact	Bracket
16	Gold in Contact Area Tin on Solder Tail	Tin all over



Safety Standards: UL 1977-File #E90723

# Horizontal Plug: 10-9159-100

## 2 Position

### PLUG 2 WAY 2 PART PCB STRIP CONNECTOR

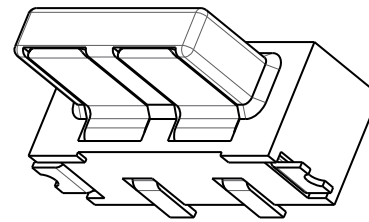
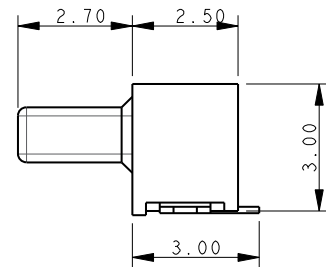
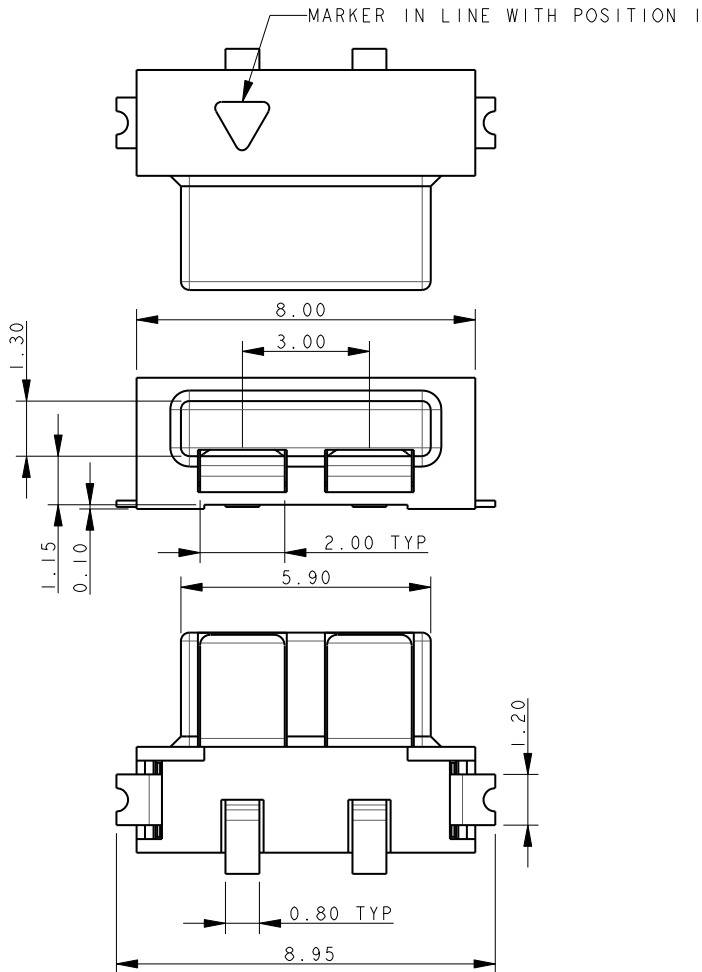

#### NOTES:

1. FOR MORE INFORMATION REFER TO PRODUCT SPEC 201-01-119
2. DIMENSIONS ARE REFERENCE DIMENSIONS UNLESS TOLERANCED.
3. INSULATOR MATERIAL: NYLON 46.
4. CONTACT MATERIAL: COPPER ALLOY, SELECTIVE GOLD OVER NICKEL TIN PLATED ON TAILS.
5. BRACKETS: COPPER ALLOY, TIN PLATED.
6. OUTLINE OF CONNECTOR.
7. PACKING TAPE AND REEL, QUANTITY 1400 PER REEL.
8. OPTIONAL RETAINING CLIP, SEE PAGE 8.

### 2 WAY PCB BOARD LAYOUT

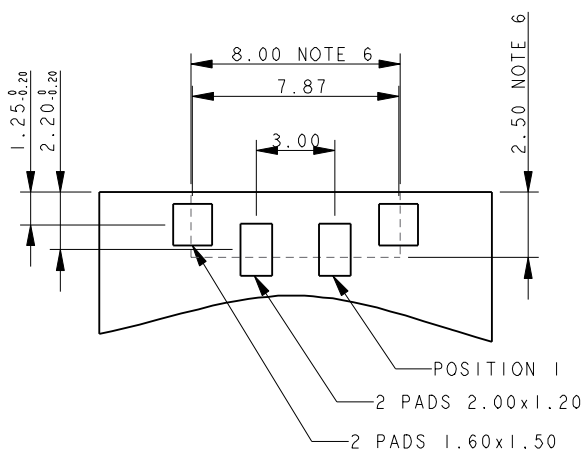

### PACKING DETAILS

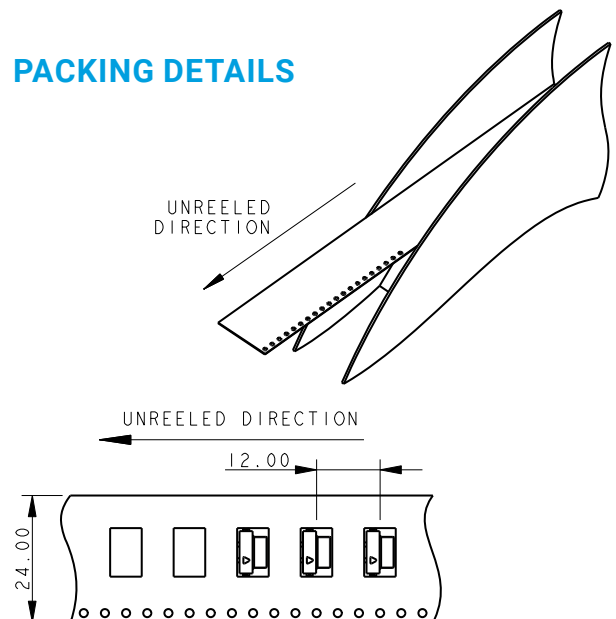

# Horizontal Plug: 10-9159-100

## 3 Position



### PLUG 3 WAY 2 PART PCB STRIP CONNECTOR

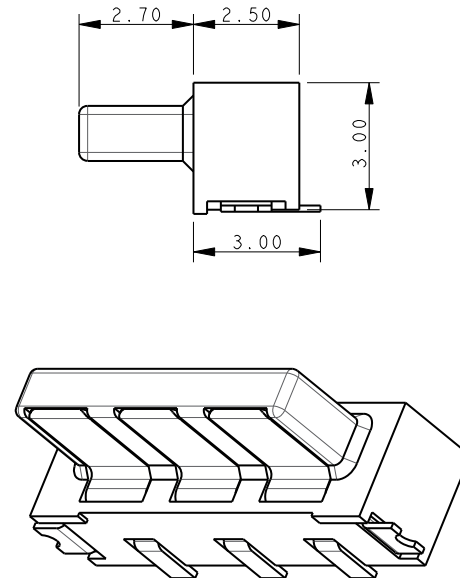
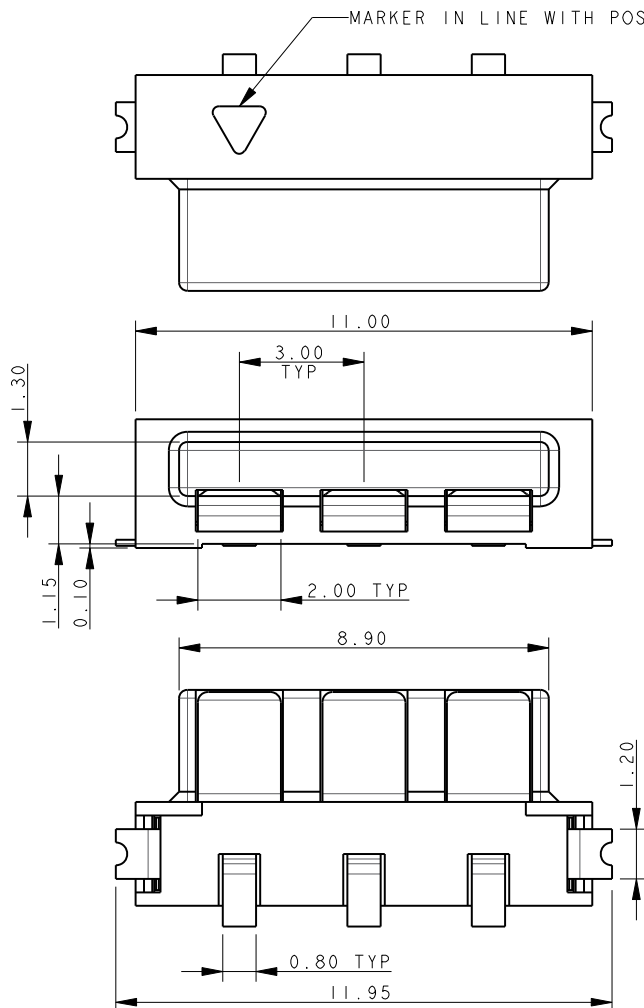

#### NOTES:

1. FOR MORE INFORMATION REFER TO PRODUCT SPEC 201-01-119.
2. DIMENSIONS ARE REFERENCE DIMENSIONS UNLESS TOLERANCED.
3. INSULATOR MATERIAL: NYLON 46.
4. CONTACT MATERIAL: COPPER ALLOY, SELECTIVE GOLD OVER NICKEL TIN PLATED ON TAILS.
5. BRACKETS: COPPER ALLOY, TIN PLATED.
6. OUTLINE OF CONNECTOR.
7. PACKING TAPE AND REEL, QUANTITY 1400 PER REEL.
8. OPTIONAL RETAINING CLIP, SEE PAGE 8.

### 3 WAY PCB BOARD LAYOUT

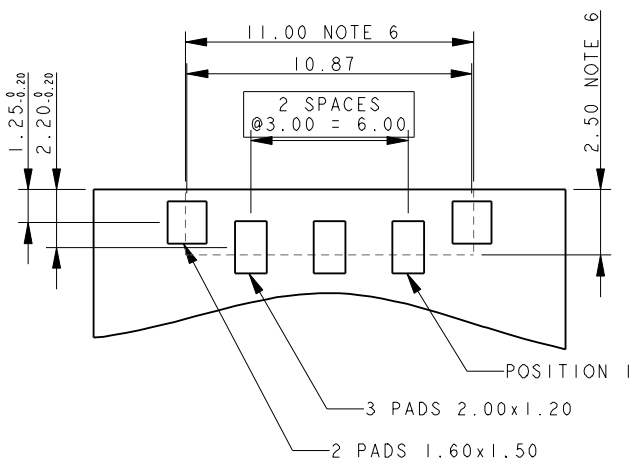

### PACKING DETAILS

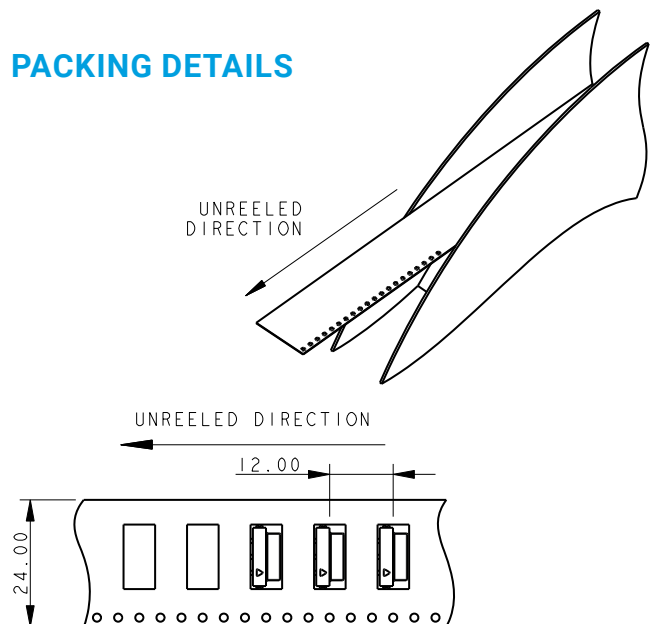

# Horizontal Plug: 10-9159-BTB

## 4 Position

### PLUG 4 WAY 2 PART PCB STRIP CONNECTOR

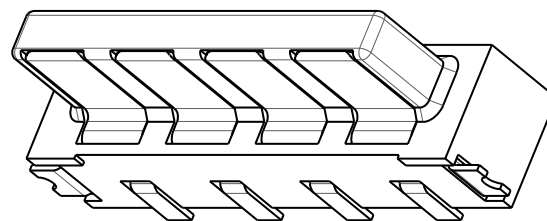
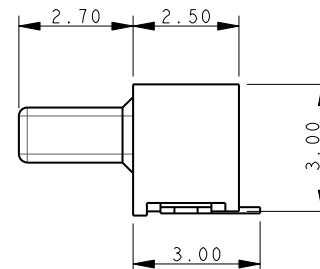
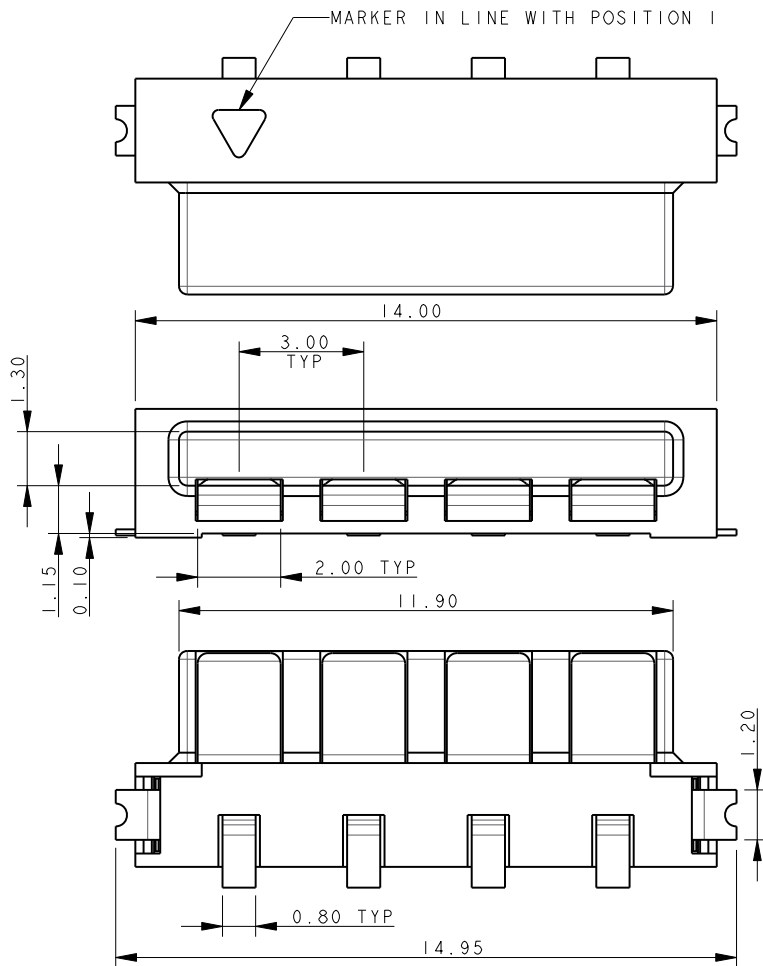

#### NOTES:

1. FOR MORE INFORMATION REFER TO PRODUCT SPEC 201-01-119.
2. DIMENSIONS ARE REFERENCE DIMENSIONS UNLESS TOLERANCED.
3. INSULATOR MATERIAL: NYLON 46.
4. CONTACT MATERIAL: COPPER ALLOY, SELECTIVE GOLD OVER NICKEL TIN PLATED ON TAILS.
5. BRACKETS: COPPER ALLOY, TIN PLATED.
6. OUTLINE OF CONNECTOR.
7. PACKING TAPE AND REEL, QUANTITY 1400 PER REEL.
8. OPTIONAL RETAINING CLIP, SEE PAGE 8.

### 4 WAY PCB BOARD LAYOUT

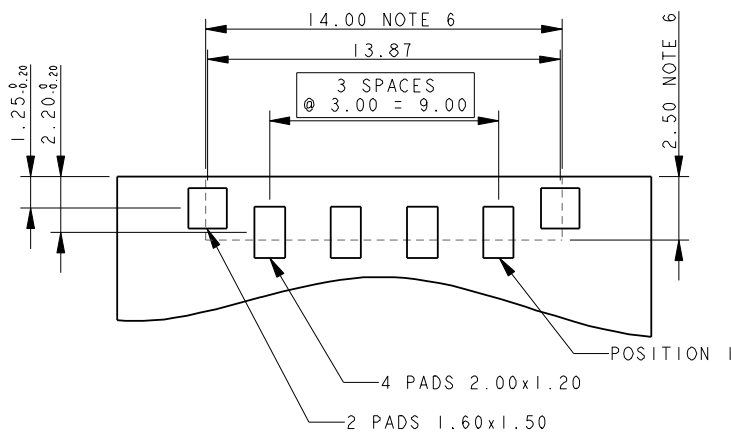

### PACKING DETAILS

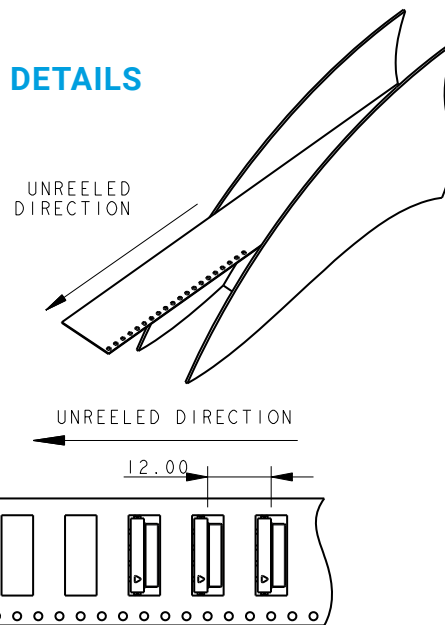

# Horizontal Plug: 10-9159-100

## 5 Position

### PLUG 5 WAY 2 PART PCB STRIP CONNECTOR

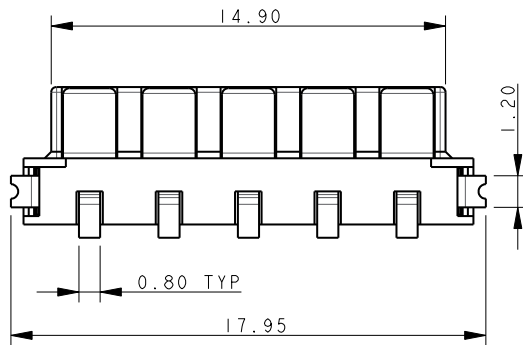
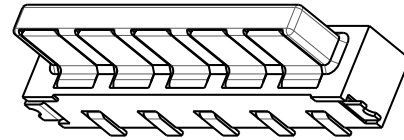
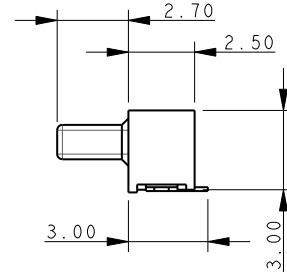
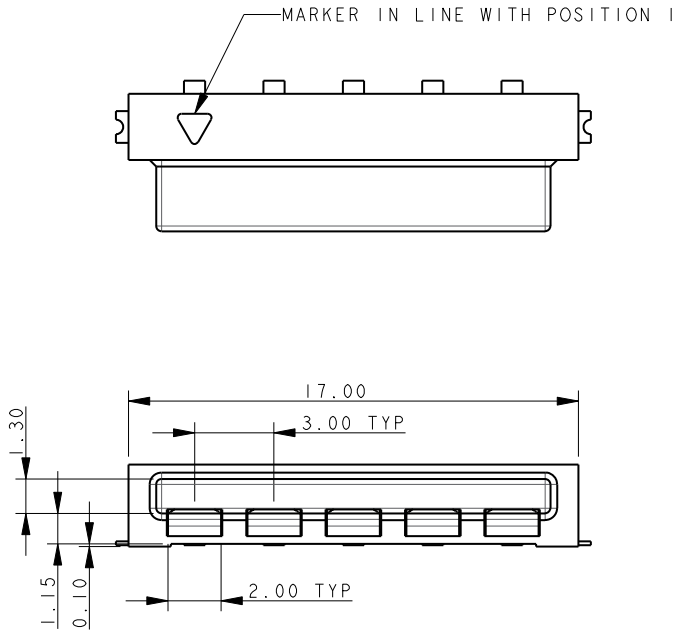

**NOTES:**

1. FOR MORE INFORMATION REFER TO PRODUCT SPEC 201-01-119.
2. DIMENSIONS ARE REFERENCE DIMENSIONS UNLESS TOLERANCED.
3. INSULATOR MATERIAL: NYLON 46.
4. CONTACT MATERIAL: COPPER ALLOY, SELECTIVE GOLD OVER NICKEL TIN PLATED ON TAILS.
5. BRACKETS: COPPER ALLOY, TIN PLATED.
6. OUTLINE OF CONNECTOR.
7. PACKING TAPE AND REEL, QUANTITY 1400 PER REEL.
8. OPTIONAL RETAINING CLIP, SEE PAGE 8.

### 5 WAY PCB BOARD LAYOUT

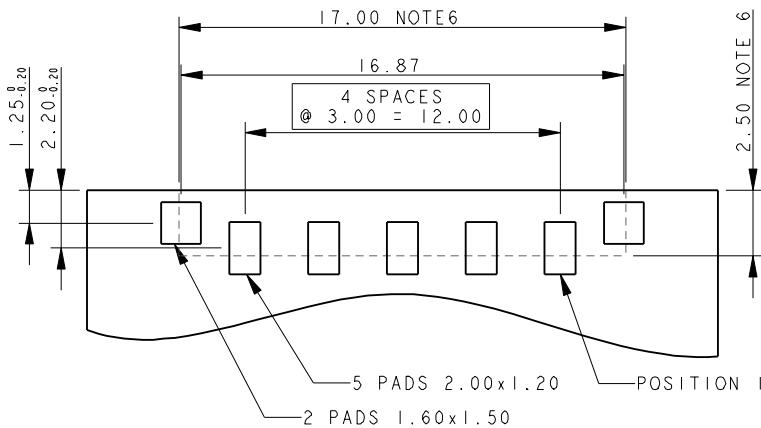

### PACKING DETAILS

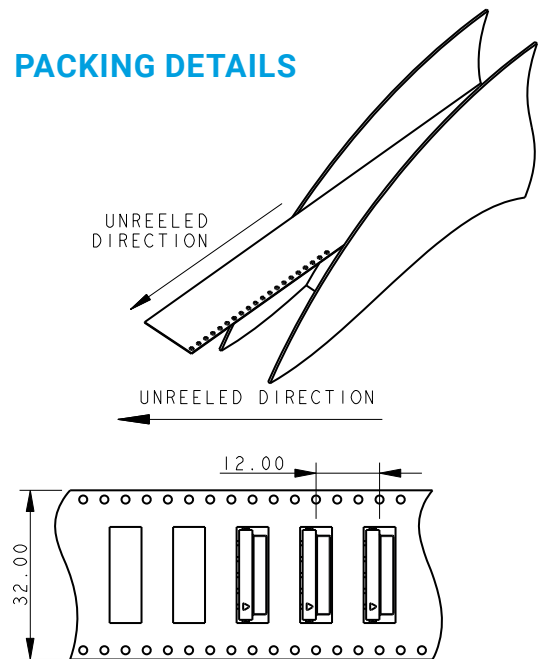

# Horizontal Plug: 10-9159-100

## 6 Position

### PLUG 6 WAY 2 PART PCB STRIP CONNECTOR

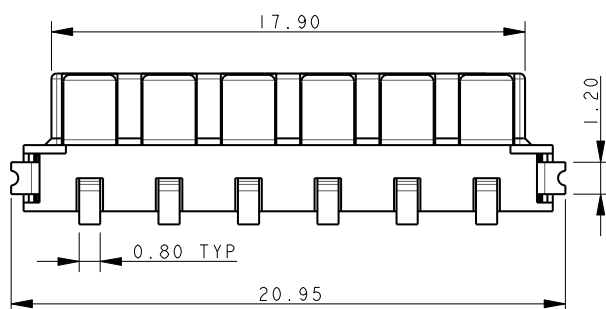
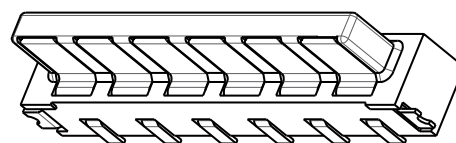
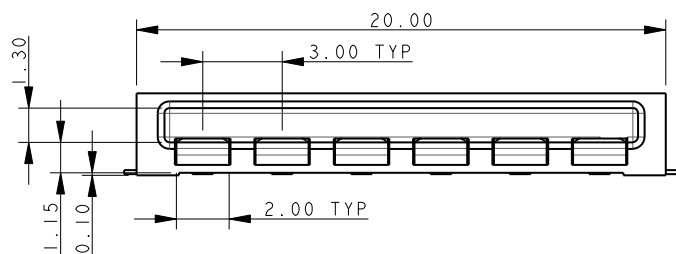
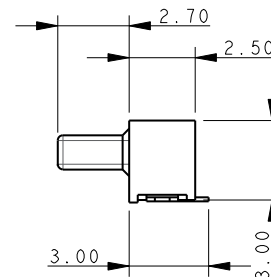
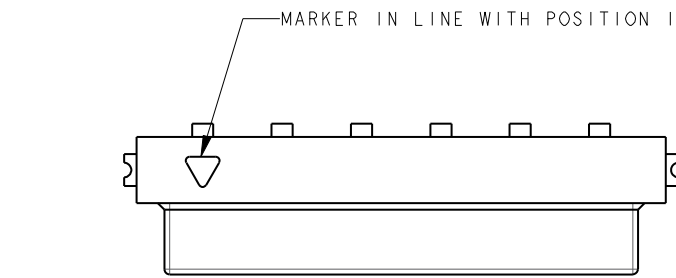

#### NOTES:

1. FOR MORE INFORMATION REFER TO PRODUCT SPEC 201-01-119.
2. DIMENSIONS ARE REFERENCE DIMENSIONS UNLESS TOLERANCED.
3. INSULATOR MATERIAL: NYLON 46.
4. CONTACT MATERIAL: COPPER ALLOY, SELECTIVE GOLD OVER NICKEL TIN PLATED ON TAILS.
5. BRACKETS: COPPER ALLOY, TIN PLATED.
6. OUTLINE OF CONNECTOR.
7. PACKING TAPE AND REEL, QUANTITY 1400 PER REEL.
8. OPTIONAL RETAINING CLIP, SEE PAGE 8.

### 6 WAY PCB BOARD LAYOUT

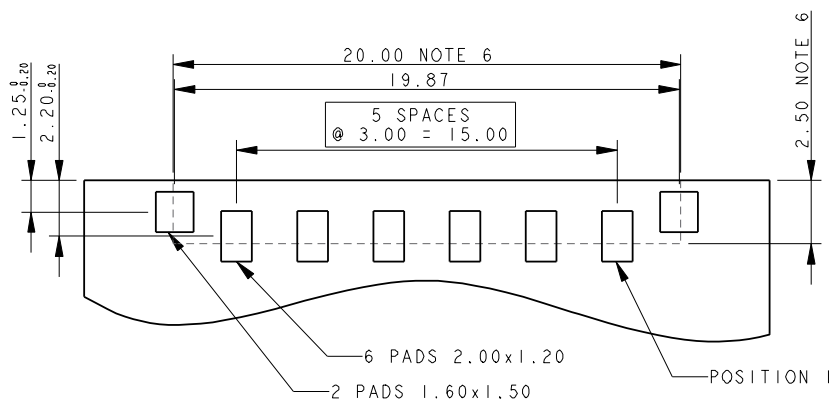

### PACKING DETAILS

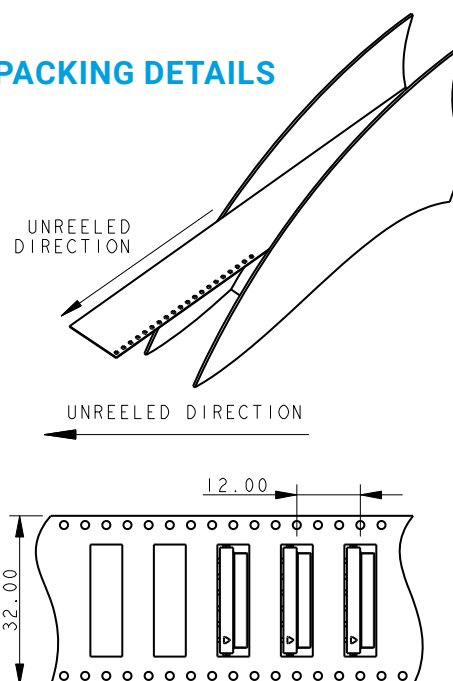

# Horizontal Plug: 10-9159-100

## Accessory Retaining Clip/Plug Assembly/Mated Assembly/Hand Insertion Tool



### 80-9159-4200-00-000 ACCESSORY RETAINING CLIP

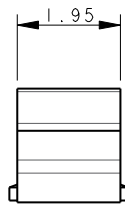
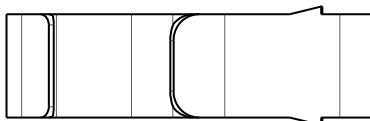
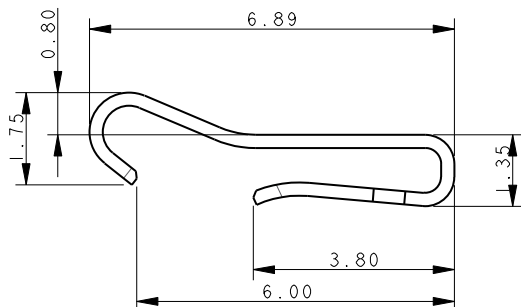

### HAND INSERTION TOOL 06-9159-7025-01-000

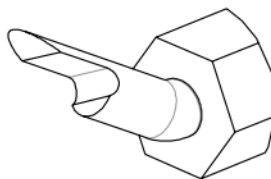

### PLUG ASSEMBLY FOR REFERENCE ONLY CLIP INSERTED INTO 10-9159-00X-101-X06

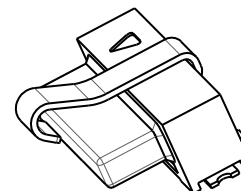
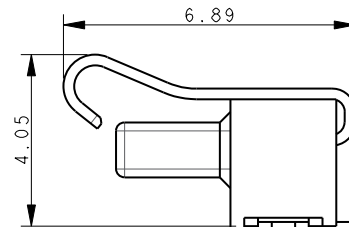

### MATED ASSEMBLY – FOR REFERENCE ONLY 10-9159-00X-101-X06 MATED WITH 20-9159-00X-X06

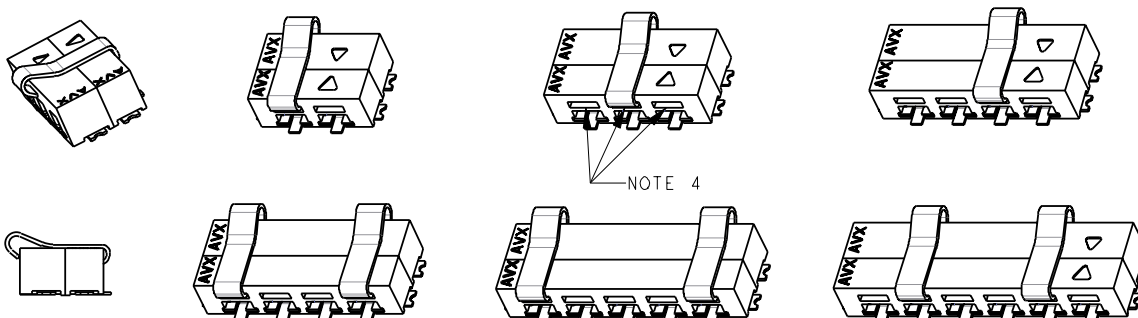

Description	# of Positions	Part Number	UL File #
Horizontal Plug w/pre-installed locking clip	2	58 9159 002 000 015	E90723
Horizontal Plug w/pre-installed locking clip	3	58 9159 003 000 015	E90723
Horizontal Plug w/pre-installed locking clip	4	58 9159 004 000 015	E90723
Horizontal Plug w/pre-installed locking clips	5	58 9159 005 000 015	E90723
Horizontal Plug w/pre-installed locking clips	6	58 9159 006 000 015	E90723

**NOTES:**

1. CLIP TO RETAIN MATED PAIR PLUG AND SOCKET.
2. MATERIAL: STAINLESS STEEL.
3. TAIL INSERTED INTO SLOT OF 9159 2 PART PLUG (10-9159-00X-101-006). LEADING EDGE CLIPS OVER SOCKET.
4. ALL DIMENSIONS SHOWN ARE REFERENCE DIMENSIONS.
5. RECOMMENDED 1 CLIP IN 2, 3 AND 4 WAY. 2 CLIPS IN 5 AND 6 WAY. POSITIONS AT CUSTOMER DISCRETION.

# Horizontal Plug: 10-9159-100

## PLUG MAXIMUM CONNECTOR MISALIGNMENT

### PLUG MAXIMUM CONNECTOR MISALIGNMENT

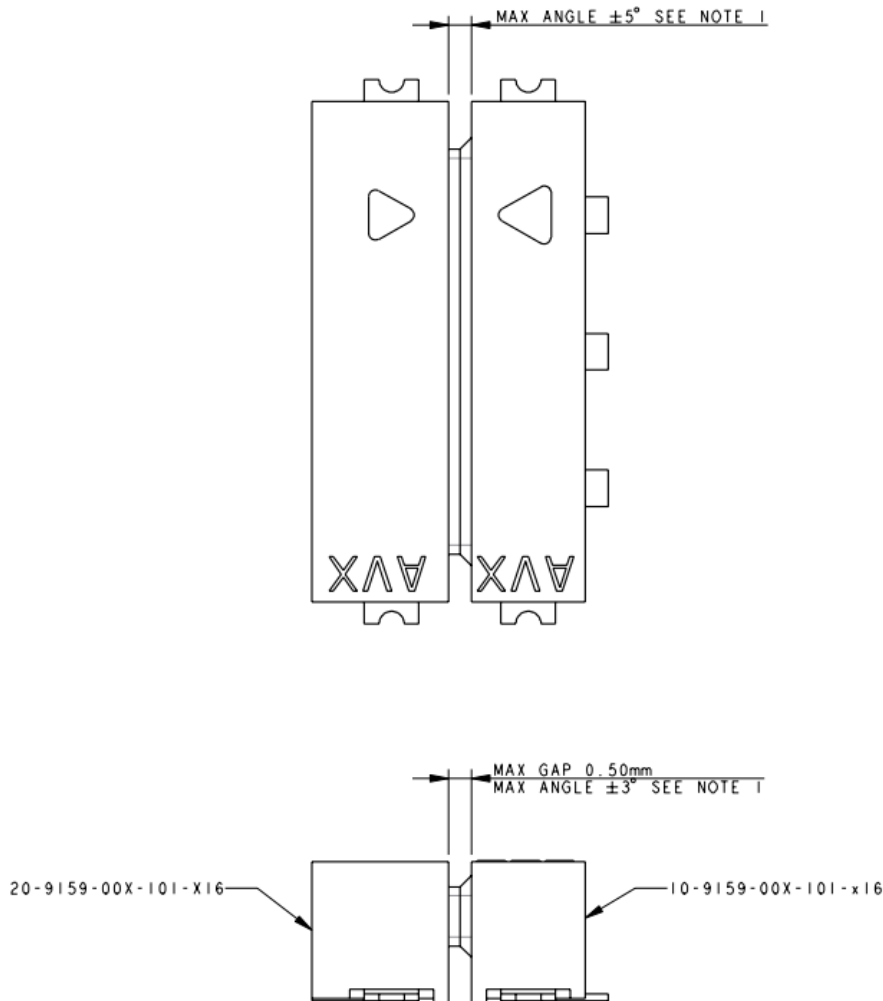

#### NOTES:

1. AT THE MAXIMUM ANGLE BETWEEN THE CONNECTORS THE GAP MUST NOT EXCEED 0.50mm.
2. THE FIGURES GIVEN ARE THE MAXIMUM PERMITTED MISALIGNMENT, FOR BEST RESULTS MISALIGNMENT SHOULD BE KEPT TO A MINIMUM.
3. 3 WAY CONNECTOR SHOWN, DIMENSIONS APPLY TO 2, 3, 4, 5, AND 6 WAY.