

VAL-MS 1500DC-PV/2+V-FM - Type 2 surge arrester



1033725

<https://www.phoenixcontact.com/us/products/1033725>

Please be informed that the data shown in this PDF document is generated from our online catalog. Please find the complete data in the user documentation. Our general terms of use for downloads are valid.



Surge protective device for 2-pos. isolated and grounded 1,500 V DC PV systems, for DIN rail mounting, 3-pos. base element with remote indication contact, three pluggable temperature-monitored protective elements, status message on each plug.

Your advantages

- Quality proven millions of times over in the widest range of applications
- Rapid installation with bridges, thanks to industry-standard overall width of 1 HP
- Easy testing and insulation measurement, thanks to pluggable protection modules
- Wide range of applications due to various nominal voltages
- High degree of modularity provides individual solutions for every application

Commercial data

Item number	1033725
Packing unit	1 pc
Minimum order quantity	1 pc
Sales key	CL01
Product key	CL1324
Catalog page	Page 73 (C-4-2019)
GTIN	4055626539942
Weight per piece (including packing)	362.6 g
Weight per piece (excluding packing)	337.76 g
Customs tariff number	85354000
Country of origin	DE

VAL-MS 1500DC-PV/2+V-FM - Type 2 surge arrester



1033725

<https://www.phoenixcontact.com/us/products/1033725>

Technical data

Notes

General

Note	The device is intended for touch proof installation in a housing. Ensure that there is a gap of at least 8 mm between the active and grounded parts in the connection area.
------	---

Product properties

IEC test classification	PV II PV T2
EN type	T2
IEC power supply system	DC
Type	DIN rail module, two-section, divisible
Distance between live and grounded parts	8 mm
Product type	PV arrester
Product family	VALVETRAB MS
Installation location	Interior
Installation location of the disconnect device	Internal
Accessibility	Accessible
Connection configuration	Y configuration
SPD failure behavior	OCFM (Open-Circuit Failure Mode)
Surge protection fault message	Optical, remote indicator contact

Insulation characteristics

Overvoltage category	III
Pollution degree	2

Electrical properties

Indicator/remote signaling

Connection name	Remote fault indicator contact
Switching function	Changeover contact
Operating voltage	30 V AC 30 V DC
Operating current	1 A AC 1 A DC

Connection data

Connection method	Screw connection
Screw thread	M5
Tightening torque	3 Nm (1.5 mm ² ... 16 mm ²) 4.5 Nm (25 mm ² ... 35 mm ²)
Stripping length	16 mm
Conductor cross section flexible	1.5 mm ² ... 25 mm ²

VAL-MS 1500DC-PV/2+V-FM - Type 2 surge arrester



1033725

<https://www.phoenixcontact.com/us/products/1033725>

Conductor cross section rigid	1.5 mm ² ... 35 mm ²
Conductor cross section AWG	15 ... 2
Connection method	Fork-type cable lug
Conductor cross section flexible	1.5 mm ² ... 16 mm ²

Remote fault indicator contact

Connection method	Plug-in/screw connection via COMBICON
Screw thread	M2
Tightening torque	0.25 Nm
Stripping length	7 mm
Conductor cross section flexible	0.14 mm ² ... 1.5 mm ²
Conductor cross section rigid	0.14 mm ² ... 1.5 mm ²
Conductor cross section AWG	28 ... 16

Dimensions

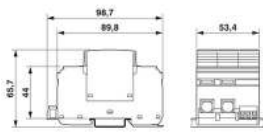
Dimensional drawing	
Width	53.4 mm
Height	98.7 mm
Depth	65.7 mm
Horizontal pitch	3 Div.

Material specifications

Flammability rating according to UL 94	V-0
CTI value of material	600
Insulating material	PA 6.6-FR PBT-FR
Material group	I
Housing material	PA 6.6-FR PBT-FR

Mechanical properties

Mechanical data

Open side panel	No
-----------------	----

Protective circuit

Mode of protection	(L+) - (L-) (L+) - PE (L-) - PE
Direction of action	(L+)-PE & (L-)-PE & (L+)-(L-)
Rated load current I _L	80 A

VAL-MS 1500DC-PV/2+V-FM - Type 2 surge arrester



1033725

<https://www.phoenixcontact.com/us/products/1033725>

Residual current I_{PE}	$\leq 350 \mu\text{A DC}$
	$\leq 600 \mu\text{A AC}$
Standby power consumption P_C	$\leq 250 \text{ mVA}$
Nominal discharge current $I_n (8/20) \mu\text{s}$	15 kA
Maximum discharge current $I_{max} (8/20) \mu\text{s}$	30 kA
Total discharge current $I_{total} (8/20) \mu\text{s}$	30 kA
Voltage protection level U_p	$\leq 5 \text{ kV}$
Residual voltage U_{res}	$\leq 3.8 \text{ kV (at 3 kA)}$
	$\leq 4.1 \text{ kV (at 5 kA)}$
	$\leq 4.4 \text{ kV (at 10 kA)}$
	$\leq 5 \text{ kV (at 15 kA)}$
	$\leq 5.3 \text{ kV (at 20 kA)}$
	$\leq 5.7 \text{ kV (at 30 kA)}$
	$\leq 6 \text{ kV (at 40 kA)}$
Response time t_A	$\leq 25 \text{ ns}$

PV protective circuit

Connection configuration	Y configuration
SPD failure behavior	OCFM (Open-Circuit Failure Mode)

Protective circuit DC voltage side (DC)

Open circuit voltage U_{OCSTC}	$\leq 1250 \text{ V DC}$
Maximum discharge current $I_{max} (8/20) \mu\text{s}$	30 kA
Response time t_A	$\leq 25 \text{ ns}$
Total discharge current $I_{total} (8/20) \mu\text{s}$	30 kA
Nominal discharge current $I_n (8/20) \mu\text{s}$	15 kA
Rated load current I_L	80 A
Continuous operating current I_{CPV}	$< 350 \mu\text{A}$
Maximum continuous operating voltage U_{CPV}	1500 V DC
Short-circuit current rating I_{SCPV}	2000 A
Residual voltage U_{res}	$\leq 3.8 \text{ kV (at 3 kA)}$
	$\leq 4.1 \text{ kV (at 5 kA)}$
	$\leq 4.4 \text{ kV (at 10 kA)}$
	$\leq 5 \text{ kV (at 15 kA)}$
	$\leq 5.3 \text{ kV (at 20 kA)}$
	$\leq 5.7 \text{ kV (at 30 kA)}$
	$\leq 6 \text{ kV (at 40 kA)}$
Residual current I_{PE}	$\leq 350 \mu\text{A DC}$
	$\leq 600 \mu\text{A AC}$
Voltage protection level U_p	$\leq 5 \text{ kV}$
Standby power consumption P_C	$\leq 250 \text{ mVA}$

Additional technical data

Maximum discharge current $I_{max} (8/20) \mu\text{s}$	40 kA
Nominal discharge current $I_n (8/20) \mu\text{s}$	20 kA (4x (5x I_n 120 s) 30 min))

VAL-MS 1500DC-PV/2+V-FM - Type 2 surge arrester



1033725

<https://www.phoenixcontact.com/us/products/1033725>

Environmental and real-life conditions

Ambient conditions

Degree of protection	IP20 (only when all terminal points are used)
Ambient temperature (operation)	-40 °C ... 85 °C
Ambient temperature (storage/transport)	-40 °C ... 85 °C
Altitude	≤ 3000 m (amsl)
Permissible humidity (operation)	5 % ... 95 %
Shock (operation)	30g (Half-sine / 11 ms / 3x ±X, ±Y, ±Z)
Vibration (operation)	5g (5-500 Hz/2.5 h/XYZ)

Approvals

UL specifications

Maximum continuous operating voltage MCOV	1500 V DC
Short-circuit current rating (SCCR)	50 kA
Voltage protection rating VPR	4 kV
Nominal discharge current I_n	10 kA
Mode of protection	(DC+) - (DC-) (DC+) - G (DC-) - G
Nominal voltage	1500 V DC
Power distribution system	DC PV
SPD Type	1CA

UL indicator/remote signaling

Operating voltage	30 V AC
DC operating voltage	30 V DC
AC operating current	1 A AC
DC operating current	1 A DC

UL connection data

Tightening torque	30 lb _F -in.
Conductor cross section AWG	14 ... 2

Standards and regulations

Standards/specifications	EN 61643-31
Note	2019
Standards/specifications	IEC 61643-31
Note	2018

Mounting

Mounting type	DIN rail: 35 mm
---------------	-----------------

VAL-MS 1500DC-PV/2+V-FM - Type 2 surge arrester



1033725

<https://www.phoenixcontact.com/us/products/1033725>

Drawings

Circuit diagram

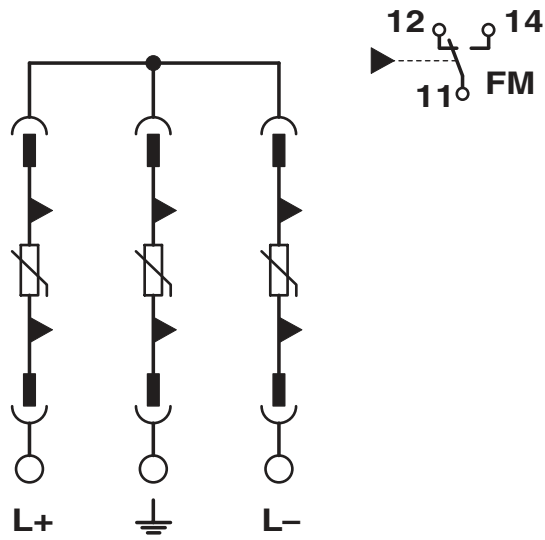

Dimensional drawing

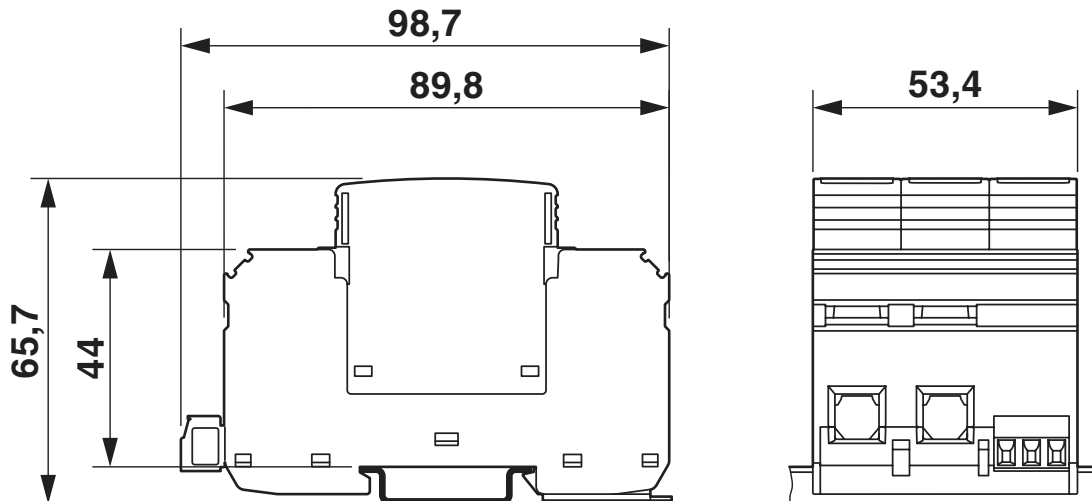

VAL-MS 1500DC-PV/2+V-FM - Type 2 surge arrester



1033725

<https://www.phoenixcontact.com/us/products/1033725>

Approvals

To download certificates, visit the product detail page: <https://www.phoenixcontact.com/us/products/1033725>



cUL Recognized
Approval ID: FILE E 330181



UL Recognized
Approval ID: FILE E 330181

CCA
Approval ID: NTR-NL 7937



KEMA-KEUR
Approval ID: 71-123544 REV.2



IECEE CB Scheme
Approval ID: NL-81006/A1

UAE-RoHS
Approval ID: 22-09-51250

cULus Recognized

VAL-MS 1500DC-PV/2+V-FM - Type 2 surge arrester



1033725

<https://www.phoenixcontact.com/us/products/1033725>

Classifications

ECLASS

ECLASS-11.0	27130805
ECLASS-13.0	27171402

ETIM

ETIM 8.0	EC000941
----------	----------

UNSPSC

UNSPSC 21.0	39121620
-------------	----------

VAL-MS 1500DC-PV/2+V-FM - Type 2 surge arrester



1033725

<https://www.phoenixcontact.com/us/products/1033725>

Environmental product compliance

China RoHS	Environmentally friendly use period: unlimited = EFUP-e
	No hazardous substances above threshold values

VAL-MS 1500DC-PV/2+V-FM - Type 2 surge arrester



1033725

<https://www.phoenixcontact.com/us/products/1033725>

Accessories

ZBN 18,LGS:ERDE - Marker for terminal blocks

2749589

<https://www.phoenixcontact.com/us/products/2749589>



Marker for terminal blocks, Strip, white, labeled, horizontal: Grounding symbol, mounting type: snapped, for terminal block width: 18 mm, lettering field size: 18 x 5 mm, Number of individual labels: 5

ZBN 18,LGS:L1-N,ERDE - Marker for terminal blocks

2749576

<https://www.phoenixcontact.com/us/products/2749576>



Marker for terminal blocks, Strip, white, labeled, horizontal: L1, L2, L3, N, GND, mounting type: snapped, for terminal block width: 18 mm, lettering field size: 18 x 5 mm, Number of individual labels: 5

VAL-MS 1500DC-PV/2+V-FM - Type 2 surge arrester



1033725

<https://www.phoenixcontact.com/us/products/1033725>

ZBN 18:UNBEDRUCKT - Zack marker strip

2809128

<https://www.phoenixcontact.com/us/products/2809128>



Zack marker strip, Strip, white, unlabeled, can be labeled with: CMS-P1-PLOTTER, PLOTMARK, mounting type: snapped, for terminal block width: 18 mm, lettering field size: 18 x 5 mm, Number of individual labels: 5

B-STIFT - Marker pen

1051993

<https://www.phoenixcontact.com/us/products/1051993>



Marker pen, for manual labeling of unprinted Zack strips, smear-proof and waterproof, line thickness 0.5 mm

VAL-MS 1500DC-PV/2+V-FM - Type 2 surge arrester



1033725

<https://www.phoenixcontact.com/us/products/1033725>

ATP-QTTCB - Partition plate

3206238

<https://www.phoenixcontact.com/us/products/3206238>

Partition plate, length: 102 mm, width: 2 mm, height: 102 mm, color: gray



VAL-MS 1500DC-PV-ST - Type 2 surge protection plug

1033727

<https://www.phoenixcontact.com/us/products/1033727>



Pack of three replacement plugs for PV arrester combinations from the VAL-MS 1500DC-PV-... product range

Phoenix Contact 2023 © - all rights reserved
<https://www.phoenixcontact.com>

Phoenix Contact USA
586 Fulling Mill Road
Middletown, PA 17057, United States
(+717) 944-1300
info@phoenixcon.com