

Application note : Ultra small, Low NF, Single Band LNA-IC for 600 MHz Band Applications

EVALUATION BOARD REFERENCE

Application Circuit for DTV (UHF)

Test Board (PCB) Diagram for Application Circuit

External Components

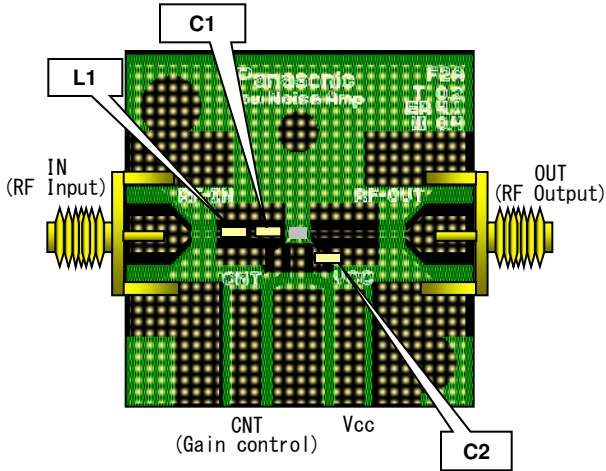

Components	Size	Value	Part Number	Vendor
L1	0603	8.2 nH	LQP03TN8N2H04	Murata
C1	0603	1 000 pF	GRM033B11C102KD01	Murata
C2	0603	100 000 pF	GRM33B30J104KE18	Murata

Notes) This application circuit is an example. The operation of mass production set is not guaranteed. You should perform enough evaluation and verification on the design of mass production set. You are fully responsible for the incorporation of the above application circuit and information in the design of your equipment.

Test Circuit Diagram

Electrical characteristics Reference Value

Note)  $V_{CC} = 2.85\text{ V}$ ,  $T_a = 25^\circ\text{C} \pm 2^\circ\text{C}$ , unless otherwise specified.

Parameter	Symbol	Condition	Typ	Unit
<b>DC electrical characteristics</b>				
Supply current HG	$I_{CCH}$	$V_{CC}$ current at High-Gain mode, No input signal	3.0	mA
Supply current LG	$I_{CCL}$	$V_{CC}$ current at Low-Gain mode, No input signal	1.0	$\mu\text{A}$

Note)  $V_{CC} = 2.85\text{ V}$ ,  $T_a = 25^\circ\text{C} \pm 2^\circ\text{C}$ ,  $f_{RX} = 2422\text{ MHz}$ ,  $PRX = -30\text{ dBm}$ , CW unless otherwise specified.

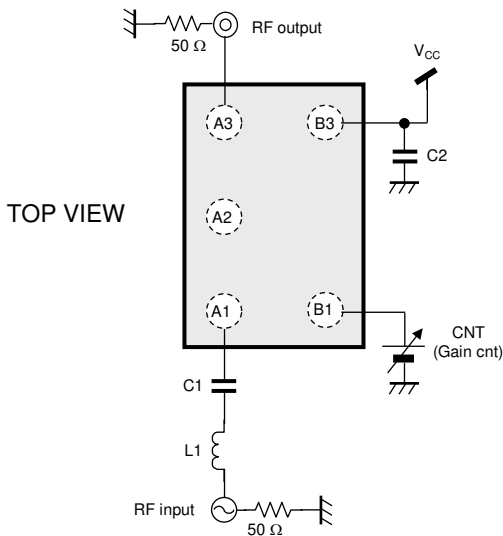

Parameter	Symbol	Conditions	Typ	Unit
<b>LNA AC electrical characteristics ( High Gain Mode )</b>				
Power Gain HG	GHS	High-Gain mode	15.0	dB
Noise Figure HG	NFH	High-Gain mode	1.3	dB
IIP3 +10 MHz offset HG	IIP3H1	$f_1 = f_{RX} + 10\text{MHz}$ $f_2 = f_{RX} + 20\text{MHz}$ Input 2 signals ( $f_1, f_2$ )	-4.0	dBm
Input P1dB	IP1dBH	High-Gain mode	-6.0	dBm
<b>LNA AC electrical characteristics ( Low Gain Mode )</b>				
Power Gain LG	GLS	$PRX = -20\text{ dBm}$	-4.0	dB
Noise Figure LG	NFL	Low-Gain mode	6.5	dB

**ABSOLUTE MAXIMUM RATINGS**

Parameter	Symbol	Rating	Unit	Note
Supply voltage	$V_{CC}$	3.6	V	*1
Supply current	$I_{CC}$	18	mA	—
Operating ambient temperature	$T_{opr}$	-25 to 75	°C	*2
Operating junction temperature	$T_j$	-40 to +125	°C	*2
Storage temperature	$T_{stg}$	-40 to +125	°C	*2
Input Voltage Range	IN (Pin No.A1)	—	V	*3
	CNT (Pin No.B1)	-0.3 to $V_{CC}$	V	—
	OUT (Pin No.A3)	—	V	*4
ESD	HBM (Human Body Model)	1	kV	—
	MM (Machine Model)	100	V	—

Notes). This product may sustain permanent damage if subjected to conditions higher than the above stated absolute maximum rating. This rating is the maximum rating and device operating at this range is not guaranteeable as it is higher than our stated recommended operating range.

When subjected under the absolute maximum rating for a long time, the reliability of the product may be affected.

\*1:The values under the condition not exceeding the above absolute maximum ratings and the power dissipation.

\*2:Except for the operating ambient temperature, operating junction temperature, and storage temperature, all ratings are for  $T_a = 25^\circ\text{C}$ .

\*3:RF signal input pin. Do not apply DC.

\*4:RF signal output pin. Do not apply DC.

**POWER DISSIPATION RATING**

PACKAGE	$\theta_{JA}$	PD ( $T_a=25^\circ\text{C}$ )	PD ( $T_a=75^\circ\text{C}$ )
WLCSP	1391.0°C/W	0.072W	0.036W

Note). For the actual usage, please refer to the PD- $T_a$  characteristics diagram in the package specification, supply voltage, load and ambient temperature conditions to ensure that there is enough margin follow the power and the thermal design does not exceed the allowable value.



**CAUTION**

Although this has limited built-in ESD protection circuit, but permanent damage may occur on it. Therefore, proper ESD precautions are recommended to avoid electrostatic damage to the MOS gates

**RECOMMENDED OPERATING CONDITIONS**

Parameter	Symbol	Min.	Typ.	Max.	Unit	Note
Supply voltage range	$V_{CC}$	2.5	2.85	3.0	V	*1

Note) \*1 : The values under the condition not exceeding the above absolute maximum ratings and the power dissipation.

## ELECTRICAL CHARACTERISTICS

Note)  $V_{cc} = 2.85\text{ V}$ ,  $T_a = 25^\circ\text{C} \pm 2^\circ\text{C}$ , unless otherwise specified.

Parameter	Symbol	Condition	Limits			Unit	Note
			Min	Typ	Max		
<b>DC electrical characteristics</b>							
Supply current HG	I <sub>ccH</sub>	V <sub>cc</sub> current at High-Gain mode No input signal	—	3.0	4.4	mA	—
Supply current LG	I <sub>ccL</sub>	V <sub>cc</sub> current at Low-Gain mode No input signal	—	1.0	10	μA	—
Switching voltage (High Gain Mode)	V <sub>IH</sub>	$V_{IH} = V_{cc} \times 0.90$	2.57	2.85	—	V	—
Switching voltage (Low Gain Mode)	V <sub>IL</sub>	$V_{IL} = V_{cc} \times 0.14$	—	0.0	0.4	V	—
Switching current(High)	I <sub>IH</sub>	Current at CNT pin $V_{IH} = V_{cc}$	—	4.6	20	μA	—

**ELECTRICAL CHARACTERISTICS (continued)**

Note)  $V_{cc} = 2.85\text{ V}$ ,  $T_a = 25^{\circ}\text{C} \pm 2^{\circ}\text{C}$ ,  $f_{RXa} = 620\text{ MHz}$ ,  $PRX = -30\text{ dBm}$ , CW unless otherwise specified.

Parameter	Symbol	Condition	Limits			Unit	Note
			Min	Typ	Max		
<b>LNA AC electrical characteristics</b>							
Power Gain HG	GHS	High-Gain mode	13.0	15.0	17.0	dB	—
Power Gain LG	GLS	Low-Gain mode PRX = -20 dBm	-7.5	-4.0	-1.0	dB	—
IIP3 +10 MHz offset HG	IIP3H1	High-Gain mode f1 = fRXa + 10 MHz f2 = fRXa + 20 MHz Input 2 signals (f1, f2)	-12	-4.0	—	dBm	—

**APPLICATION INFORMATION**  
**REFERENCE VALUES FOR DESIGN**

Notes)  $V_{cc} = 2.85\text{ V}$

$T_a = 25^{\circ}\text{C} \pm 2^{\circ}\text{C}$ ,  $f_{RXb} = 470\text{ MHz}, 620\text{ MHz}, 770\text{ MHz}$ ,  $PRX = -30\text{ dBm}$ , CW unless otherwise specified.

Parameter	Symbol	Conditions	Reference values			Unit	Note
			Min	Typ	Max		
<b>LNA AC electrical characteristics</b>							
Power Gain HG	GH	High-Gain mode	11.5	15.0	17.5	dB	*1
Power Gain LG	GL	Low-Gain mode PRX = -20 dBm	-8.0	-4.0	-1.0	dB	*1
Noise Figure HG	NFH	High-Gain mode	—	1.3	2.3	dB	*1,*3
Noise Figure LG	NFL	Low-Gain mode	—	6.5	8.5	dB	*1
IIP3 +10 MHz offset HG	IIP3H1	High-Gain mode f1 = fRXb + 10 MHz f2 = fRXb + 20 MHz Input 2 signals (f1, f2)	-13	-4.0	—	dBm	*1
IIP3 +10 MHz offset HG	IIP3H2	High-Gain mode f1 = fRXb - 10 MHz f2 = fRXb - 20 MHz Input 2 signals (f1, f2)	-13	-4.0	—	dBm	*1
Input P1dB HG	IP1dBH	High-Gain mode	-10	-6	—	dBm	*1
Reverse Isolation HG	ISOH	High-Gain mode	—	-24	—	dB	*2
Reverse Isolation LG	ISOL	High-Gain mode	—	-3.5	—	dB	*2

Note) \*1 : Checked by design, not production tested.  
 \*2 : Typical Value checked by design.  
 \*3 : Connector & substrate loss (0.10 dB) included.

**APPLICATION INFORMATION (continued)**  
**REFERENCE VALUES FOR DESIGN (continued)**

Notes)  $V_{CC} = 2.5\text{ V to }3.0\text{ V}$

$T_a = -25^\circ\text{C to }75^\circ\text{C}$  unless otherwise specified.

Parameter	Symbol	Conditions	Reference values			Unit	Note
			Min	Typ	Max		
<b>DC electrical characteristics</b>							
Supply current HG	I <sub>ccHT</sub>	V <sub>CC</sub> current at High-Gain mode No input signal	—	3.0	4.5	mA	*1
Supply current LG	I <sub>ccLT</sub>	V <sub>CC</sub> current at Low-Gain mode No input signal	—	1.0	10.0	μA	*1
Switching current (High)	I <sub>IHT</sub>	Current at CNT pin $V_{IH} = V_{CC}$	—	4.6	20	μA	*1

Note) \*1 : Checked by design, not production tested.

**APPLICATION INFORMATION (continued)**

**REFERENCE VALUES FOR DESIGN (continued)**

Notes)  $V_{cc} = 2.5\text{ V to }3.0\text{ V}$

$T_a = -25^\circ\text{C to }75^\circ\text{C}$ ,  $f_{RXb} = 470\text{ MHz, }620\text{ MHz, }770\text{ MHz}$ ,  $PRX = -30\text{ dBm}$ , CW unless otherwise specified

Parameter	Symbol	Conditions	Reference values			Unit	Note
			Min	Typ	Max		
<b>LNA AC electrical characteristics</b>							
Power Gain HG	GHT	High-Gain mode	11.0	15.0	18.0	dB	*1
Power Gain LG	GLT	Low-Gain mode PRX = -20 dBm	-8.5	-4.0	-1.0	dB	*1
Noise Figure HG	NFHT	High-Gain mode	—	1.3	3.0	dB	*1,*3
Noise Figure LG	NFLT	Low-Gain mode	—	6.5	9.0	dB	*1
IIP3 +10 MHz offset HG	IIP3H1Ta	High-Gain mode f1 = fRXb + 10 MHz f2 = fRXb + 20 MHz Input 2 signals (f1, f2)	-14.0	-4.0	—	dBm	*1
IIP3 +10 MHz offset HG	IIP3H2Ta	High-Gain mode f1 = fRXb - 10 MHz f2 = fRXb - 20 MHz Input 2 signals (f1, f2)	-14.0	-4.0	—	dBm	*1
Input P1dB HG	P1dBHT	High-Gain mode f1 = fRXb - 190 MHz PRX1 = -27 dBm f2 = fRXb - 95 MHz PRX2 = -33 dBm Input 2 signals (f1, f2)	-12.0	-6.0	—	dBm	*1

Note) \*1 : Checked by design, not production tested.

\*3 : Connector & substrate loss (0.10 dB) included.

PIN CONFIGURATION

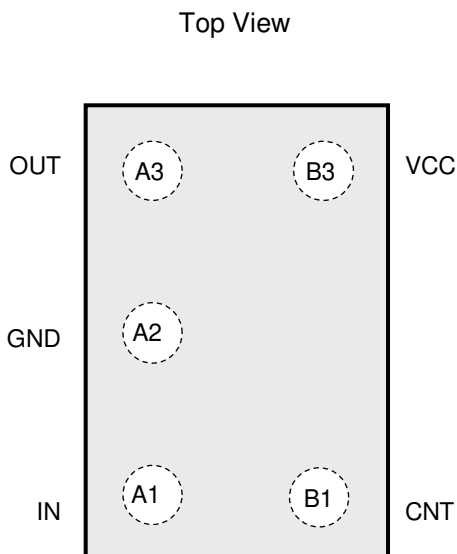

PIN FUNCTIONS

Pin No.	Pin name	Type	Description
A1	IN	Input	RF Input
A2	GND	Ground	GND
A3	OUT	Output	RF Output
B1	CNT	Input	High-Gain / Low-Gain switch L: Low-Gain Mode H: High-Gain Mode
B3	VCC	Power Supply	V <sub>CC</sub>

FUNCTIONAL BLOCK DIAGRAM

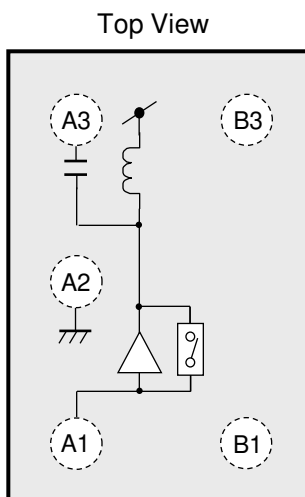

Notes) This circuit and these circuit constants show an example and do not guarantee the design as a mass-production set. This block diagram is for explaining functions. The part of the block diagram may be omitted, or it may be simplified.



PACKAGE INFORMATION ( Reference Data )

Package Code:ALGA005-W-0609ANA

Unit:mm

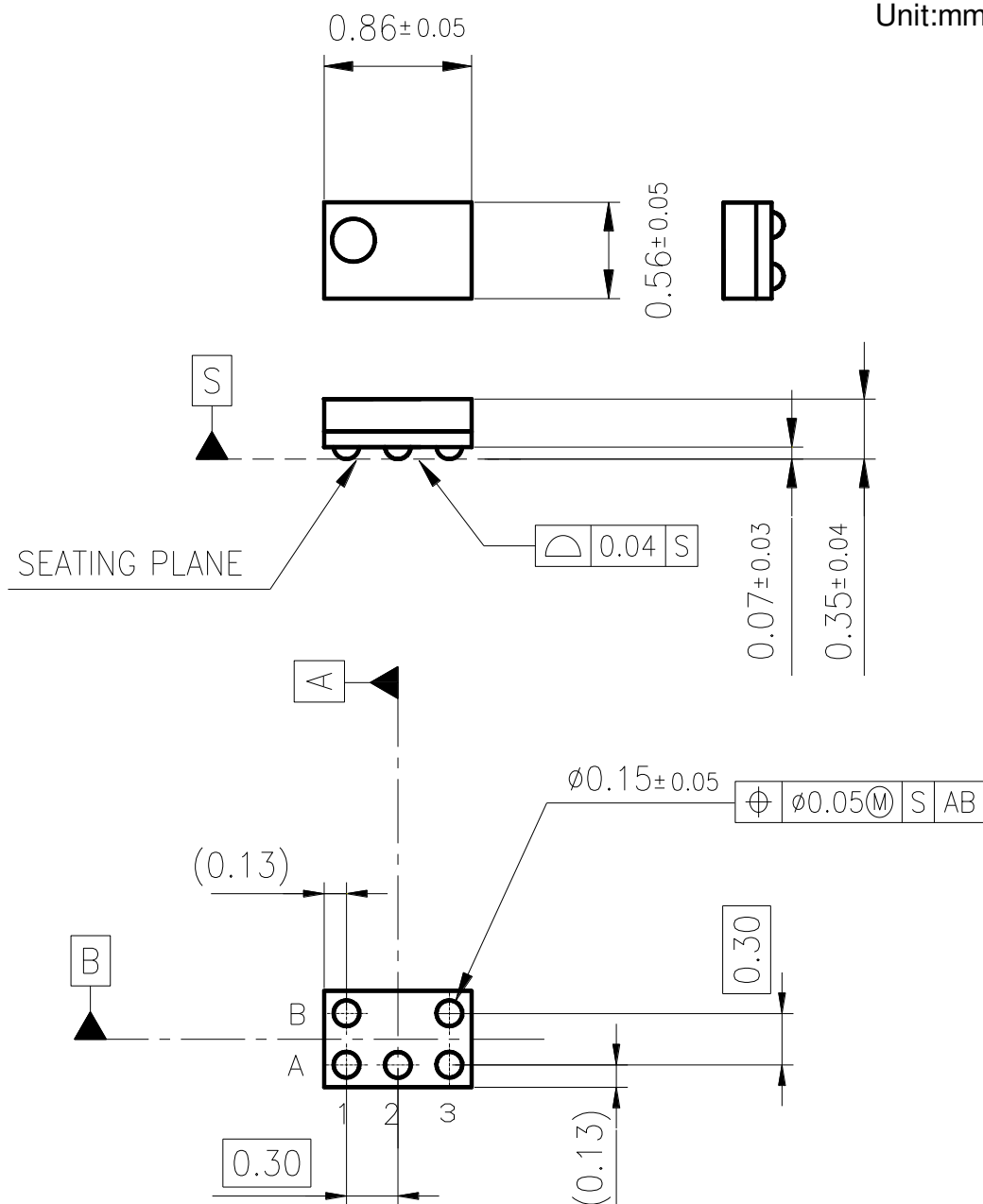

Body Material : Br/Sb Free Epoxy Resin
Reroute Material : Cu
Bump : SnAgCu

## IMPORTANT NOTICE

1. The products and product specifications described in this book are subject to change without notice for modification and/or improvement. At the final stage of your design, purchasing, or use of the products, therefore, ask for the most up-to-date Product Standards in advance to make sure that the latest specifications satisfy your requirements.
2. When using the LSI for new models, verify the safety including the long-term reliability for each product.
3. When the application system is designed by using this LSI, be sure to confirm notes in this book.  
Be sure to read the notes to descriptions and the usage notes in the book.
4. The technical information described in this book is intended only to show the main characteristics and application circuit examples of the products. No license is granted in and to any intellectual property right or other right owned by Panasonic Corporation or any other company. Therefore, no responsibility is assumed by our company as to the infringement upon any such right owned by any other company which may arise as a result of the use of technical information de-scribed in this book.
5. This book may be not reprinted or reproduced whether wholly or partially, without the prior written permission of our company.
6. This LSI is intended to be used for general electronic equipment [cellular phones].  
Consult our sales staff in advance for information on the following applications: Special applications in which exceptional quality and reliability are required, or if the failure or malfunction of this LSI may directly jeopardize life or harm the human body.  
Any applications other than the standard applications intended.
  - (1) Space appliance (such as artificial satellite, and rocket)
  - (2) Traffic control equipment (such as for automobile, airplane, train, and ship)
  - (3) Medical equipment for life support
  - (4) Submarine transponder
  - (5) Control equipment for power plant
  - (6) Disaster prevention and security device
  - (7) Weapon
  - (8) Others : Applications of which reliability equivalent to (1) to (7) is requiredIt is to be understood that our company shall not be held responsible for any damage incurred as a result of or in connection with your using the LSI described in this book for any special application, unless our company agrees to your using the LSI in this book for any special application.
7. This LSI is neither designed nor intended for use in automotive applications or environments unless the specific product is designated by our company as compliant with the ISO/TS 16949 requirements.  
Our company shall not be held responsible for any damage incurred by you or any third party as a result of or in connection with your using the LSI in automotive application, unless our company agrees to your using the LSI in this book for such application.
8. If any of the products or technical information described in this book is to be exported or provided to non-residents, the laws and regulations of the exporting country, especially, those with regard to security export control, must be observed.
9. Please use this product in compliance with all applicable laws and regulations that regulate the inclusion or use of controlled substances, including without limitation, the EU RoHS Directive. Our company shall not be held responsible for any damage incurred as a result of your using the LSI not complying with the applicable laws and regulations.

---

**USAGE NOTES**

1. When designing your equipment, comply with the range of absolute maximum rating and the guaranteed operating conditions (operating power supply voltage and operating environment etc.). Especially, please be careful not to exceed the range of absolute maximum rating on the transient state, such as power-on, power-off and mode-switching. Otherwise, we will not be liable for any defect which may arise later in your equipment.

Even when the products are used within the guaranteed values, take into the consideration of incidence of break down and failure mode, possible to occur to semiconductor products. Measures on the systems such as redundant design, arresting the spread of fire or preventing glitch are recommended in order to prevent physical injury, fire, social damages, for example, by using the products.

2. Comply with the instructions for use in order to prevent breakdown and characteristics change due to external factors (ESD, EOS, thermal stress and mechanical stress) at the time of handling, mounting or at customer's process. When using products for which damp-proof packing is required, satisfy the conditions, such as shelf life and the elapsed time since first opening the packages.
3. Pay attention to the direction of LSI. When mounting it in the wrong direction onto the PCB (printed-circuit-board), it might smoke or ignite.
4. Pay attention in the PCB (printed-circuit-board) pattern layout in order to prevent damage due to short circuit between pins. In addition, refer to the Pin Description for the pin configuration.
5. Perform a visual inspection on the PCB before applying power, otherwise damage might happen due to problems such as a solder-bridge between the pins of the semiconductor device. Also, perform a full technical verification on the assembly quality, because the same damage possibly can happen due to conductive substances, such as solder ball, that adhere to the LSI during transportation.
6. Take notice in the use of this product that it might break or occasionally smoke when an abnormal state occurs such as output pin-VCC short (Power supply fault), output pin-GND short (Ground fault), or output-to-output-pin short (load short) .

And, safety measures such as an installation of fuses are recommended because the extent of the above-mentioned damage and smoke emission will depend on the current capability of the power supply.

7. Due to unshielded structure of this LSI, under exposure of light, function and characteristic of the product cannot be guaranteed. During normal operation or even under testing condition, please ensure that LSI is not exposed to light.
8. Basically, chip surface is ground potential. Please design to ensure no contact between chip surface and metal shielding.