

## GLF2310, GLF2311, GLF2313, GLF2321 High Precision Programmable Current Limit Power Switch

### DESCRIPTION

The GLF2310, GLF2311, GLF2313 and GLF2321 are an advanced technology fully integrated power switch for applications required for precision output current limiting. The GLF2310, GLF2311, GLF2313 and GLF2321 feature also various protection functions such as under voltage lockout, true reverse current blocking (TRCB), short circuit protection, and thermal shutdown.

The GLF2310, GLF2311, GLF2313 and GLF2321 provide a built-in output voltage slew rate control to limit the inrush current and voltage surges. The FLGB output pin can be used to send a signal of fault events to the system controller. The integrated thermal shutdown (TSD) insures complete protection for the switch during output current limit and short circuit conditions. The GLF2310, GLF2311, GLF2313 and GLF2321 are an ideal switch for USB power supply.

### FEATURES

- Input Range: 2.5 V to 5.5 V
- Programmable Input Constant Limit Current (GLF2310A, GLF2311A)
  - Range: 40 mA - 2.1 A
- Fixed Output Constant Limit Current:
  - GLF2311B, GLF2313B: 2.1 A
  - GLF2321B: 1.8 A
- Low  $R_{ON}$ : 56 m $\Omega$  Typ. @ 5.0 V<sub>IN</sub>
- Ultra-Low  $I_Q$ : 20  $\mu$ A Typ. @ 5.0 V<sub>IN</sub>
- Ultra-Low  $I_{SD}$ : 50 nA Typ. @ 5.0 V<sub>IN</sub>
- Under Voltage Lockout Protection
- Output Voltage Slew Rate Controlled
- True Reverse Current Blocking Protection
- Short Circuit Protection
- Deglitched Fault Flag Indication at Over Current
  - Integrated Output Discharge Switch: GLF2311x, GLF2313x, GLF2321x
- Thermal Shutdown Protection
- SOT23 package
- IEC 62368-1:2018 CB Certification No. FI-52066

**PRODUCT TABLE**

Part Number	Top Mark	Current Limit ILIM	Output Discharge	Fault Flag FLGB	EN Activity	Package
GLF2310A-T1G7	FA	Programmable Output Current Limit Up to 2.1 A	NA	NA	High	SOT23-5L
GLF2311A-T1G7	FB		85 Ω	NA		SOT23-5L
GLF2310A-T2G7	HA		NA	Yes		SOT23-6L
GLF2311A-T2G7	HB		85 Ω	Yes		SOT23-6L
GLF2311B-T1G7	GB	Fixed Output Current Limit 2.1 A	85 Ω	Yes		SOT23-5L
GLF2313B-T1G7	KD	Fixed 2.1 A	85 Ω	Yes	Low	SOT23-5L
GLF2321B-T1G7	KB	Fixed Output Current Limit 1.8 A	85 Ω	Yes	High	SOT23-5L

**EVALUATION BOARD, DEVICE PACKAGE, AND PINOUT**

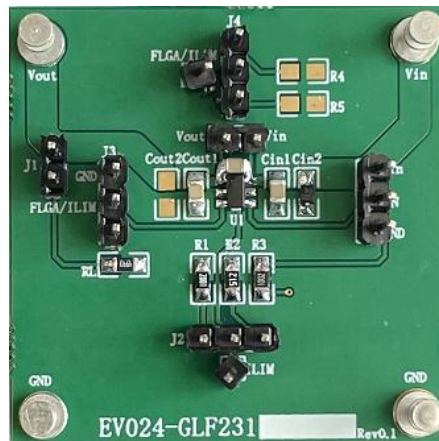

## GLF2310A-T1G7, GLF2311A-T1G7

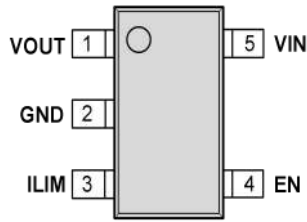

Pin #	Name	Description
1	VOUT	Switch output
2	GND	Ground
3	ILIM	Programmable current limit. Do not leave this pin floating.
4	EN	Active high switch output enables to control the switch
5	VIN	Switch Input. Supply voltage for IC

## GLF2310A-T2G7, GLF2311A-T2G7

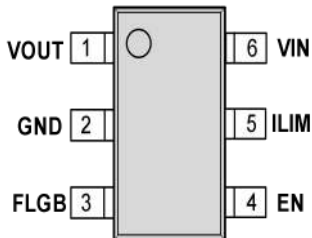

Pin #	Name	Description
1	V <sub>OUT</sub>	Switch output
2	GND	Ground
3	FLGB	Flag pin goes low to indicate OCP, SC, RCB, and TSD fault conditions
4	EN	Active high switch output enables to control the switch
5	ILIM	Programmable current limit Do not leave this pin floating.
6	VIN	Switch Input. Supply voltage for IC

## GLF2311B-T1G7, GLF2313B-T1G7, GLF2321B-T1G7

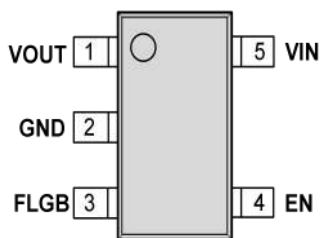

Pin #	Name	Description
1	V <sub>OUT</sub>	Switch Output
2	GND	Ground
3	FLGB	Flag pin goes low to indicate OCP, SC, RCB, and TSD fault conditions
4	EN	Active high switch output enables to control the switch Active low: GLF2313B
5	VIN	Switch Input. Supply voltage for IC

## QUICK START GUIDE

1. The evaluation board EV024 is easy to set up to evaluate the performance of GLF2310/ GLF2311/ GLF2313/ GLF2321. Preset the input power supply to the desired voltage between 2.5 V to 5.5 V.

2. The load resistor,  $R_L=499 \Omega$ , has been populated on the top of the PCB board. Short the J1 to use the  $R_L$ . To increase the output current, connect an electronic load to VOUT and GND. The GLF2310/ GLF2311/ GLF2313 is rated for 2.1 A maximum continuous output current and the GLF2321 is rated for 1.8 A maximum continuous output current. Please ensure the absolute maximum is not exceeded.

3. Connect the positive and negative terminals of the input power supply to VIN

and GND terminals respectively. VIN\_Sense and VOUT\_Sense can be used for measurement points.

4. When using GLF2310A-T1G7 and GLF2311A-T1G7, you can program the OCP: short #2 pin (J3) to #2 pin (J2), and then short #2 pin(J2) to #3 pin (J2), will enable R1, when short #1 pin (J2) and #2 pin (J2), R2 will be enabled.

5. When using GLF2311B-T1G7, GLF2313B-T1G7 and GLF2321B-T1G7, you can: Short the #1 pin (J3) to #2 pin (J3) to observe the FLGB signal. At the moment, #2 pin (J3) cannot be connected to #2 pin (J2).

6. Turn on the input power supply. Connect EN to Vin (to GND for GLF2313) with a jumper, and VOUT will be turned on.

## TEST SETUP



## SCHEMATIC

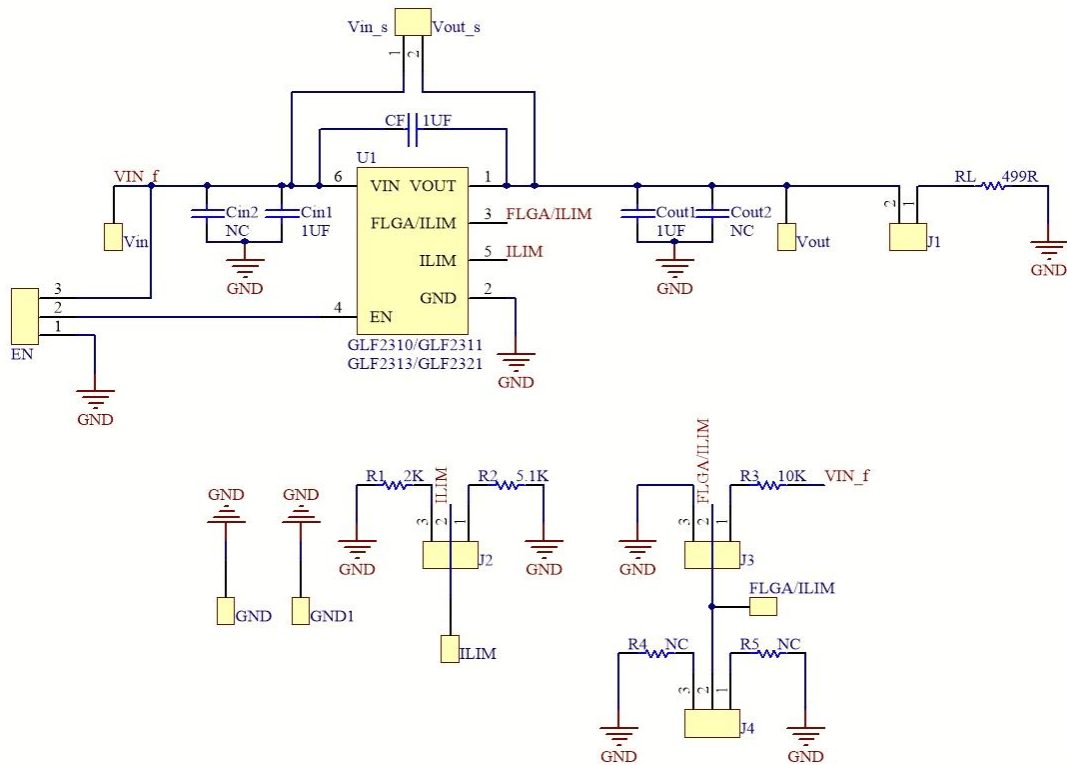

## BILL OF MATERIALS

Qty	Reference	Value	Part Description	Manufacturer/Part Number
1	U1	GLF2310/ GLF2311/ GLF2313/ GLF2321	Current Limit Power Switch	GLF Integrated Power
3	Cin1, Cout1, C <sub>F</sub>	1 μF	Cap., X7R, 1 μF, 50 V, ± 10%, 0805	Yageo/CC0805KRX7R9 BB105
1	R1	2 KΩ	Res., RC, 200 Ω, 1/8W, ± 1%, 0805	Yageo/RC0805FR-07200RL
1	R2	5.1 KΩ	Res., RC, 2 KΩ, 1/8W, ± 1%, 0805	Yageo/RC0805FR-072K0RL
1	R3	10 KΩ	Res., RC, 10 KΩ, 1/8W, ± 1%, 0805	Yageo/RC0805FR-0710KRL
1	RL	499 Ω	Load Resistor	YAGEO RC0805FR-07499RL
2	J2, J3	Jumper	Jumper, 2.54 mm, 3 PIN	-
1	J1	Jumper	Jumper, 2.54 mm, 2 PIN	-
4	VIN, VOUT, GND	-	1514-2	-

**PRINTED CIRCUIT BOARD LAYOUT**

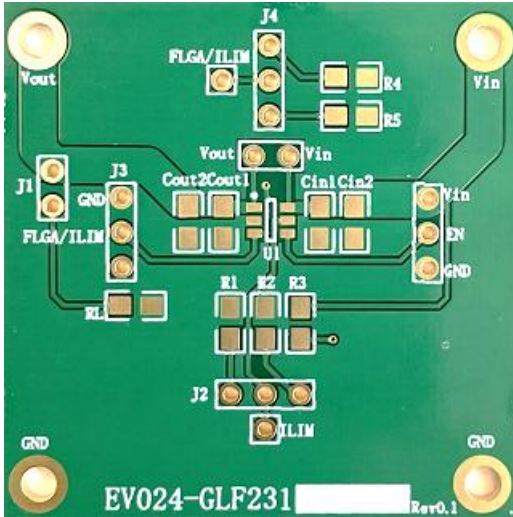

Fig 1. Top Layer

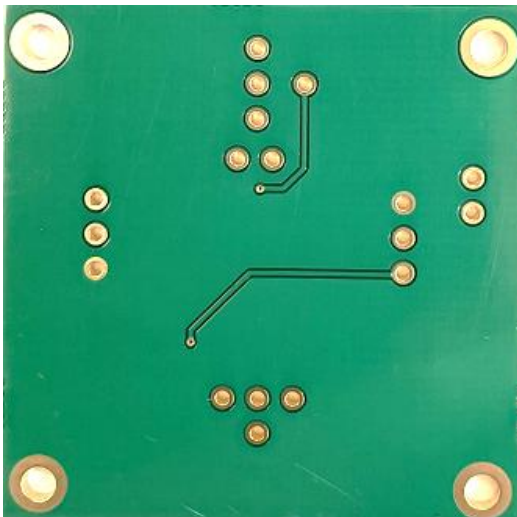

Fig 2. Bottom Layer

NOTICE: The evaluation board provided by GLF Integrated Power is intended for use for ENGINEERING DEVELOPMENT, OR EVALUATION PURPOSES ONLY and is not for any commercial use. The user assumes all responsibility and liability for proper and safe handling of the goods.