

PIC32MX XLP Starter Kit Information Sheet

Thank you for purchasing the Microchip PIC32MX XLP Family Starter Kit, DM320105. This information sheet highlights some important details that will help you successfully use the board as quickly as possible.

Features

The PIC32MX XLP Starter Kit (DM320105) provides a low-cost method for development and testing of the XLP applications with the PIC32MX274F256D device.

The PIC32MX XLP Starter Kit includes the following:

- A standard A-to-B Micro-USB cable for the debugger
- A 9-axis IMU
- A light sensor
- A low-power BTLE radio
- Five user-configurable buttons
- A high-intensity CREE LED
- A 2x AA battery holder

Installing MPLAB® IDE and C Compilers

The MPLAB Integrated Development Environment (IDE) should be installed prior to using the PIC32MX XLP Starter Kit. While MPLAB IDE provides the assembler tools for development, the Microchip demonstration code requires installation of a C Compiler. Microchip's MPLAB C Compiler seamlessly integrates into MPLAB IDE. Both the MPLAB IDE and MPLAB C Compiler are free and are available for download from the Microchip web site: www.microchip.com/MPLAB and www.microchip.com/compilers.

Note: Standard Evaluation (Free) – All optimization levels are enabled for 60 days, but then revert to optimization level 1 only.

Microchip Demonstration Code and More Information

For the free Microchip demonstration code, please visit the MPLAB Harmony page at www.microchip.com/harmony. For additional information, please visit the PIC32MX XLP Starter Kit page at www.microchip.com.

Americas

Atlanta - 678-957-9614
Austin - 512-257-3370
Boston - 774-760-0087
Chicago - 630-285-0071
Cleveland - 216-447-0464
Dallas - 972-818-7423
Detroit - 248-848-4000
Houston - 281-894-5983
Indianapolis - 317-773-8323
Los Angeles - 949-462-9523
New York - 631-435-6000
Phoenix - 480-792-7200
Santa Clara - 408-961-6444
Toronto - 905-673-0699

Europe

Austria - Wels - 43-7242-2244-39
Denmark - Copenhagen - 45-4450-2828
France - Paris - 33-1-69-53-63-20
Germany - Munich - 49-89-627-144-0
Italy - Milan - 39-0331-742611
Netherlands - Drunen - 31-416-690399
Spain - Madrid - 34-91-708-08-90
UK - Wokingham - 44-118-921-5869

Asia/Pacific

Australia - Sydney - 61-2-9868-6733
China - Beijing - 86-10-8569-2100

Asia/Pacific (Continued)

China - Chengdu - 86-28-8665-5511
China - Chongqing - 86-23-8980-9588
China - Hangzhou - 86-571-8792-8115
China - Hong Kong SAR - 852-2943-5100
China - Nanjing - 86-25-8473-2460
China - Qingdao - 86-532-8502-7355
China - Shanghai - 86-21-5407-5533
China - Shenyang - 86-24-2334-2829
China - Shenzhen - 86-755-8864-2200
China - Wuhan - 86-27-5980-5300
China - Xiamen - 86-592-2388138
China - Xian - 86-29-8833-7252
China - Zhuhai - 86-756-3210040
India - Bangalore - 91-80-3090-4444
India - New Delhi - 91-11-4160-8631
India - Pune - 91-20-3019-1500
Japan - Osaka - 81-6-6152-7160
Japan - Tokyo - 81-3-6880-3770
Korea - Daegu - 82-53-744-4301
Korea - Seoul - 82-2-554-7200
Malaysia - Kuala Lumpur - 60-3-6201-9857
Malaysia - Penang - 60-4-227-8870
Philippines - Manila - 63-2-634-9065
Singapore - 65-6334-8870
Taiwan - Hsin Chu - 886-3-5778-366
Taiwan - Kaohsiung - 886-7-213-7840
Taiwan - Taipei - 886-2-2508-8600
Thailand - Bangkok - 66-2-694-1351

03/23/17



MICROCHIP

Microchip Technology Inc. • 2355 West Chandler Blvd. • Chandler, AZ 85224-6199

www.microchip.com

The Microchip name and logo, the Microchip logo, and MPLAB are registered trademarks of Microchip Technology Incorporated in the U.S.A. and other countries. All other trademarks mentioned herein are property of their respective companies. © 2014, Microchip Technology Incorporated, Printed in the U.S.A. All Rights Reserved. 03/14

DS50002595A



PIC32MX XLP Starter Kit Schematics (1 of 4)

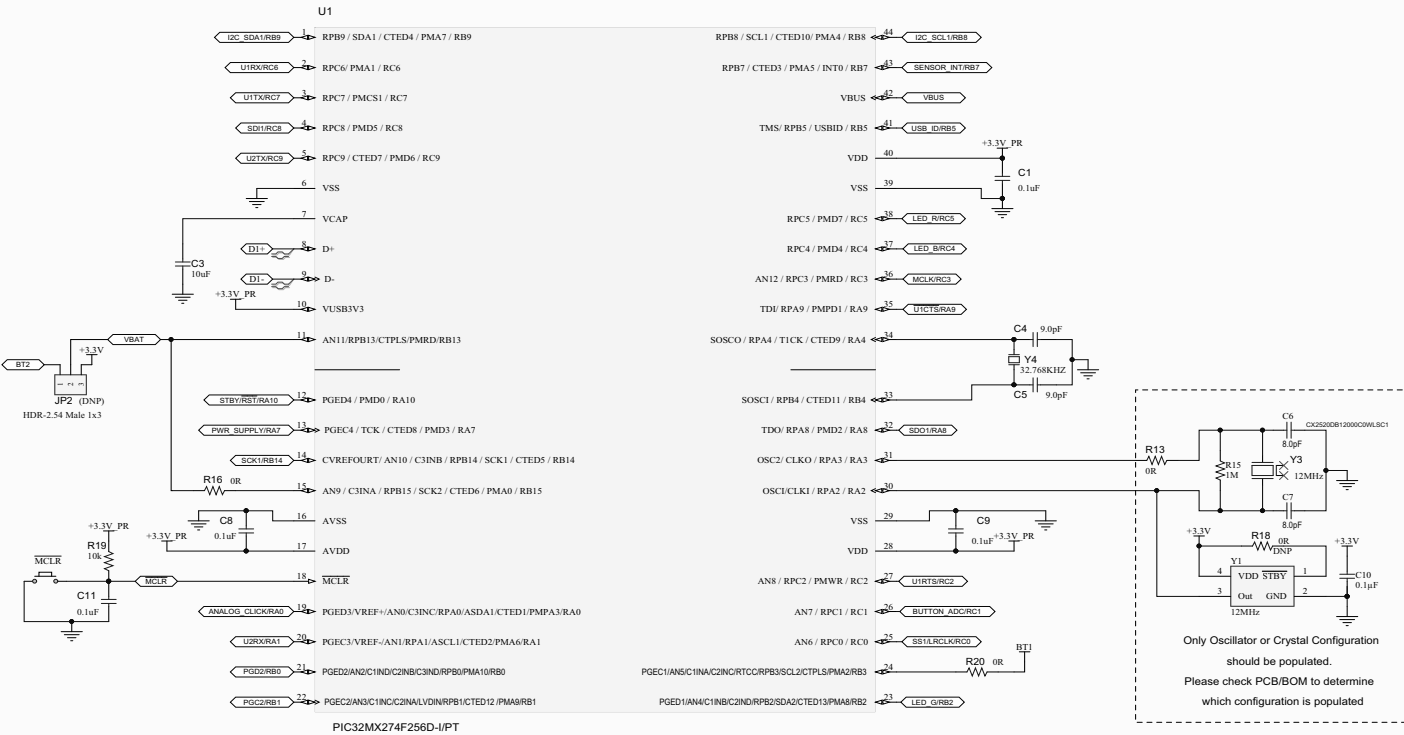
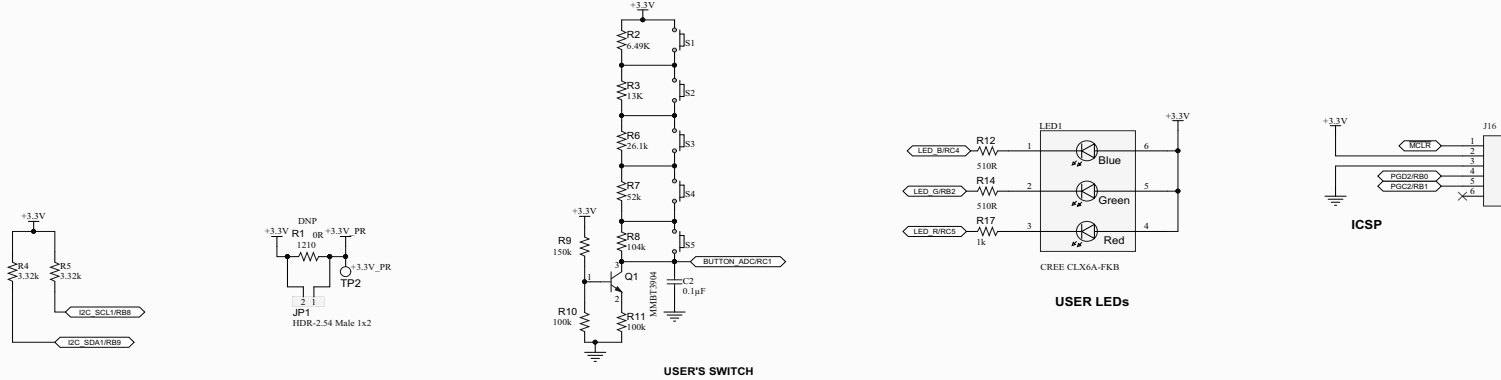

Mounting Holes



PIC32MX XLP Starter Kit Schematics (2 of 4)

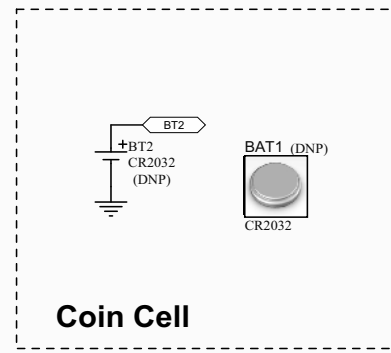
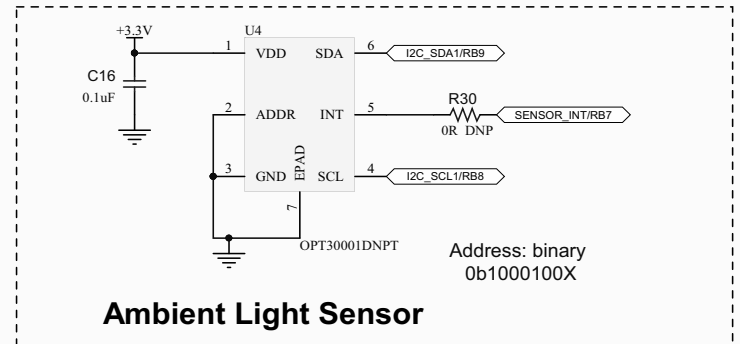
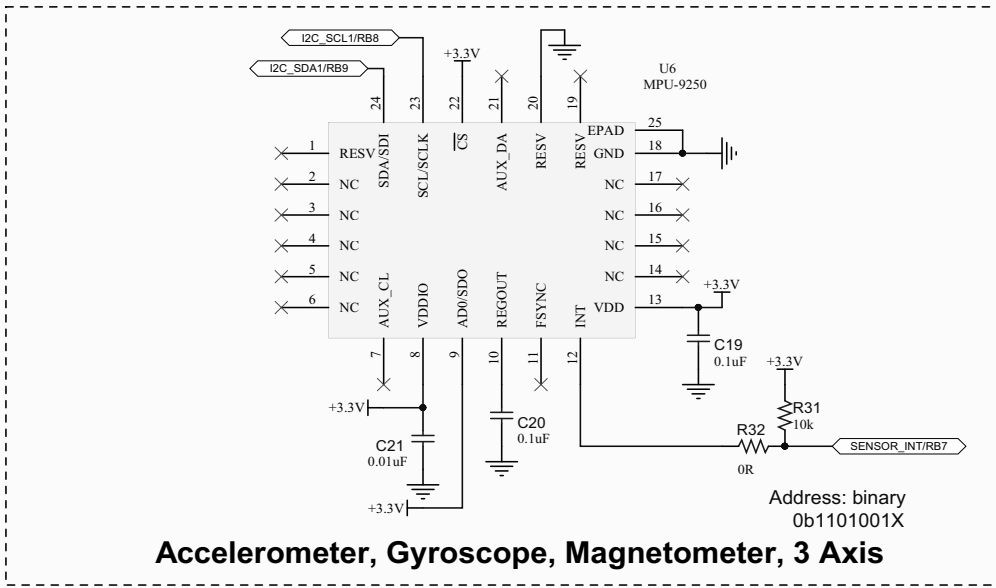
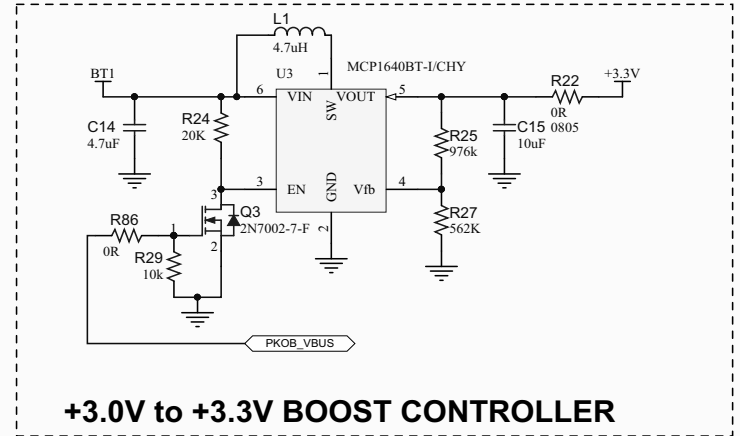
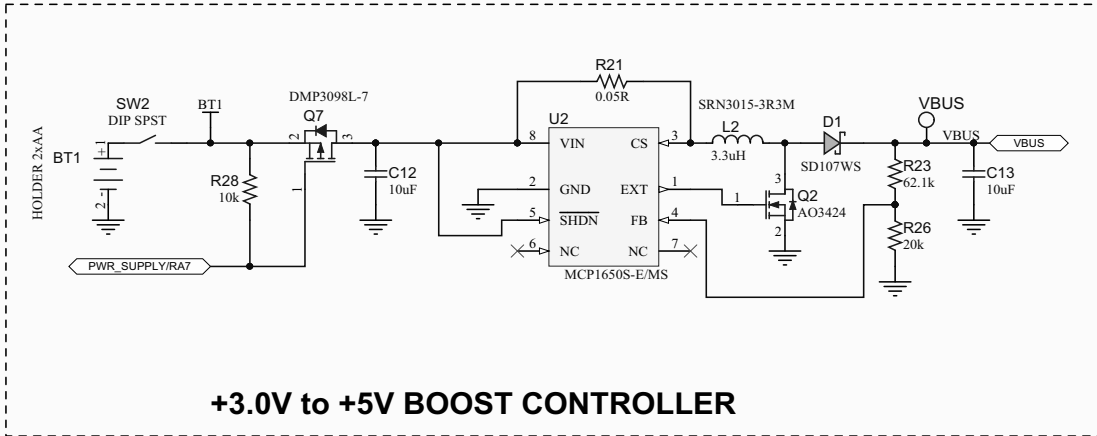

PIC32MX XLP Starter Kit Schematics (3 of 4)

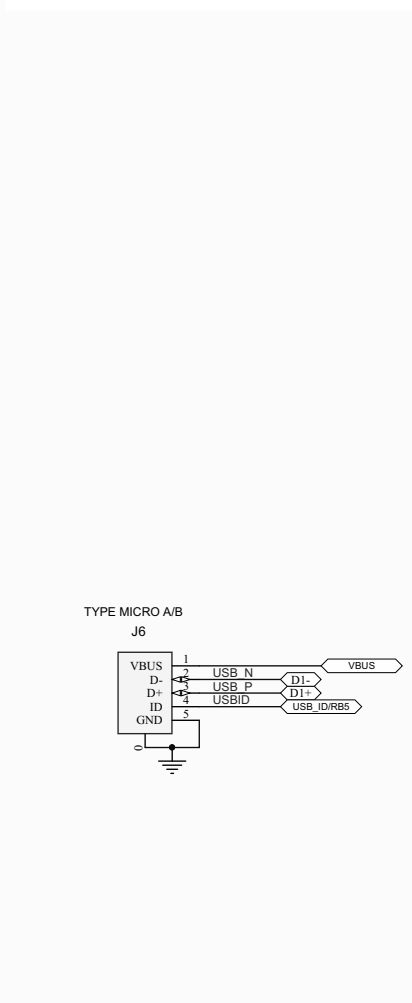
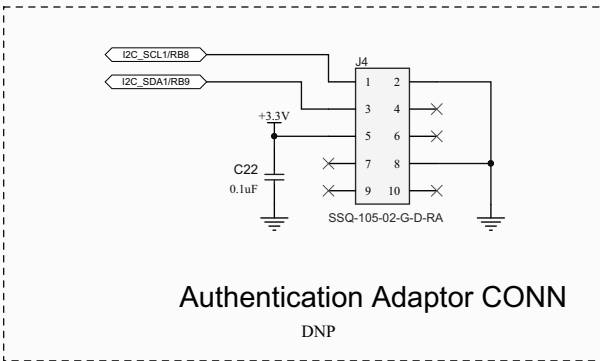
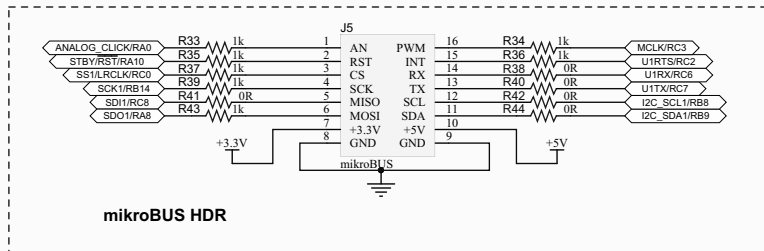
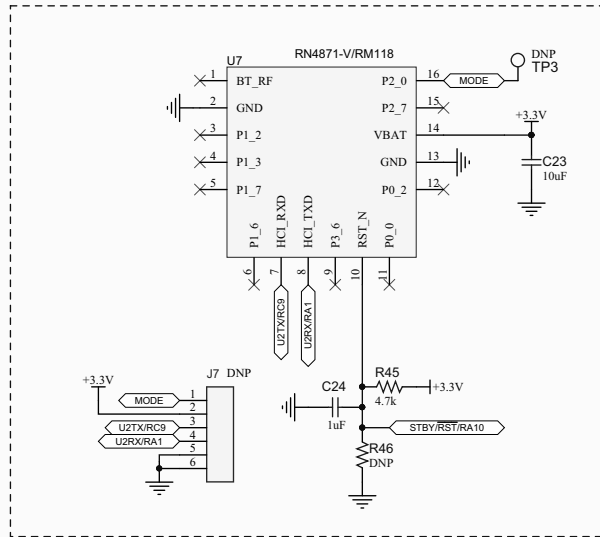
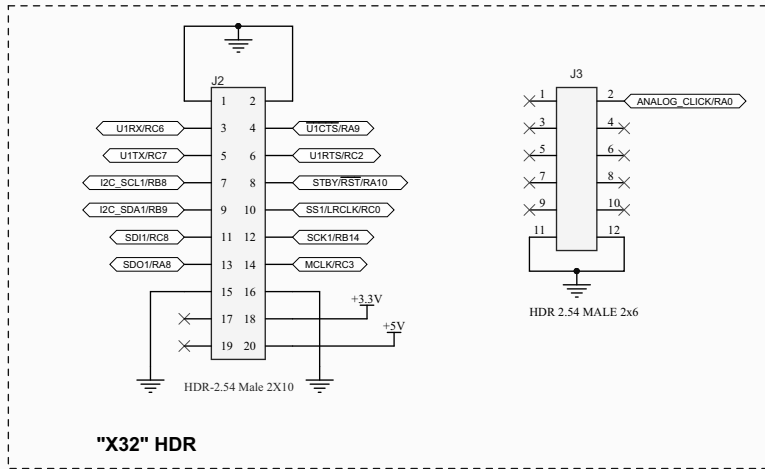

PIC32MX XLP Starter Kit Schematics (4 of 4)

