

REVISIONS					
P.	LTN	DESCRIPTION	DATE	DMN	APVD
P	REV PER ECO	17-012106	8-22-17	CT	DM

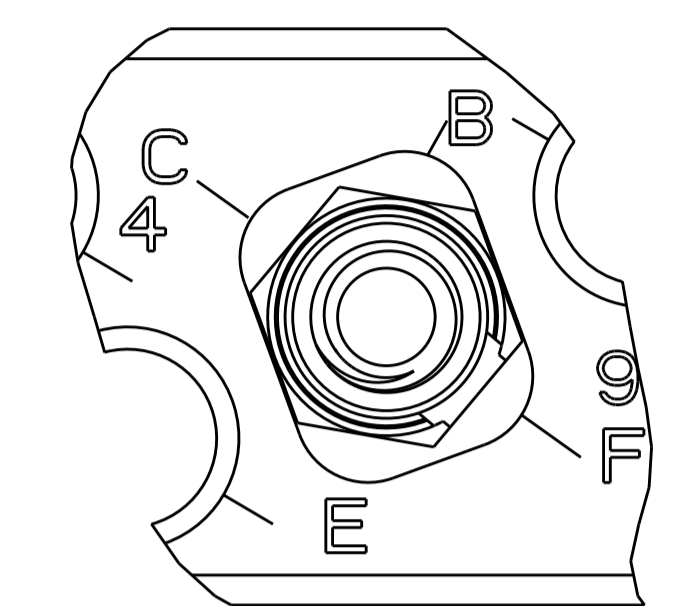

JACKSCREW POLARIZATION "F" SHOWN  
SCALE 4:1

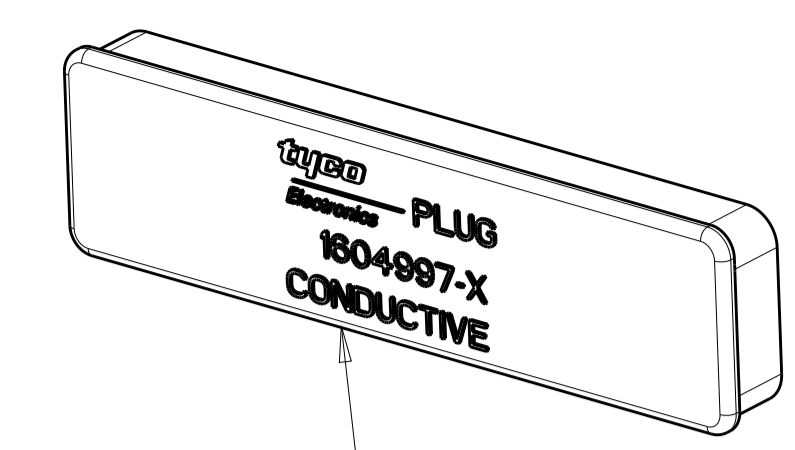
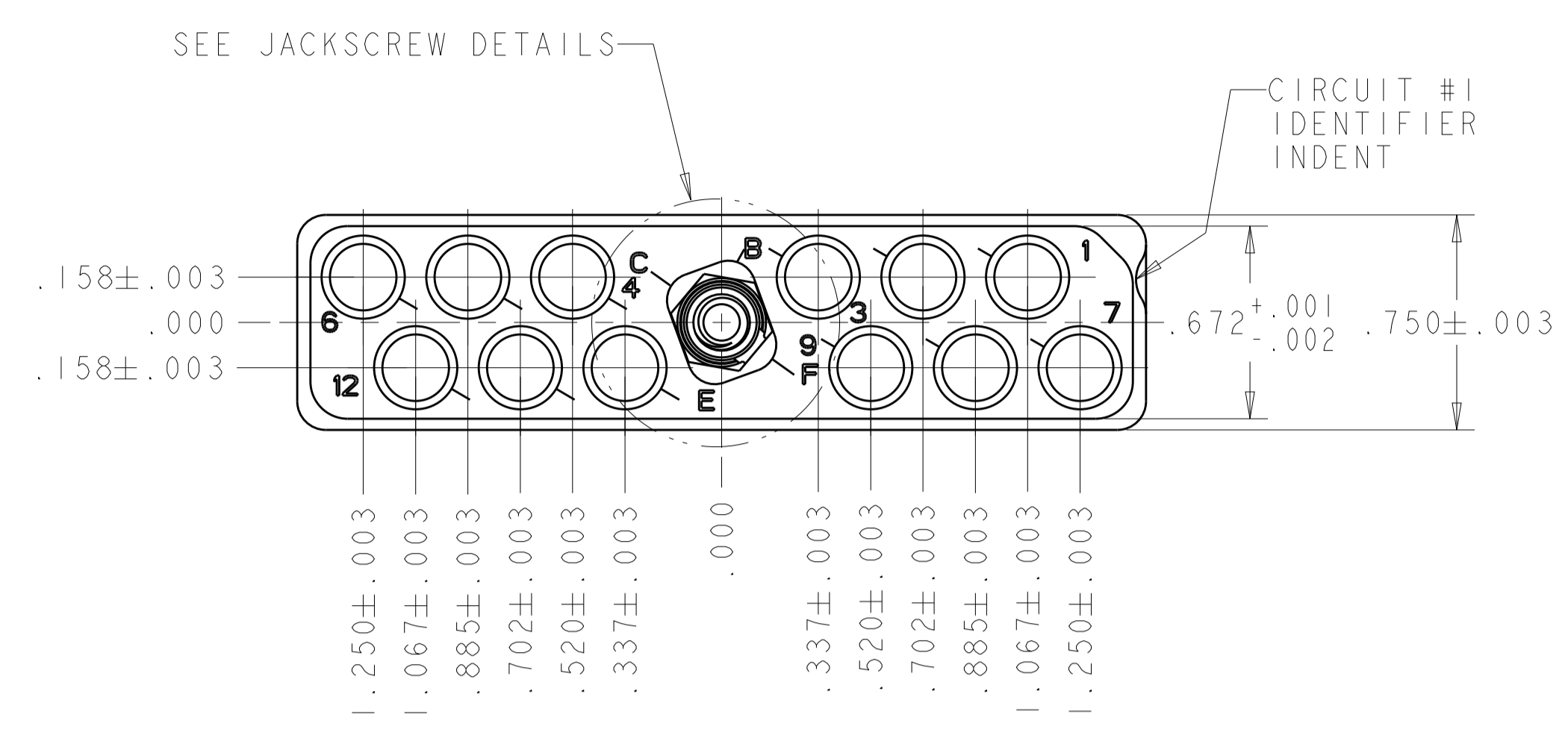
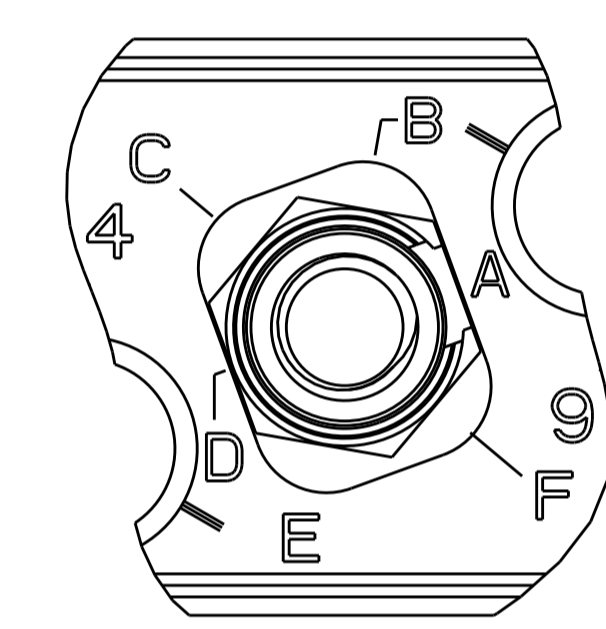
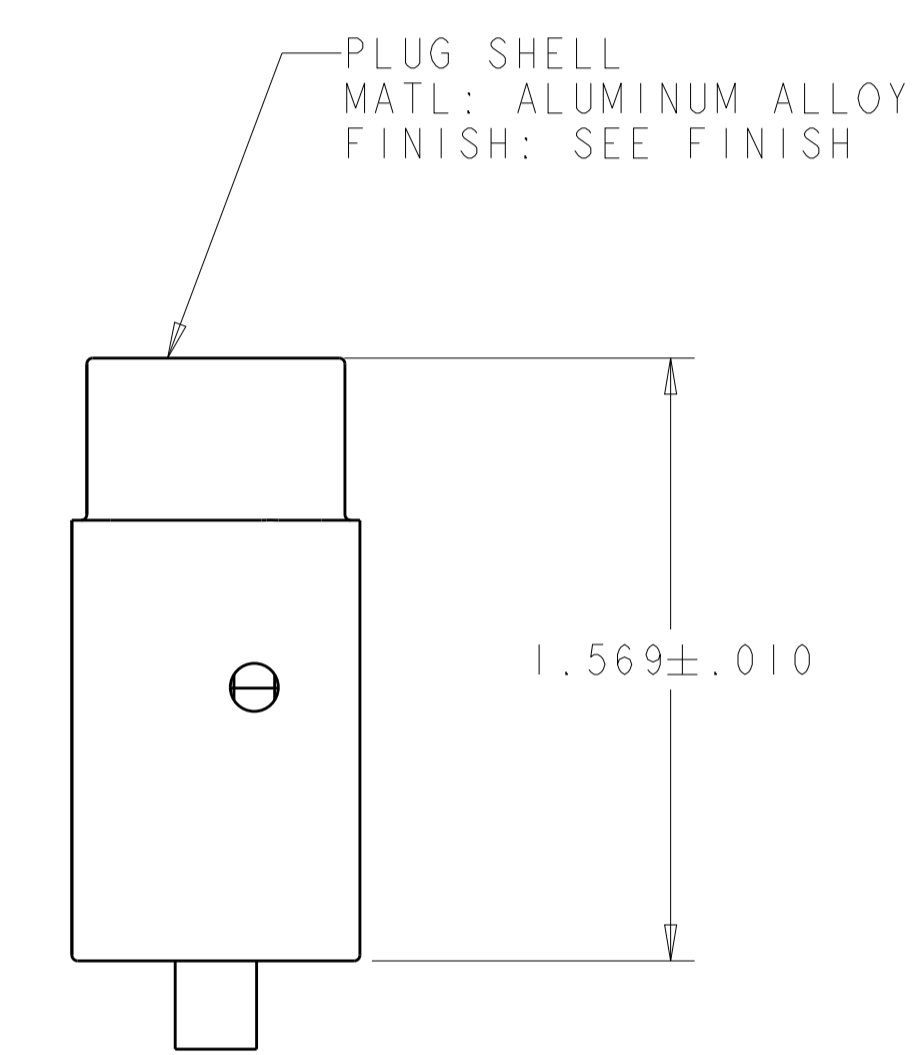
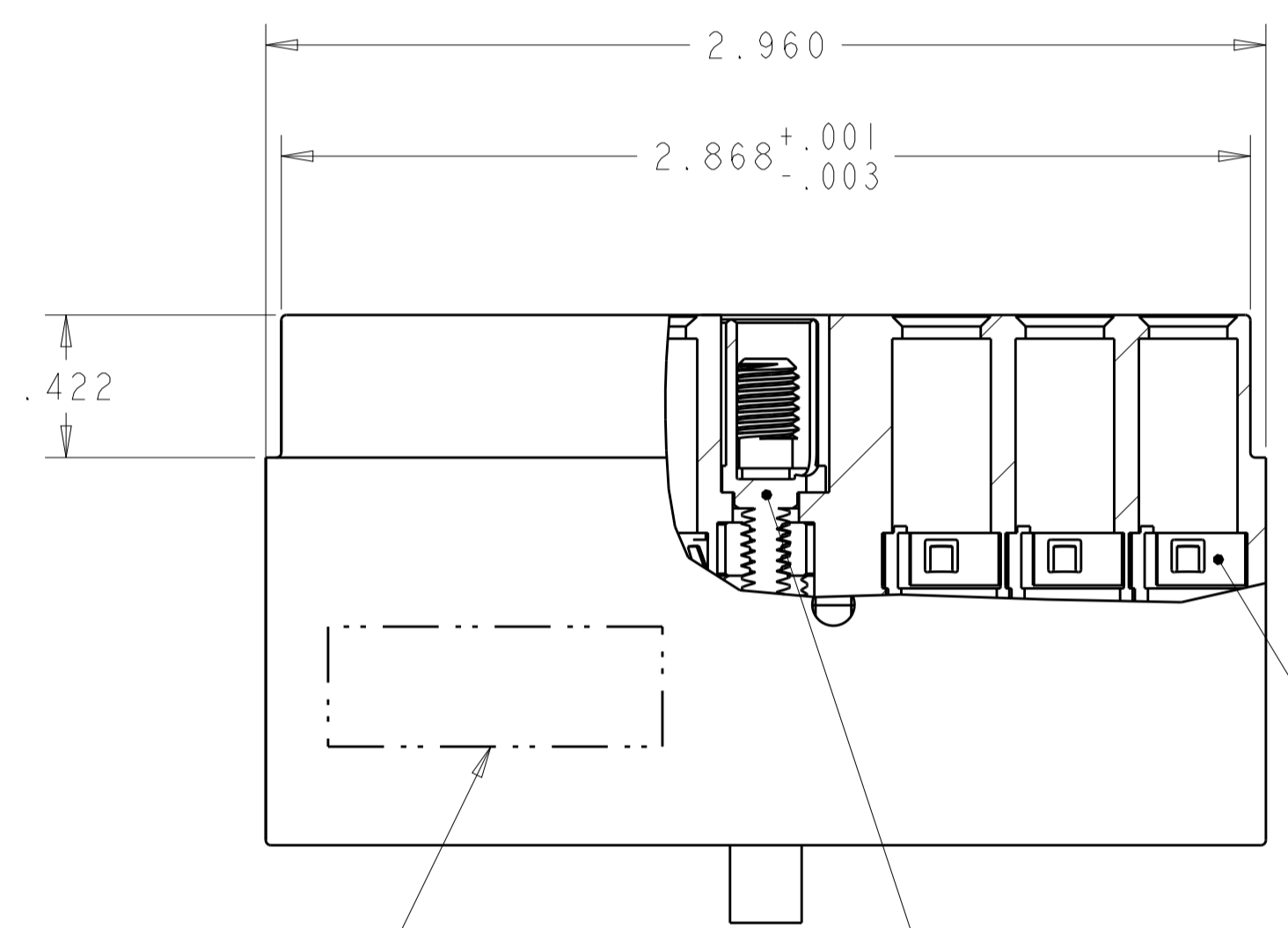

JACKSCREW POLARIZATION "A" SHOWN  
SCALE 4:1

TE LOGO, DATE CODE AND EITHER CUSTOMER OR TE PART NUMBER (PER TABLE), CAGE CODE 00779 (-6 ONLY) MARKED APPROX AS SHOWN ON NEAR OR FAR SIDE)

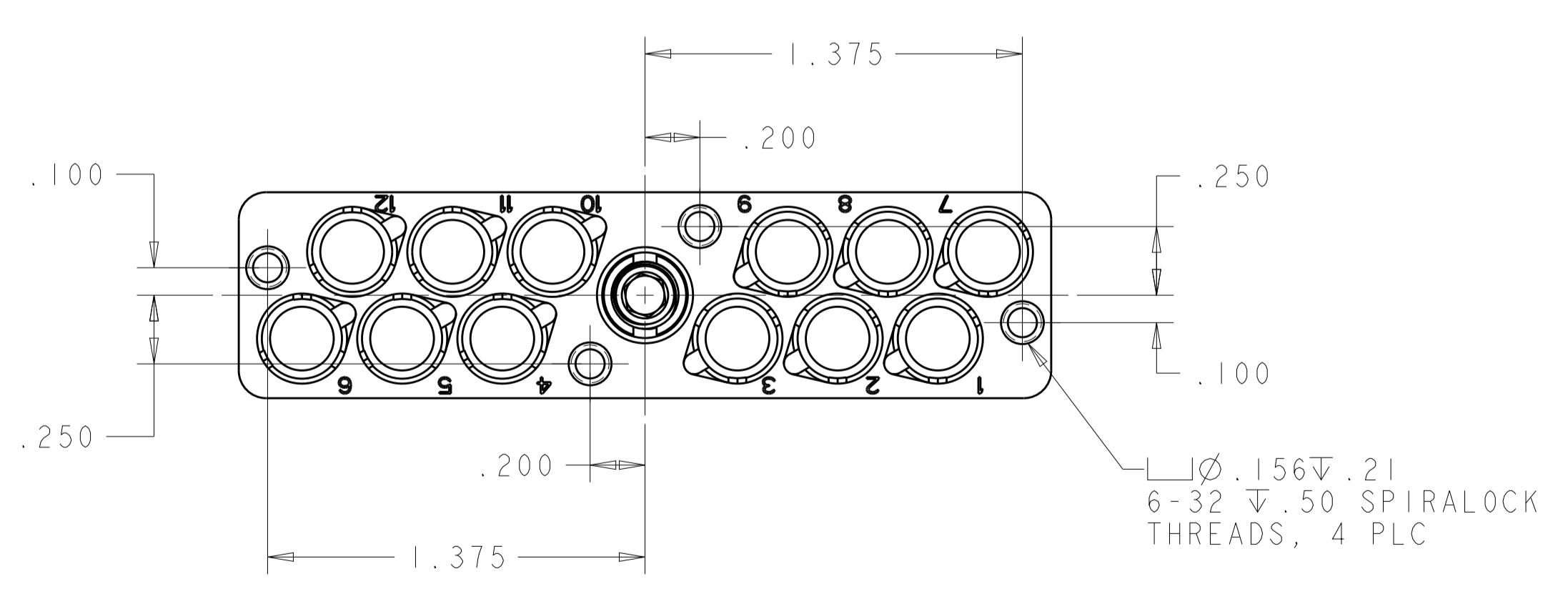

SUPERSEDED BY 1604800-5

**OBSOLETE**

ELECTROLESS NICKEL	1445693-4	BACC65BC12ND	JACKSCREW ASSEMBLED PLZLN CODE D	1-1604800-5
ELECTROLESS NICKEL	1445693-4	BACC65BC12N	WITH JACKSCREW-RETENTION NUT KIT	1-1604800-4
ELECTROLESS NICKEL	1445693-4	BACC65BC12NE	JACKSCREW ASSEMBLED PLZLN CODE E	1-1604800-3
ELECTROLESS NICKEL	1445693-4	BACC65BC12NC	JACKSCREW ASSEMBLED PLZLN CODE C	1-1604800-2
ELECTROLESS NICKEL	1445693-4	BACC65BC12NB	JACKSCREW ASSEMBLED PLZLN CODE B	1-1604800-1
ELECTROLESS NICKEL	1445693-4	BACC65BC12NF	JACKSCREW ASSEMBLED PLZLN CODE F	1-1604800-0
ELECTROLESS NICKEL	1445693-4	BACC65BC12NA	JACKSCREW ASSEMBLED PLZLN CODE A	1604800-9
ELECTROLESS NICKEL	1445693-3	---	WITH JACKSCREW-RETENTION NUT KIT	1604800-8
ELECTROLESS NICKEL	1445693-3	---	JACKSCREW ASSEMBLED PLZLN CODE A	1604800-6
ELECTROLESS NICKEL	1445693-3	---	WITH JACKSCREW-RETENTION NUT KIT	1604800-5
BLACK ANODIZED	1445693-4	BACC65BC12A	WITH JACKSCREW-RETENTION NUT KIT	1604800-4
SHELL FINISH	RECOMMENDED CONTACT WITH WIRE SEAL	BOEING PART NUMBER	DESCRIPTION	PART NO.

⚠ JACKSCREW-RETENTION NUT KIT IS UNASSEMBLED TO CONNECTOR ASSY. KIT IS PACKAGED IN SEALED BAG.

THIS DRAWING IS A CONTROLLED DOCUMENT.		DMN: Brent D. Lohm 24 JUNE 2004	TE Connectivity
DIMENSIONS: IN		CHK: W.H. BERNHART 24 JUNE 2004	
TOLERANCES UNLESS OTHERWISE SPECIFIED:		APVD: W.H. BERNHART 24 JUNE 2004	NAME: PLUG ASSEMBLY, QUADRAX, FREE HANGING, RR/RR, 12 POSITION PRODUCT SPEC: - APPLICATION SPEC: -
0 PLC ± 1 PLC ± 2 PLC ± 3 PLC ±.005 4 PLC ± ANGLES ±1°		SIZE: CAGE CODE DRAWING NO: A100779C=1604800 WEIGHT: - CUSTOMER DRAWING: -	
MATERIAL: SEE CALLOUTS		RESTRICTED TO: - SCALE: 2:1 SHEET 1 OF 1 REV P	