

DRAWING NO.

D1021-543

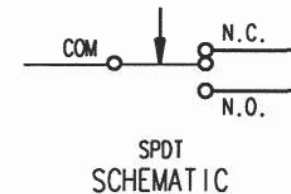
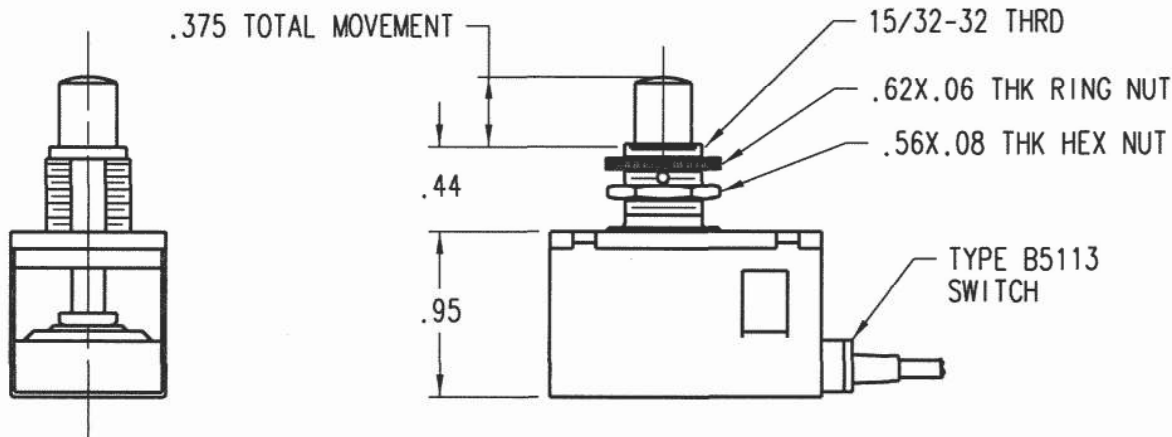
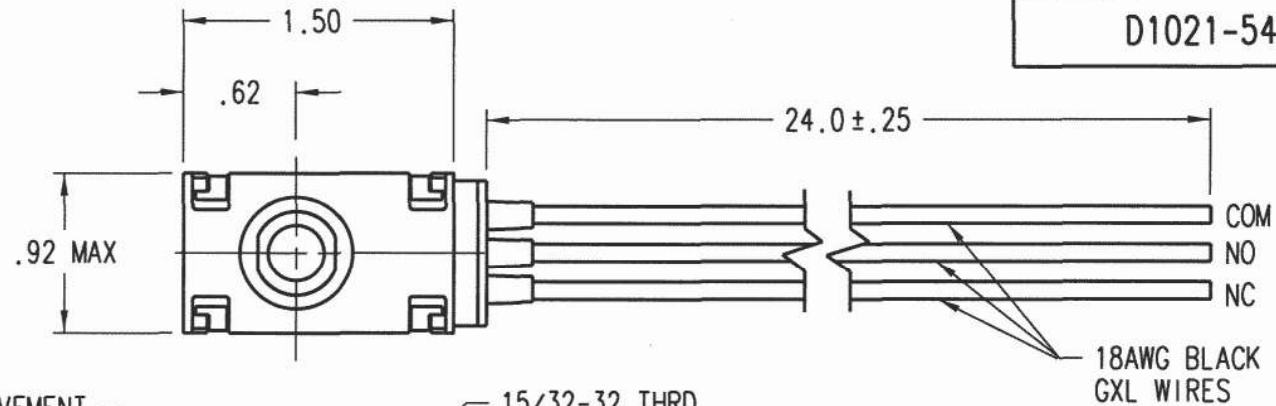

NOTES:

1. STAINLESS STEEL CASE, THERMOPLASTIC COVER, MOUNTING BUSHING, AND PUSHBUTTON.
2. INCLUDES ONE HEX NUT AND ONE RING NUT FOR EACH SWITCH.
3. SWITCH IS COMPLETELY WATERPROOF.
4. WIRE CONNECTIONS MUST BE SEALED TO MAINTAIN THE WATERPROOFNESS OF THE SWITCH.
5. SWITCH ACTION: SPDT
6. ELECTRICAL RATING (28VDC/120VAC): 5 AMP RESISTIVE, 3 AMPS INDUCTIVE.
7. PROPER APPLICATION OF THIS PRODUCT IS THE RESPONSIBILITY OF THE USER.

REV	DESCRIPTION	DATE	BY	APP	UNLESS OTHERWISE SPECIFIED DIMENSIONS ARE IN INCHES		APPROVALS		DATE	CPI CONTROL PRODUCTS, INC. EAST HANOVER, NEW JERSEY WWW.CPI-NJ.COM								
					TOLERANCES ARE:		DRAWN	GHS	7/27/21	TITLE WATERPROOF PUSHBUTTON SWITCH INSTALLATION DRAWING								
					.X ± .1 .XX ± .03 .XXX ± .015 ANG ± 5°		CHECKED											
REVISIONS					MATERIAL		ISSUED	ECN7184	ROG	7/27/21	SIZE A		SCALE NONE		DRAWING NO. D1021-543		SHEET 1 OF 1	
THE INFORMATION FURNISHED HEREIN IS THE PROPERTY OF CONTROL PRODUCTS, INC. AND SHALL NOT BE USED, DISCLOSED TO OTHERS, OR COPIED WITHOUT THE EXPRESS WRITTEN CONSENT OF CONTROL PRODUCTS, INC.					FINISH AND HEAT TREAT		DIGI-KEY											
							DO NOT SCALE DRAWING											