

## SINGLE-CHIP USB TO UART BRIDGE

### Single-Chip USB to UART Data Transfer

- Integrated USB transceiver; no external resistors required
- Integrated clock; no external crystal required
- Integrated 1024-Byte EEPROM for vendor ID, product ID, serial number, power descriptor, release number, and product description strings
- On-chip power-on reset circuit
- On-chip voltage regulator: 3.3 V output

### USB Function Controller

- USB Specification 2.0 compliant; full-speed (12 Mbps)
- USB suspend states supported via SUSPEND pins

### Asynchronous Serial Data BUS (UART)

- All handshaking and modem interface signals
- Data formats supported:
  - Data bits: 5, 6, 7, and 8
  - Stop bits: 1, 1.5, and 2
  - Parity: odd, even, mark, space, no parity
- Baud rates: 300 bps to 1 Mbps
- 576 Byte receive buffer; 640 byte transmit buffer
- Hardware or X-On/X-Off handshaking supported
- Four GPIO signals for status and control
- Configurable I/O (1.8 V to V<sub>DD</sub>) using V<sub>IO</sub> pin
- Configurable I/O (V<sub>DD</sub> to 5 V) using external pull-up
- RS-485 mode with bus transceiver control

### Virtual COM Port Device Drivers

- Works with Existing COM Port PC Applications
- Royalty-Free Distribution License
- Windows 7<sup>®</sup>/Vista<sup>®</sup>/XP<sup>®</sup>/Server 2003<sup>®</sup>/2000<sup>®</sup>
- Mac<sup>®</sup> OS-X
- Linux

### USBXpress™ Direct Driver Support

- Royalty-Free Distribution License
- Windows 7/Vista/XP/Server 2003/2000
- Windows CE 6.0, 5.0, and 4.2

### Example Applications

- Upgrade of RS-232 legacy devices to USB
- Upgrade of RS-485 legacy devices to USB
- Cellular phone USB interface cable
- PDA USB interface cable
- USB to RS-232 serial adapter

### Supply Voltage

- Self-powered: 3.0 to 3.6 V
- USB bus powered: 4.0 to 5.25 V
- I/O voltage: 1.8 V to V<sub>DD</sub>

### Package

- Lead free 28-pin QFN (5x5 mm)

### Ordering Part Number

- CP2103-GM

**Temperature Range: -40 to +85 °C**

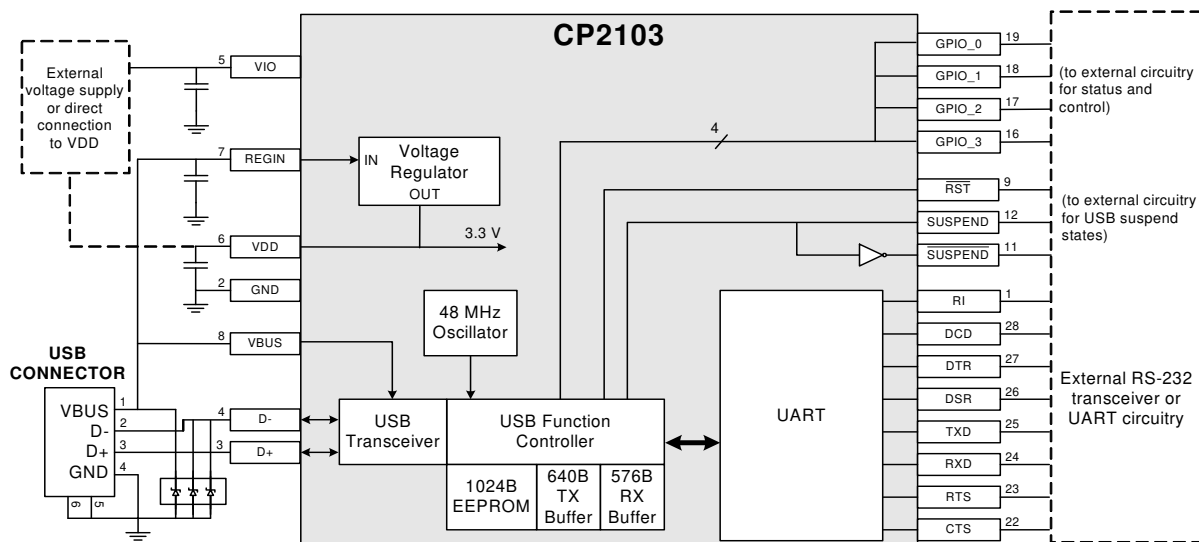

**Figure 1. Example System Diagram**



---

**TABLE OF CONTENTS**

---

<b><u>Section</u></b>	<b><u>Page</u></b>
<b>1. System Overview</b> .....	<b>4</b>
<b>2. Electrical Specifications</b> .....	<b>5</b>
<b>3. Pinout and Package Definitions</b> .....	<b>8</b>
<b>4. USB Function Controller and Transceiver</b> .....	<b>13</b>
<b>5. Asynchronous Serial Data Bus (UART) Interface</b> .....	<b>14</b>
<b>6. GPIO Pins</b> .....	<b>14</b>
<b>7. Internal EEPROM</b> .....	<b>14</b>
<b>8. CP2103 Device Drivers</b> .....	<b>15</b>
8.1. Virtual COM Port Drivers .....	15
8.2. USBXpress Drivers .....	15
8.3. Driver Customization .....	15
8.4. Driver Certification .....	15
<b>9. Voltage Regulator</b> .....	<b>16</b>
<b>10. Relevant Application Notes</b> .....	<b>18</b>
<b>Document Change List</b> .....	<b>19</b>
<b>Contact Information</b> .....	<b>20</b>

## 1. System Overview

The CP2103 is a highly-integrated USB-to-UART Bridge Controller providing a simple solution for updating RS-232/RS-485 designs to USB using a minimum of components and PCB space. The CP2103 includes a USB 2.0 full-speed function controller, USB transceiver, oscillator, EEPROM, and asynchronous serial data bus (UART) with full modem control signals in a compact 5x5 mm QFN-28 package (sometimes called “MLF” or “MLP”). No other external USB components are required.

The on-chip EEPROM may be used to customize the USB Vendor ID, Product ID, Product Description String, Power Descriptor, Device Release Number, and Device Serial Number as desired for OEM applications. The EEPROM is programmed on-board via the USB, allowing the programming step to be easily integrated into the product manufacturing and testing process.

Royalty-free Virtual COM Port (VCP) device drivers provided by Silicon Laboratories allow a CP2103-based product to appear as a COM port to PC applications. The CP2103 UART interface implements all RS-232/RS-485 signals, including control and handshaking signals; so, existing system firmware does not need to be modified. The device also features up to four GPIO signals that can be user-defined for status and control information. Support for I/O interface voltages down to 1.8 V is provided via a  $V_{IO}$  pin. In many existing RS-232 designs, all that is required to update the design from RS-232 to USB is to replace the RS-232 level-translator with the CP2103. Direct access driver support is available through the Silicon Laboratories USBXpress driver set. Go to [www.silabs.com](http://www.silabs.com) for the latest application notes and product support information for CP2103.

An evaluation kit for the CP2103 (Part Number: CP2103EK) is available. It includes a CP2103-based USB-to-UART/RS-232 evaluation board, a complete set of VCP device drivers, USB and RS-232 cables, and complete documentation. Contact a Silicon Labs sales representative or visit [www.silabs.com](http://www.silabs.com) to order the CP2103 Evaluation Kit.

## 2. Electrical Specifications

**Table 1. Absolute Maximum Ratings**

Parameters	Conditions	Min	Typ	Max	Units
Ambient Temperature under bias		-55	—	125	°C
Storage Temperature		-65	—	150	°C
Voltage on any I/O Pin or $\overline{\text{RST}}$ with respect to GND		-0.3	—	5.8	V
Voltage on $V_{\text{DD}}$ or $V_{\text{IO}}$ with respect to GND		-0.3	—	4.2	V
Maximum Total Current through $V_{\text{DD}}$ , $V_{\text{IO}}$ , and GND		—	—	500	mA
Maximum Output Current sunk by $\overline{\text{RST}}$ or any I/O pin		—	—	100	mA
<b>Note:</b> Stresses above those listed may cause permanent damage to the device. This is a stress rating only, and functional operation of the devices at or exceeding the conditions in the operation listings of this specification is not implied. Exposure to maximum rating conditions for extended periods may affect device reliability.					

**Table 2. Global DC Electrical Characteristics**

$V_{\text{DD}} = 3.0$  to  $3.6$  V,  $-40$  to  $+85$  °C unless otherwise specified

Parameters	Conditions	Min	Typ	Max	Units
Supply Voltage ( $V_{\text{DD}}$ )		3.0	3.3	3.6	V
Supply Voltage ( $V_{\text{IO}}$ )		1.8	3.3	$V_{\text{DD}}$	V
Supply Current <sup>1</sup>	Normal Operation, $V_{\text{REG}}$ Enabled	—	20	26	mA
Supply Current <sup>1</sup>	Suspended, $V_{\text{REG}}$ Enabled	—	80	100	μA
Supply Current - USB Pull-up <sup>2</sup>		—	200	228	μA
$V_{\text{IO}}$ Supply Current	$\text{VBUS} = 0$ $V_{\text{DD}} = 0$ $V_{\text{IO}} = 3.0$ V	—	500	—	μA
Specified Operating Temperature Range		-40	—	+85	°C
<b>Notes:</b> <ol style="list-style-type: none"> <li>If the device is connected to the USB bus, the USB Pull-up Current should be added to the supply current for total supply current.</li> <li>The USB pull-up supply current values are calculated based on USB specifications.</li> </ol>					

**Table 3. UART and Suspend I/O DC Electrical Characteristics**

$V_{IO} = V_{DD} = 2.7$  to  $3.6$  V,  $-40$  to  $+85$  °C unless otherwise specified

Parameters	Conditions	Min	Typ	Max	Units
Output High Voltage ( $V_{OH}$ )	$I_{OH} = -10 \mu A$	$V_{IO} - 0.1$	—	—	V
	$I_{OH} = -3 \text{ mA}$	$V_{IO} - 0.7$	—	—	
	$I_{OH} = -10 \text{ mA}$	—	$V_{IO} - 0.8$	—	
Output Low Voltage ( $V_{OL}$ )	$I_{OL} = 8.5 \text{ mA}$	—	—	0.6	V
	$I_{OL} = 10 \mu A$	—	—	0.1	
Input High Voltage ( $V_{IH}$ )		2.0	—	—	V
Input Low Voltage ( $V_{IL}$ )		—	—	0.8	V
Input Leakage Current	Weak pull-ups enabled	—	25	50	$\mu A$
	Weak pull-ups disabled	—	—	$\pm 1$	
Maximum Input Voltage	Open drain, logic high (1)	—	—	5.8	V

**Table 4. UART and Suspend I/O DC Electrical Characteristics (Low-Voltage Operation)**

$V_{IO} = 1.8$  V,  $V_{DD} = 2.7$  to  $3.6$  V,  $-40$  to  $+85$  °C unless otherwise specified

Parameters	Conditions	Min	Typ	Max	Units
Output High Voltage ( $V_{OH}$ )	$I_{OH} = -10 \mu A$	$V_{IO} - 0.1$	—	—	V
	$I_{OH} = -1 \text{ mA}$	$V_{IO} - 0.4$	—	—	
Output Low Voltage ( $V_{OL}$ )	$I_{OL} = 10 \mu A$	—	—	0.1	V
	$I_{OL} = 3 \text{ mA}$	—	—	0.4	
Input High Voltage ( $V_{IH}$ )		$V_{IO} \times 0.7$	—	—	V
Input Low Voltage ( $V_{IL}$ )		—	—	$V_{IO} \times 0.3$	V
Input Leakage Current	Weak pull-ups enabled	—	—	$\pm 1$	$\mu A$
	Weak pull-ups disabled	—	6	15	
Maximum Input Voltage	Open drain, logic high (1)	—	—	5.8	V

**Table 5. Reset Electrical Characteristics**

–40 to +85 °C unless otherwise specified

Parameters	Conditions	Min	Typ	Max	Units
$\overline{\text{RST}}$ Input High Voltage		0.7 x VIO	—	—	V
$\overline{\text{RST}}$ Input Low Voltage		—	—	0.3 x VIO	V
Minimum $\overline{\text{RST}}$ Low Time to Generate a System Reset		15	—	—	μs

**Table 6. Voltage Regulator Electrical Specifications**

–40 to +85 °C unless otherwise specified

Parameters	Conditions	Min	Typ	Max	Units
Input Voltage Range		4.0	—	5.25	V
Output Voltage	Output Current = 1 to 100 mA*	3.0	3.3	3.6	V
VBUS Detection Input Threshold		1.0	1.8	4.0	V
Bias Current		—	110	—	μA

\*Note: The maximum regulator supply current is 100 mA.

## 3. Pinout and Package Definitions

**Table 7. CP2103 Pin Definitions**

Name	Pin #	Type	Description
V <sub>DD</sub>	6	Power In	3.0–3.6 V Power Supply Voltage Input.
		Power Out	3.3 V Voltage Regulator Output. See "9. Voltage Regulator" on page 16.
V <sub>IO</sub>	5	Power In	1.8 V to V <sub>DD</sub> I/O Supply Voltage Input.
GND	2		Ground. Must be tied to ground.
SGND			Ground. Must be tied to ground.
$\overline{\text{RST}}$	9	D I/O	Device Reset. Open-drain output of internal POR or V <sub>DD</sub> monitor. An external source can initiate a system reset by driving this pin low for at least 15 $\mu\text{s}$ .
REGIN	7	Power In	5 V Regulator Input. This pin is the input to the on-chip voltage regulator.
VBUS	8	D In	VBUS Sense Input. This pin should be connected to the VBUS signal of a USB network. A 5 V signal on this pin indicates a USB network connection.
D+	3	D I/O	USB D+
D-	4	D I/O	USB D-
TXD	25	D Out	Asynchronous data output (UART Transmit)
RXD	24	D In	Asynchronous data input (UART Receive)
CTS	22*	D In	Clear To Send control input (active low)
RTS	23*	D Out	Ready to Send control output (active low)
DSR	26*	D in	Data Set Ready control input (active low)
DTR	27*	D Out	Data Terminal Ready control output (active low)
DCD	28*	D In	Data Carrier Detect control input (active low)
RI	1*	D In	Ring Indicator control input (active low)
SUSPEND	12*	D Out	This pin is driven high when the CP2103 enters the USB suspend state.
$\overline{\text{SUSPEND}}$	11*	D Out	This pin is driven low when the CP2103 enters the USB suspend state.
NC	10, 13–15, 20–21		These pins should be left unconnected or tied to V <sub>DD</sub> .
GPIO.3	16	D I/O	User-configurable input or output.
GPIO.2	17	D I/O	User-configurable input or output.
GPIO.1	18	D I/O	User-configurable input or output.
GPIO.0	19	D I/O	User-configurable input or output.

**\*Note:** Pins can be left unconnected when not used.



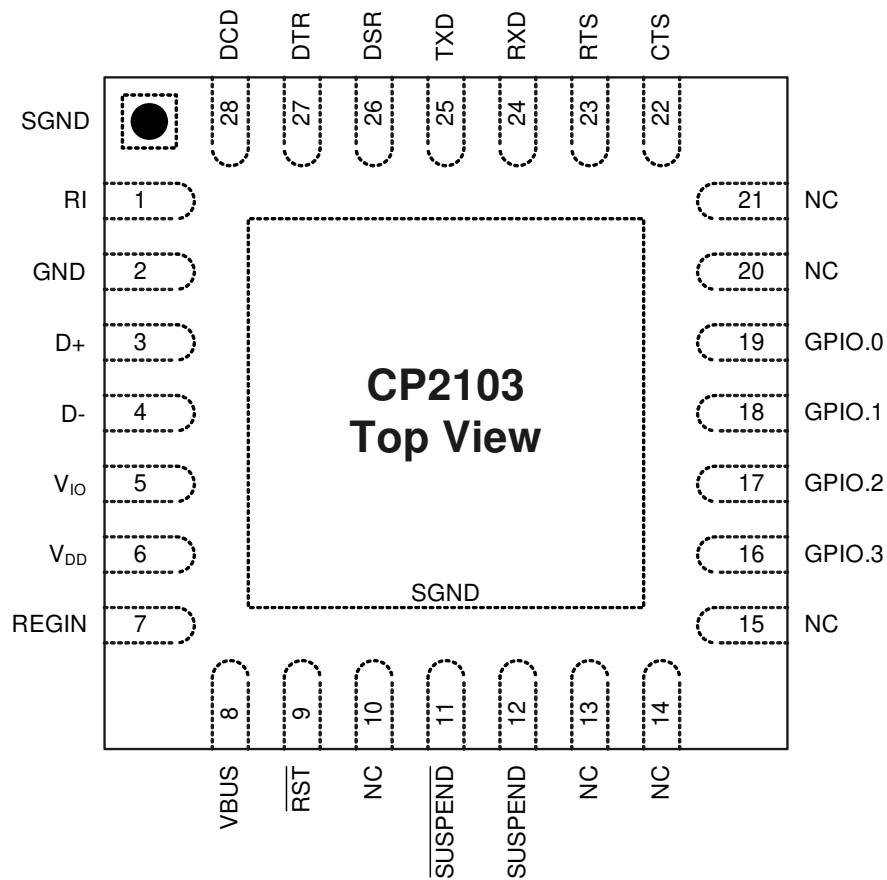
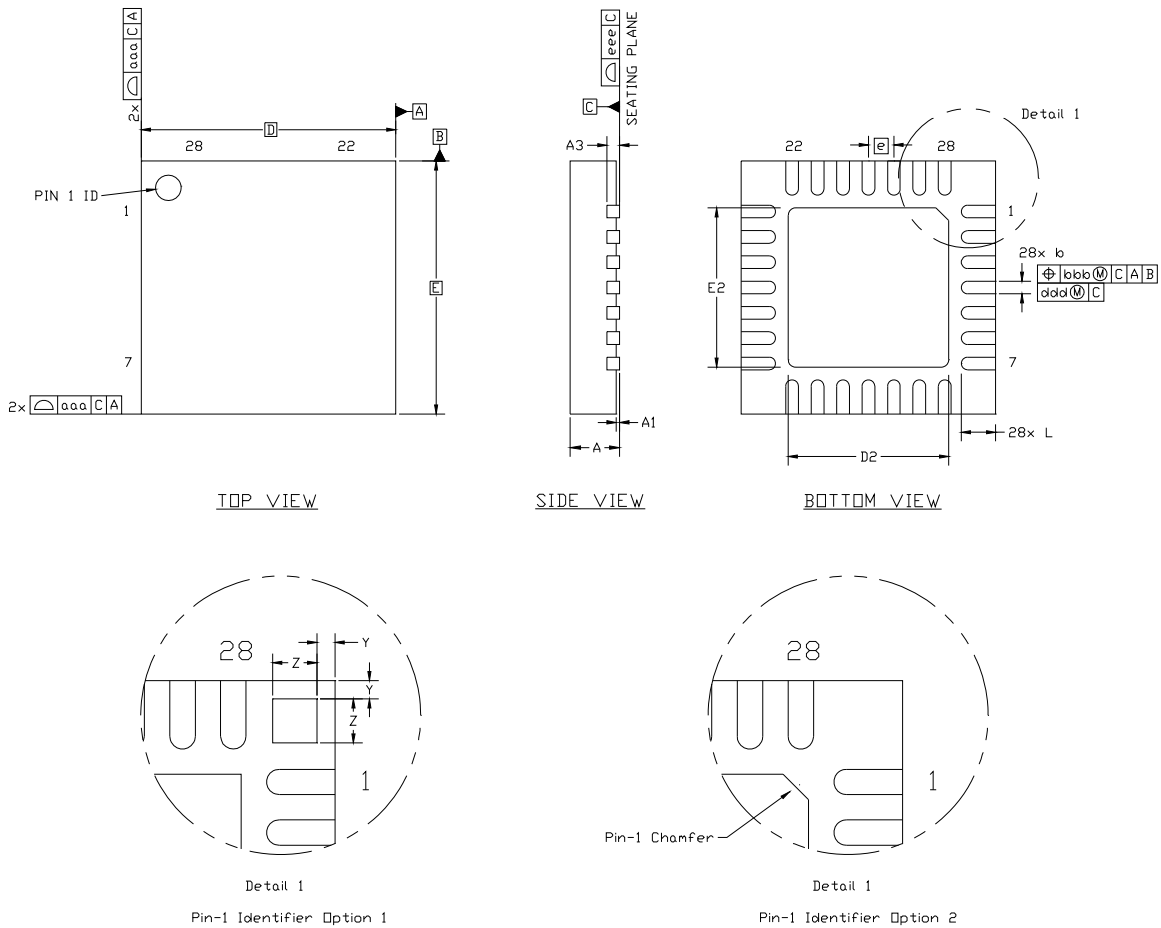

Figure 2. QFN-28 Pinout Diagram (Top View)



**Figure 3. QFN-28 Package Drawing**

**Table 8. QFN-28 Package Dimensions**

Dimension	Min	Nom	Max
A	0.80	0.90	1.00
A1	0.03	0.07	0.11
A3	0.25 REF		
b	0.18	0.25	0.30
D	5.00 BSC.		
D2	2.90	3.15	3.35
e	0.50 BSC.		
E	5.00 BSC.		
E2	2.90	3.15	3.35
L	0.45	0.55	0.65
aaa	0.15		
bbb	0.10		
ddd	0.05		
eee	0.08		
Z	0.435		
Y	0.18		

**Notes:**

1. All dimensions shown are in millimeters (mm) unless otherwise noted.
2. Dimensioning and tolerancing per ANSI Y14.5M-1994.
3. This drawing conforms to JEDEC outline MO-243, variation VHHD except for custom features D2, E2, L, Z, and Y which are toleranced per supplier designation.
4. Recommended card reflow profile is per the JEDEC/IPC J-STD-020 specification for small body components.

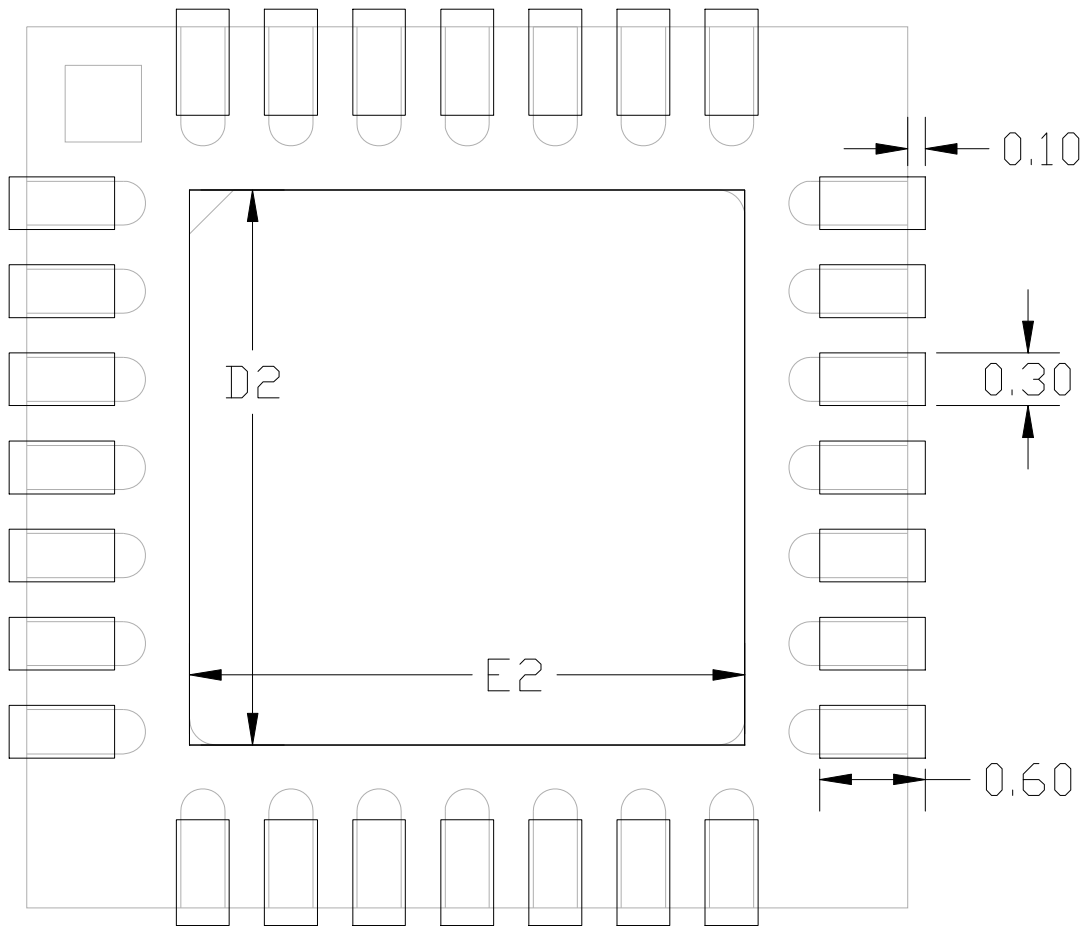

Figure 4. Typical QFN-28 Land Pattern

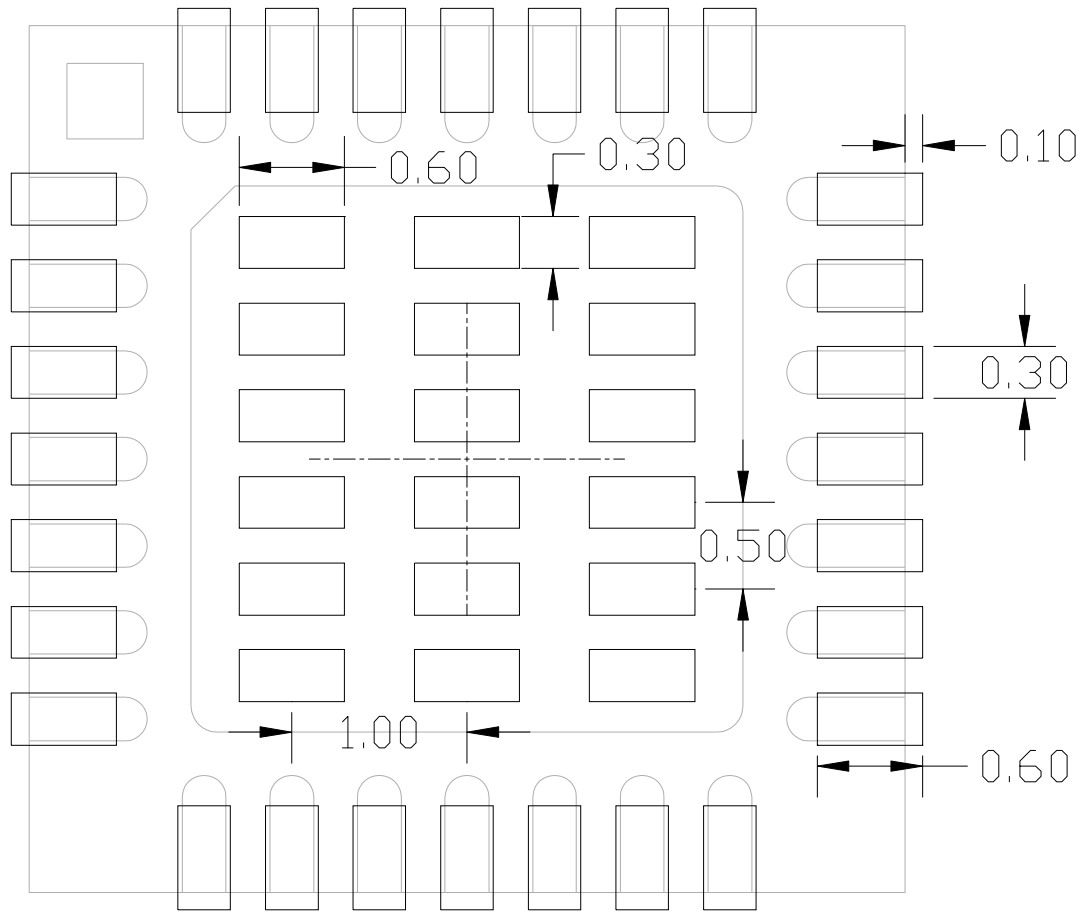

Figure 5. Typical QFN-28 Solder Paste Diagram

## 4. USB Function Controller and Transceiver

The universal serial bus function controller in the CP2103 is a USB 2.0 compliant full-speed device with integrated transceiver and on-chip matching and pull-up resistors. The USB function controller manages all data transfers between the USB and the UART as well as command requests generated by the USB host controller and commands for controlling the function of the UART.

The USB Suspend and Resume signals are supported for power management of both the CP2103 device as well as external circuitry. The CP2103 will enter Suspend mode when Suspend signaling is detected on the bus. Upon entering Suspend mode, the CP2103 asserts the  $\overline{\text{SUSPEND}}$  and  $\overline{\text{SUSPEND}}$  signals.  $\overline{\text{SUSPEND}}$  and  $\overline{\text{SUSPEND}}$  are also asserted after a CP2103 reset until device configuration during USB Enumeration is complete.

The CP2103 exits the Suspend mode when any of the following events occurs: (1) Resume signaling is detected or generated, (2) a USB Reset signal is detected, or (3) a device reset occurs. Upon exit from Suspend mode, the  $\overline{\text{SUSPEND}}$  and  $\overline{\text{SUSPEND}}$  signals are de-asserted.

Both  $\overline{\text{SUSPEND}}$  and  $\overline{\text{SUSPEND}}$  temporarily float high during a CP2103 reset. If this behavior is undesirable, a strong pulldown (10 k $\Omega$ ) can be used to ensure  $\overline{\text{SUSPEND}}$  remains low during reset. See Figure 6 for other recommended options.

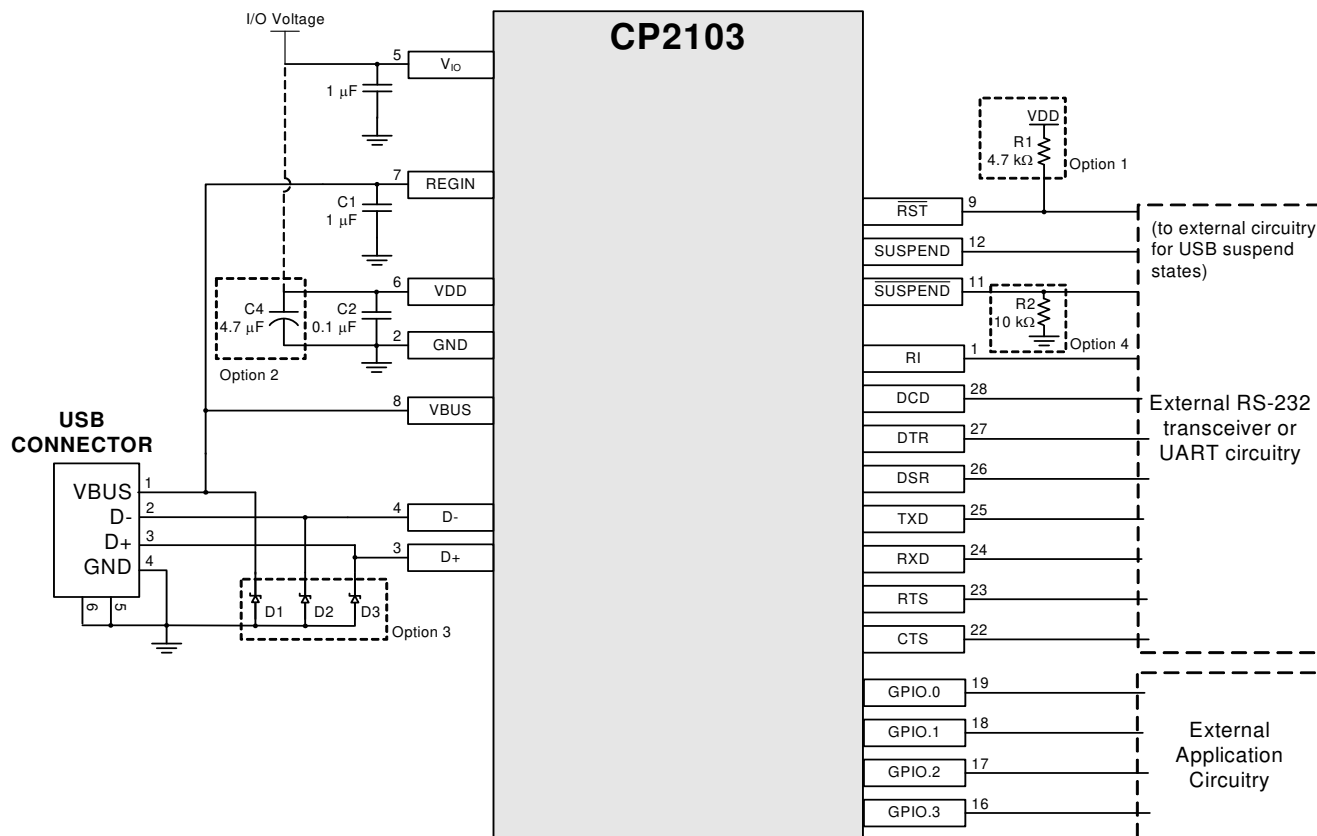

Option 1: A 4.7 k $\Omega$  pull-up resistor can be added to increase noise immunity.

Option 2: A 4.7  $\mu\text{F}$  capacitor can be added if powering other devices from the on-chip regulator.

Option 3: Avalanche transient voltage suppression diodes should be added for ESD protection.

Use Littelfuse p/n SP0503BAHT or equivalent.

Option 4: 10 k $\Omega$  resistor to ground to hold  $\overline{\text{SUSPEND}}$  low on initial power on or device reset.

**Figure 6. Typical Connection Diagram**

## 5. Asynchronous Serial Data Bus (UART) Interface

The CP2103 UART interface consists of the TX (transmit) and RX (receive) data signals as well as the RTS, CTS, DSR, DTR, DCD, and RI control signals. The UART supports RTS/CTS, DSR/DTR, and X-On/X-Off handshaking.

The UART can be programmed to support a variety of data formats and baud rates. If the Virtual COM Port drivers are used, the data format and baud rate are set during COM port configuration on the PC. If the USBXpress drivers are used, the CP2103 is configured through the USBXpress API. The available data formats and baud rates are listed in Table 9.

**Table 9. Data Formats and Baud Rates**

<b>Data Bits</b>	5, 6, 7, and 8
<b>Stop Bits</b>	1, 1.5 <sup>1</sup> , and 2
<b>Parity Type</b>	None, Even, Odd, Mark, Space
<b>Baud Rates</b> <sup>2</sup>	300, 600, 1200, 1800, 2400, 4000, 4800, 7200, 9600, 14400, 16000, 19200, 28800, 38400, 51200, 56000, 57600, 64000, 76800, 115200, 128000, 153600, 230400, 250000, 256000, 460800, 500000, 576000, 921600 <sup>3</sup>
<b>Notes:</b>	
1.	5-bit only.
2.	Additional baud rates are supported. See “AN205: CP210x Baud Rate Support”.
3.	7 or 8 data bits only.

## 6. GPIO Pins

The CP2103 supports four user-configurable GPIO pins for status and control information. More information regarding the configuration and use of these pins can be found in “AN144: CP21xx Device Customization Guide” and “AN223: Port Configuration and GPIO for CP210x” available at [www.silabs.com](http://www.silabs.com).

## 7. Internal EEPROM

The CP2103 includes an internal EEPROM that may be used to customize the USB Vendor ID (VID), Product ID (PID), Product Description String, Power Descriptor, Device Release Number, and Device Serial Number as desired for OEM applications. If the EEPROM is not programmed with OEM data, the default configuration data shown in Table 10 is used.

While customization of the USB configuration data is optional, it is recommended to customize the VID/PID combination. A unique VID/PID combination prevents the driver from conflicting with any other USB driver. A vendor ID can be obtained from [www.usb.org](http://www.usb.org), or Silicon Labs can provide a free PID for the OEM product that can be used with the Silicon Laboratories VID. It is also recommended to customize the serial number if the OEM application is one in which it is possible for multiple CP2103-based devices to be connected to the same PC.

The internal EEPROM is programmed via the USB. This allows the OEM's USB configuration data and serial number to be written to the CP2103 on-board during the manufacturing and testing process. A stand-alone utility for programming the internal EEPROM is available from Silicon Labs. A library of routines provided in the form of a Windows<sup>®</sup> DLL is also available. This library can be used to integrate the EEPROM programming step into custom software used by the OEM to streamline testing and serial number management during manufacturing. The EEPROM has a typical endurance of 100,000 write cycles with a data retention of 100 years. USB descriptors can be locked to prevent future modification.

**Table 10. Default USB Configuration Data**

Name	Value
Vendor ID	10C4h
Product ID	EA60h
Power Descriptor (Attributes)	80h
Power Descriptor (Max. Power)	32h
Release Number	0100h
Serial Number	0001 (63 characters maximum)
Product Description String	"CP2103 USB to UART Bridge Controller" (126 characters maximum)

## 8. CP2103 Device Drivers

There are two sets of device drivers available for the CP2103 devices: the Virtual COM Port (VCP) drivers and the USBXpress Direct Access drivers. Only one set of drivers is necessary to interface with the device. The latest drivers are available at <http://www.silabs.com/products/microcontroller/downloads.asp>.

### 8.1. Virtual COM Port Drivers

The CP2103 Virtual COM Port (VCP) device drivers allow a CP2103-based device to appear to the PC's application software as a COM port. Application software running on the PC accesses the CP2103-based device as it would access a standard hardware COM port. However, actual data transfer between the PC and the CP2103 device is performed over the USB interface. Therefore, existing COM port applications may be used to transfer data via the USB to the CP2103-based device without modifying the application. See "AN197: Serial Communications Guide for the CP210x" for example code for interfacing to a CP2103 using the Virtual COM drivers.

### 8.2. USBXpress Drivers

The Silicon Laboratories USBXpress drivers provide an alternate solution for interfacing with CP2103 devices. No serial port protocol expertise is required. Instead, a simple, high-level application program interface (API) is used to provide simpler CP210x connectivity and functionality. The USBXpress for CP210x Development Kit includes Windows device drivers, Windows device driver installers and uninstallers, and a host interface function library (host API) provided in the form of a Windows Dynamic Link Library (DLL). The USBXpress driver set is recommended for new products that also include new PC software. The USBXpress interface is described in "AN169: USBXpress<sup>®</sup> Programmer's Guide."

### 8.3. Driver Customization

In addition to customizing the device as described in "7. Internal EEPROM", the drivers and the drivers installation package can be also be customized. See "AN220: USB Driver Customization" for more information on generating customized VCP and USBXpress drivers.

### 8.4. Driver Certification

The default drivers that are shipped with the CP2103 are Microsoft WHQL (Windows Hardware Quality Labs) certified. The certification means that the drivers have been tested by Microsoft, and their latest operating systems (XP and Vista) allow the drivers to be installed without any warnings or errors.

The customized drivers generated using the AN220 software are not automatically certified. They must go first through the Microsoft Driver Reseller Submission process. Contact Silicon Laboratories support for assistance with this process.

## 9. Voltage Regulator

The CP2103 includes an on-chip 5 to 3 V voltage regulator. This allows the CP2103 to be configured as either a USB bus-powered device or a USB self-powered device. These configurations are shown in Figures 7 and 8. When enabled, the 3 V voltage regulator output appears on the  $V_{DD}$  pin and can be used to power external 3 V devices. See Table 11 for the voltage regulator electrical characteristics.

Alternatively, if 3 V power is supplied to the  $V_{DD}$  pin, the CP2103 can function as a USB self-powered device with the voltage regulator disabled. For this configuration, it is recommended that the REGIN input be tied to the 3 V net to disable the voltage regulator. This configuration is shown in Figure 9.

The USB max power and power attributes descriptor must match the device power usage and configuration. See “AN144: CP21xx Device Customization Guide” for information on how to customize USB descriptors for the CP2103.

**Note:** It is recommended that additional decoupling capacitance (e.g., 0.1  $\mu\text{F}$  in parallel with 1.0  $\mu\text{F}$ ) be provided on the REGIN input.

**Table 11. Voltage Regulator Electrical Specifications**

–40 to +85 °C unless otherwise specified.

Parameter	Conditions	Min	Typ	Max	Units
Input Voltage Range		4.0	—	5.25	V
Output Voltage	Output Current = 1 to 100 mA*	3.0	3.3	3.6	V
VBUS Detection Input Threshold		1.0	1.8	4.0	V
Bias Current		—	110	—	$\mu\text{A}$

\***Note:** The maximum regulator supply current is 100 mA.

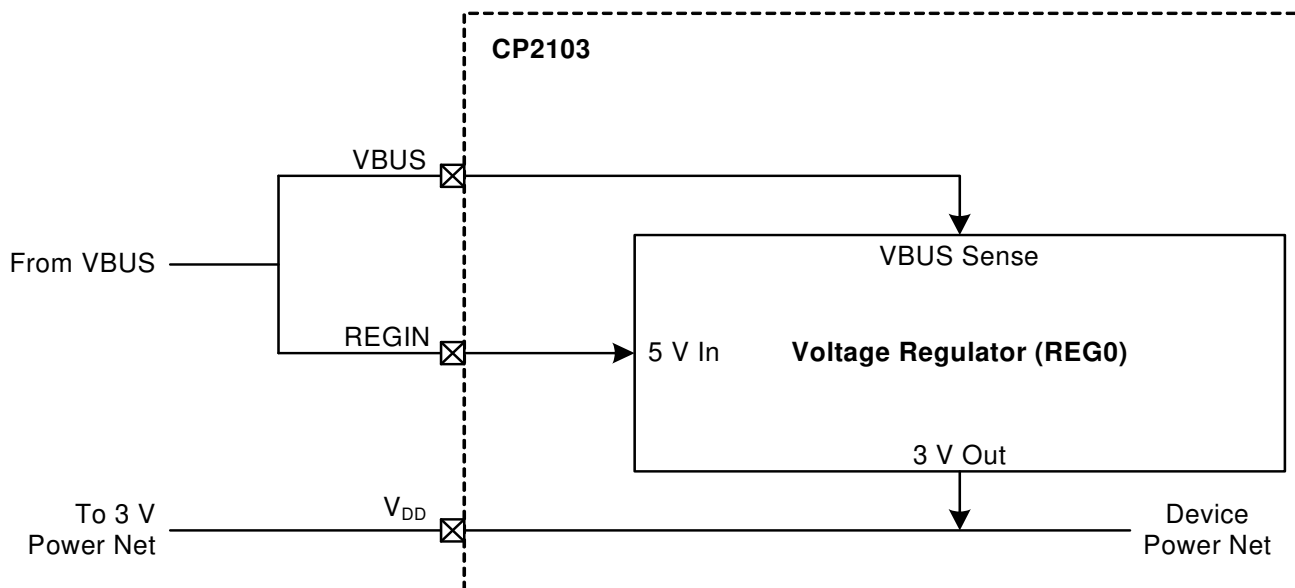

**Figure 7. Configuration 1: USB Bus-Powered**



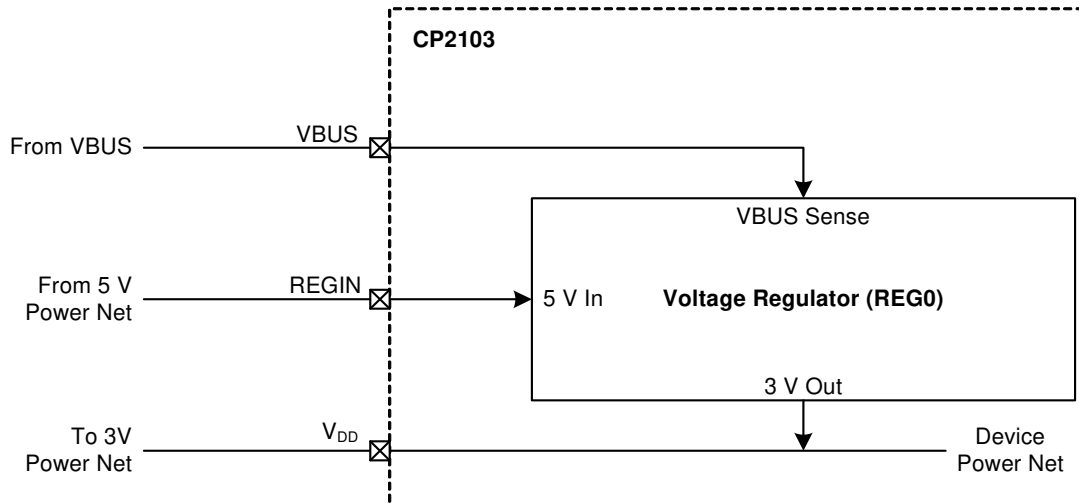

Figure 8. Configuration 2: USB Self-Powered

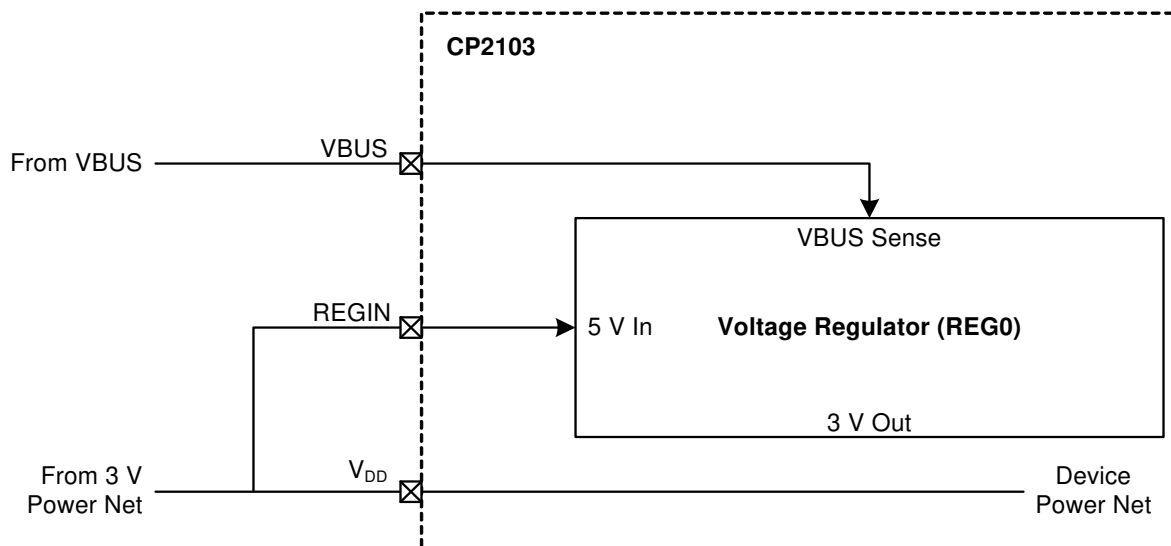

Figure 9. Configuration 3: USB Self-Powered, Regulator Bypassed

## 10. Relevant Application Notes

The following application notes are applicable to the CP2103. The latest versions of these application notes and their accompanying software are available at:

<http://www.silabs.com/products/mcu/Pages/ApplicationNotes.aspx>.

- **AN144: CP21xx Device Customization Guide**

This application note describes how to use the AN144 software to configure the USB parameters on the CP2103 devices.

- **AN169: USBXpress® Programmer's Guide**

This application note describes the USBXpress API interface and includes example code.

- **AN197: Serial Communications Guide for the CP210x**

This application note describes how to use the standard Windows COM port function to communicate with the CP2103 and includes example code.

- **AN205: CP210x Baud Rate Support**

This application note describes how to use the AN205 software to configure the baud rate aliasing feature on the CP2103 devices.

- **AN220: USB Driver Customization**

This application note describes how to use the AN220 software to customize the VCP or USBXpress drivers with OEM information.

- **AN223: Port Configuration And GPIO for CP210x**

This application note describes how to use the AN223 software to configure the GPIO's other configurable pins.

## **DOCUMENT CHANGE LIST**

### **Revision 0.1 to Revision 0.2**

- Updated “Linux 2.40” bullet on page 1.

### **Revision 0.2 to Revision 0.3**

- Added additional supported operating systems on page 1.
- Changed VDD conditions of Tables 2 and 3 from a minimum of 2.7 to 3.0 V.
- Updated typical and max Supply current numbers in Table 2.
- Updated package drawings in Figures 3, 4, and 5.
- Removed tantalum requirement in Figure 6.
- Consolidate Sections 9 and 10.
- Added Section "10. Relevant Application Notes" on page 18.

### **Revision 0.3 to Revision 0.4**

- Added voltage numbers to Table 4 on page 6.
- Corrected notes numbering in Table 8 on page 10.

### **Revision 0.4 to Revision 1.0**

- Updated supported operating systems on page 1.
- Updated notes in Table 2.
- Updated AN144 title throughout document.

Silicon Labs

# Simplicity Studio™4



## Simplicity Studio

One-click access to MCU and wireless tools, documentation, software, source code libraries & more. Available for Windows, Mac and Linux!



**IoT Portfolio**  
[www.silabs.com/loT](http://www.silabs.com/loT)



**SW/HW**  
[www.silabs.com/simplicity](http://www.silabs.com/simplicity)



**Quality**  
[www.silabs.com/quality](http://www.silabs.com/quality)



**Support and Community**  
[community.silabs.com](http://community.silabs.com)

### Disclaimer

Silicon Labs intends to provide customers with the latest, accurate, and in-depth documentation of all peripherals and modules available for system and software implementers using or intending to use the Silicon Labs products. Characterization data, available modules and peripherals, memory sizes and memory addresses refer to each specific device, and "Typical" parameters provided can and do vary in different applications. Application examples described herein are for illustrative purposes only. Silicon Labs reserves the right to make changes without further notice and limitation to product information, specifications, and descriptions herein, and does not give warranties as to the accuracy or completeness of the included information. Silicon Labs shall have no liability for the consequences of use of the information supplied herein. This document does not imply or express copyright licenses granted hereunder to design or fabricate any integrated circuits. The products are not designed or authorized to be used within any Life Support System without the specific written consent of Silicon Labs. A "Life Support System" is any product or system intended to support or sustain life and/or health, which, if it fails, can be reasonably expected to result in significant personal injury or death. Silicon Labs products are not designed or authorized for military applications. Silicon Labs products shall under no circumstances be used in weapons of mass destruction including (but not limited to) nuclear, biological or chemical weapons, or missiles capable of delivering such weapons.

### Trademark Information

Silicon Laboratories Inc.®, Silicon Laboratories®, Silicon Labs®, SiLabs® and the Silicon Labs logo®, Bluegiga®, Bluegiga Logo®, Clockbuilder®, CMEMS®, DSPPLL®, EFM®, EFM32®, EFR®, Ember®, Energy Micro, Energy Micro logo and combinations thereof, "the world's most energy friendly microcontrollers", Ember®, EZLink®, EZRadio®, EZRadioPRO®, Gecko®, ISOModem®, Precision32®, ProSLIC®, Simplicity Studio®, SiPHY®, Telegesis, the Telegesis Logo®, USBXpress® and others are trademarks or registered trademarks of Silicon Labs. ARM, CORTEX, Cortex-M3 and THUMB are trademarks or registered trademarks of ARM Holdings. Keil is a registered trademark of ARM Limited. All other products or brand names mentioned herein are trademarks of their respective holders.



**SILICON LABS**

Silicon Laboratories Inc.  
400 West Cesar Chavez  
Austin, TX 78701  
USA

<http://www.silabs.com>