

# MLX92362/MLX92361

Isolated output programmable Hall Effect Latch/Switch/Omnipolar switch  
Datasheet

## 1. Features and Benefits

- Normal or lateral magnetic sensitivity options X,Y,Z
- Switch output – fully isolated from the supply voltage, OUTA/OUTB potentials can be below GND or above VDD
- Typical  $R_{ON}$  of  $3\Omega$
- Output current up to 100mA (AMR 200mA)
- Programmable magnetic thresholds and threshold temperature coefficient
- Programmable magnetic Latch, Unipolar and Omnipolar Switch function
- Built-in daisy chain functionality to synchronize multiple devices
- Operating voltage range from 4.5V to 28V
- Low average supply current –  $180\mu A$  typical
- Under-Voltage Reset protection
- Thermal protection
- Package RoHS compliant TSOT-6L

## 2. Application Examples

- Reed switch replacement
- Fluid level meter applications
- Push button
- Direct load driving
- HIGH/LOW side switch

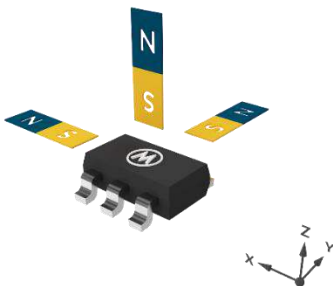

## 3. Description

The MLX92362/61 is a monolithic sensor IC sensitive to normal or lateral magnetic field.

The MLX92362/61 has two output pins, OUTA and OUTB. They are connected to an integrated, electrically isolated switch. The MLX92362 can be programmed to output direct or inverted signal from one of the two sensitive axes – X(Y) or Z. The signal available on the output pins is result of comparison between the applied magnetic field and the pre-programmed magnetic thresholds  $B_{OP}$  and  $B_{RP}$  for the selected sensitive axis.

The MLX92362/61 can be programmed to act as magnetic latch, unipolar switch or omnipolar switch.

The MLX92362/61 can be used as general replacement of reed switches having the advantage of solid-state reliability. Note that a series of ICs can be connected in a single module, and synchronized via the same 3-wire interface thanks to the built-in daisy chain function.

Customers can benefit from the end-of-line (EoL) programming capability of the MLX92362 or alternatively, they can choose a pre-programmed MLX92361 device.

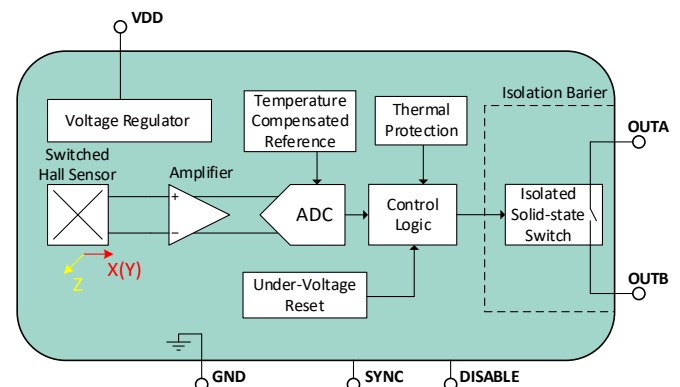

MLX92362 functional diagram

# MLX92362/MLX92361

Isolated output programmable Hall Effect Latch/Switch/Omnipolar switch  
Datasheet

## Contents

1. Features and Benefits.....	1
2. Application Examples.....	1
3. Description .....	1
4. Ordering Information .....	3
5. Glossary of Terms.....	4
6. Absolute Maximum Ratings .....	4
7. General Electrical and Timing Specifications.....	5
8. Version specific parameters .....	7
8.1. MLX92362LSE-ABA-000-RE .....	7
8.2. MLX92361LSE-ABC-001-RE .....	7
9. Detailed Description .....	8
9.1. Active magnetic pole definition .....	8
9.2. Average supply current .....	8
9.3. DISABLE pin function .....	8
9.4. SYNC pin function .....	9
9.5. Daisy chain operating mode.....	9
10. Magnetic Behavior.....	11
10.1. Latch Sensor .....	11
10.2. Unipolar Switch Sensor.....	11
10.3. Omnipolar Switch Sensor .....	12
11. Open drain application schematics – Low side and High side .....	13
12. Fluid level meter application schematic.....	14
13. Package Information.....	15
13.1. TSOT-6L (SE Package) .....	15
14. Standard Information .....	17
15. ESD Precautions.....	17
16. Contact.....	17
17. Disclaimer.....	18

# MLX92362/MLX92361

Isolated output programmable Hall Effect Latch/Switch/Omnipolar switch  
Datasheet

## 4. Ordering Information

Product	Temperature	Package	Option Code	Packing Form	Definition
MLX92362	L	SE	AAA-000	RE	Customer programmable Y/Z-axis sensitive device
MLX92362	L	SE	ABA-000	RE	Customer programmable X/Z-axis sensitive device
MLX92361	L	SE	ABC-001	RE	Pre-programmed X-axis sensitive device

### Legend:

Temperature Code:	L: T <sub>A</sub> from -40°C to 150°C
Package Code:	“SE” for TSOT-6L
Option Code:	<u>AAA</u> = Y/Z-axis Programmable sensor <u>ABA</u> = X/Z-axis Programmable sensor <u>AAB</u> = Pre-programmed sensor, Z-axis sensitive <u>AAC</u> = Pre-programmed sensor, Y-axis sensitive <u>ABB</u> = Pre-programmed sensor, Z-axis sensitive <u>ABC</u> = Pre-programmed sensor, X-axis sensitive
Packing Form:	RE: tape on reel
Ordering Example:	MLX92362LSE-ABA-000-RE

# MLX92362/MLX92361

Isolated output programmable Hall Effect Latch/Switch/Omnipolar switch  
Datasheet

## 5. Glossary of Terms

Gauss (G), Tesla (T)	Units for the magnetic flux density – 1 mT = 10 G
TC	Temperature Coefficient of the magnetic threshold (in ppm/°C)
ADC	Analog-to-Digital Converter
B <sub>OP</sub>	Operating magnetic threshold
B <sub>RP</sub>	Release magnetic threshold

## 6. Absolute Maximum Ratings

Parameter	Symbol	Value	Unit
Supply voltage <sup>(1)</sup>	V <sub>DD</sub>	32	V
Supply current <sup>(1,2, 3)</sup>	I <sub>DD</sub>	20	mA
Reverse supply voltage <sup>(1)</sup>	V <sub>DDREV</sub>	-0.5	V
Reverse supply current <sup>(1, 3, 4)</sup>	I <sub>DDREV</sub>	-20	mA
Maximum voltage difference between any combination of VDD, GND, OUTA and OUTB pins <sup>(1)</sup>	V <sub>DIFF</sub>	±32	V
Output pin current <sup>(1, 3, 4)</sup>	I <sub>OUTA</sub> , I <sub>OUTB</sub>	±20	mA
Output current <sup>(1, 3, 5)</sup>	I <sub>OUT</sub>	±200	mA
DISABLE pin voltage <sup>(1)</sup>	V <sub>DIS</sub>	6	V
DISABLE pin reverse voltage <sup>(1)</sup>	V <sub>DISREV</sub>	-0.5	V
DISABLE pin current <sup>(1, 3, 4)</sup>	I <sub>DIS</sub>	±20	mA
SYNC pin current <sup>(1, 3, 4)</sup>	I <sub>SYNC</sub>	±20	mA
Maximum junction temperature <sup>(6)</sup>	T <sub>J</sub>	+175	°C
ESD – HBM <sup>(7)</sup>	-	4	kV
ESD – CDM <sup>(8)</sup>	-	1000	V

Exceeding the absolute maximum ratings may cause permanent damage. Exposure to absolute maximum-rated conditions for extended periods may affect device reliability.

<sup>1</sup> For maximum 1 hour

<sup>2</sup> Including the current through the protection device

<sup>3</sup> The maximum junction temperature should not be exceeded

<sup>4</sup> Current through the protection device

<sup>5</sup> Current through the output switch

<sup>6</sup> Guaranteed by 1000 hours HTOL

<sup>7</sup> Human Body Model according AEC-Q100-002 or ANSI/ESDA/JEDEC JS-001 standard

<sup>8</sup> Charged Device Model according AEC-Q100-011 or ANSI/ESDA/JEDEC JS-002 standard

# MLX92362/MLX92361

Isolated output programmable Hall Effect Latch/Switch/Omnipolar switch  
Datasheet

## 7. General Electrical and Timing Specifications

Operating conditions  $V_{DD} = 4.5V$  to  $28V$ ,  $T_A = -40^{\circ}C$  to  $150^{\circ}C$  (unless otherwise specified)

Parameter	Symbol	Condition	Min	Typ <sup>(1)</sup>	Max	Unit
Under Voltage Reset threshold	$V_{UVR}$		–	–	4.2	V
Under Voltage Reset reaction time <sup>(2)</sup>	$t_{UVR}$	$V_{DD}$ drop to 2V	–	0.4	–	$\mu s$
Output leakage	$I_{OFF}$	$V_{OUTA} = 0V, V_{OUTB} = 28V$ or $V_{OUTA} = 28V, V_{OUTB} = 0V$	–	–	1	$\mu A$
Output turned-on resistance <sup>(3)</sup>	$R_{ON}$	$I_{OUT} = 50mA$ $T_A = -40..105^{\circ}C$	–	3	5	$\Omega$
Output turned-on resistance	$R_{ON}$	$I_{OUT} = 50mA$ $T_A = -40..150^{\circ}C$	–	3	6	$\Omega$
Output turned-off resistance <sup>(2)</sup>	$R_{OFF}$	$V_{OUTA} = 5V, V_{OUTB} = 0V$ or $V_{OUTA} = 0V, V_{OUTB} = 5V$	–	>10	–	$M\Omega$
Output isolation resistance to GND <sup>(2)</sup>	$R_{ISO}$	$V_{OUTA} = V_{OUTB} = 5V$	–	>10	–	$M\Omega$
OUTA parasitic capacitance to GND <sup>(2)</sup>	$C_{OUTA\_GND}$	$V_{AC} = 1V, f = 50kHz$ Switch state = OFF, OUTB unconnected;	–	9	–	pF
OUTB parasitic capacitance to GND <sup>(2)</sup>	$C_{OUTB\_GND}$	$V_{AC} = 1V, f = 50kHz$ Switch state = OFF, OUTA unconnected;	–	9	–	pF
OUTA parasitic capacitance to OUTB <sup>(2)</sup>	$C_{OUTA\_OUTB}$	$V_{AC} = 1V, f = 50kHz$ Switch state = OFF;	–	4	–	pF
Output voltage operating range	$V_{OUTA},$ $V_{OUTB}$		$V_{DD} - 28$	–	28	V
Output voltage difference, $V_{OUTA} - V_{OUTB}$			-28	–	28	V
Output rise time <sup>(2,4)</sup>	$t_R$	$R_{PU}=10k\Omega, V_{DD}=12V,$ $V_{PU}=5V, C_{LOAD}=50pF$	3	8	20	$\mu s$
Output fall time <sup>(2,4)</sup>	$t_F$	$R_{PU}=10k\Omega, V_{DD}=12V,$ $V_{PU}=5V, C_{LOAD}=50pF$	3	8	20	$\mu s$
Power-On time <sup>(5,6)</sup>	$t_{ON}$	$V_{DD}=12V$ $\Delta V_{DD}/\Delta t \geq 2V/\mu s$ DISABLE = 0	–	170	250	$\mu s$
Power-On state	–	Output state during $t_{ON}$	OFF			–

<sup>1</sup> Unless otherwise specified the typical values are defined at  $T_A = +25^{\circ}C$  and  $V_{DD} = 12V$ .

<sup>2</sup> Guaranteed by design and verified by characterization, not production tested.

<sup>3</sup> Guaranteed by correlation with production test at  $T_A=150^{\circ}C$  and verified by characterization.

<sup>4</sup> Open drain application, one of the outputs connected to ground, the other connected to the pull-up resistor.  $R_{PU}$  and  $V_{PU}$  are respectively the external pull-up resistor and pull-up power supply.

<sup>5</sup> The Power-On Time represents the time from reaching  $V_{DD} = 4.5V$  to the first refresh of output state.

<sup>6</sup> Power-On Slew Rate is not critical for the proper device start-up.

# MLX92362/MLX92361

Isolated output programmable Hall Effect Latch/Switch/Omnipolar switch  
 Datasheet

Parameter	Symbol	Condition	Min	Typ <sup>(1)</sup>	Max	Unit
Average supply current	I <sub>DDAVG</sub>	t <sub>SLEEP</sub> = 50ms, DISABLE = 0 T <sub>A</sub> = -40..150°C	162	180	212	μA
Average supply current <sup>(2)</sup>	I <sub>DDAVG</sub>	t <sub>SLEEP</sub> = 50ms, DISABLE = 0 T <sub>A</sub> = -40..85°C	162	180	192	μA
Peak supply current, for peaks longer than 5μs	I <sub>DDPEAK</sub>		–	1.5	2.2	mA
Output update period	T <sub>OU</sub>	DISABLE = 0	t <sub>PACT</sub> + t <sub>ACT</sub> + t <sub>SLEEP</sub>			–
Pre-Active phase duration	t <sub>PACT</sub>		96.9	102	107.1	μs
Active phase duration	t <sub>ACT</sub>		49.4	52	54.6	μs
Programmable sleep phase duration	t <sub>SLEEP</sub>	Typical range, DISABLE = 0	0.064	–	81.96	ms
Average Pre-Active phase supply current	I <sub>DDPACT</sub>	T <sub>A</sub> = -40..150°C	330	380	430	μA
Average Pre-Active phase supply current <sup>(2)</sup>	I <sub>DDPACT</sub>	T <sub>A</sub> = -40..85°C	330	380	410	μA
Average Active phase supply current	I <sub>DDACT</sub>		1.3	1.4	1.5	mA
Sleep phase supply current	I <sub>DDSLEEP</sub>	T <sub>A</sub> = -40..150°C	160	180	210	μA
Sleep phase supply current <sup>(2)</sup>	I <sub>DDSLEEP</sub>	T <sub>A</sub> = -40..85°C	160	180	190	μA
DISABLE pin input low voltage	V <sub>DIS_IL</sub>		1	1.2	1.4	V
DISABLE pin input high voltage	V <sub>DIS_IH</sub>		1.5	1.8	2	V
DISABLE pin weak pull-down current	I <sub>DIS_WPD</sub>		3	4	5.5	μA
DISABLE pin strong pull-down current	I <sub>DIS_SPD</sub>		85	100	115	μA
Propagation delay – DISABLE falling edge to Output update <sup>(3)</sup>	t <sub>DIS_PD</sub>		–	180	240	μs
DISABLE low state duration for successful Output update <sup>(3)</sup>	t <sub>DIS_LD</sub>		20	–	–	μs
SYNC pin output low voltage	V <sub>SYNC_OL</sub>	I <sub>LOAD</sub> = 1mA	20	35	60	mV
SYNC pin output high voltage	V <sub>SYNC_OH</sub>	I <sub>LOAD</sub> = 0.5mA	3.2	3.5	3.9	V
		I <sub>LOAD</sub> = 0mA	3.5	3.8	4.3	V
SYNC low state pulse duration	t <sub>SYNC_LD</sub>		45	48	51	μs
Thermal Protection	T <sub>PROT</sub>		–	190	–	°C
SE package thermal resistance	R <sub>THJA</sub>	Single layer PCB, JEDEC standard test boards, still air (LFPM=0)	–	250	–	°C/W

<sup>1</sup> Unless otherwise specified the typical values are defined at T<sub>A</sub> = +25°C and V<sub>DD</sub> = 12V

<sup>2</sup> Guaranteed by correlation with production test at T<sub>A</sub>=150°C and verified by characterization

<sup>3</sup> Guaranteed by design and verified by characterization, not production tested

# MLX92362/MLX92361

Isolated output programmable Hall Effect Latch/Switch/Omnipolar switch  
 Datasheet

## 8. Version specific parameters

### 8.1. MLX92362LSE-ABA-000-RE

Operating conditions  $V_{DD} = 4.5V$  to  $28V$ ,  $T_A = -40^{\circ}C$  to  $150^{\circ}C$  (unless otherwise specified)

Test Condition	Operating Point $B_{OP}$ (mT)			Release Point $B_{RP}$ (mT)			TC (ppm/ $^{\circ}C$ ) Typ <sup>(1)</sup>	Output polarity active pole	Sleep duration (ms)
	Min	Typ <sup>(1)</sup>	Max	Min	Typ <sup>(1)</sup>	Max			
$T_A = -40^{\circ}C$	1.4	3.0	4.6	0.5	2.0	3.6	0 <sup>(2)</sup>	X-axis Unipolar Direct switch	50
$T_A = 25^{\circ}C$	1.9	3.0	4.2	0.9	2.0	3.1			
$T_A = 150^{\circ}C$	1.5	3.0	4.6	0.5	2.0	3.5			

### 8.2. MLX92361LSE-ABC-001-RE

Operating conditions  $V_{DD} = 4.5V$  to  $28V$ ,  $T_A = -40^{\circ}C$  to  $150^{\circ}C$  (unless otherwise specified)

Test Condition		Operating Point $B_{OP}$ (mT)			Release Point $B_{RP}$ (mT)			TC (ppm/ $^{\circ}C$ ) Typ <sup>(1)</sup>	Output polarity active pole	Sleep duration (ms)
		Min	Typ <sup>(1)</sup>	Max	Min	Typ <sup>(1)</sup>	Max			
$T_A = -40^{\circ}C$	B <sub>XP_SOUTH</sub>	1.7	3.4	5.0	0.6	2.3	3.9	-2000 <sup>(2)</sup>	X-axis Omnipolar Direct switch	81.96
$T_A = 25^{\circ}C$		1.9	3.0	4.1	0.9	2.0	3.1			
$T_A = 150^{\circ}C$		0.8	2.3	3.7	0.1	1.5	2.9			
$T_A = -40^{\circ}C$	B <sub>XP_NORTH</sub>	-5.0	-3.4	-1.7	-3.9	-2.3	-0.6			
$T_A = 25^{\circ}C$		-4.1	-3.0	-1.9	-3.1	-2.0	-0.9			
$T_A = 150^{\circ}C$		-3.7	-2.3	-0.8	-2.9	-1.5	-0.1			

<sup>1</sup> Unless otherwise specified the typical values are defined at  $T_A = +25^{\circ}C$  and  $V_{DD} = 12V$

<sup>2</sup> The Temperature Coefficient is calculated using following formula:

$$TC = \frac{B_{XPTA2} - B_{XPTA1}}{B_{XPTA1} \times (T_{A2} - T_{A1})} \times 10^6, ppm/^{\circ}C$$

where:

$T_{A1} = 25^{\circ}C$ ,  $T_{A2} = 150^{\circ}C$

In case of magnetic Latch application:  $B_{XPTA1}$  ( $B_{XPTA2}$ ) =  $B_{OP}$  -  $B_{RP}$  at  $T_{A1}$  ( $T_{A2}$ )

In case of magnetic Unipolar Switch application:  $B_{XPTA1}$  ( $B_{XPTA2}$ ) =  $B_{OP}$  OR  $B_{RP}$  at  $T_{A1}$  ( $T_{A2}$ )

In case of magnetic Omnipolar Switch application:  $B_{XPTA1}$  ( $B_{XPTA2}$ ) =  $B_{OP\_SOUTH}$  -  $B_{OP\_NORTH}$  at  $T_{A1}$  ( $T_{A2}$ )

# MLX92362/MLX92361

Isolated output programmable Hall Effect Latch/Switch/Omnipolar switch  
Datasheet

## 9. Detailed Description

### 9.1. Active magnetic pole definition

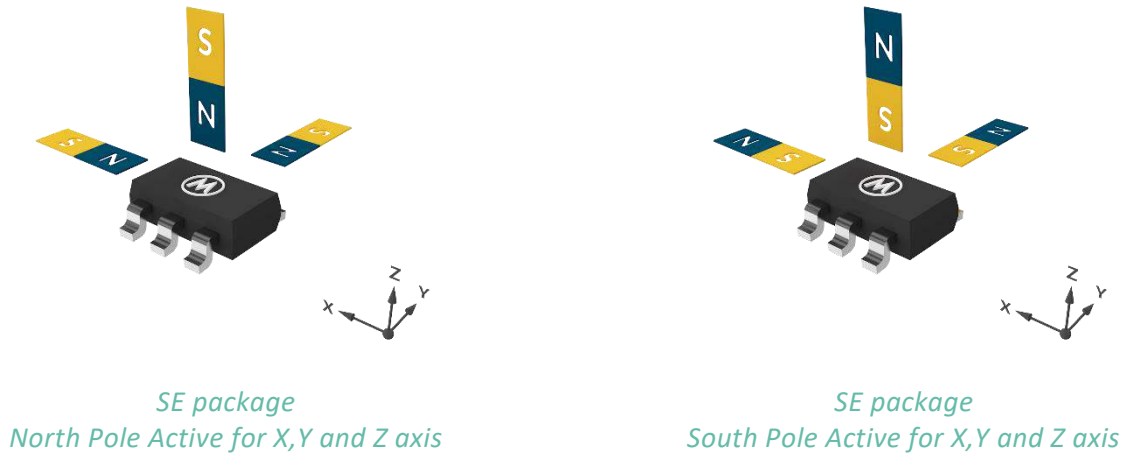

### 9.2. Average supply current

MLX92362/61 operates in a Sleep-Active mode as long as the DISABLE pin is in low state. The chip is sequencing Sleep, Pre-Active and Active phases. In Sleep phase the chip is maintaining its output state and in Pre-Active phase it is preparing for Active phase. In Active phase the chip is detecting the magnetic field and updates its output state. Taking into account all of the defined operating phases with their corresponding currents and duration the average supply current of the chip can be calculated using the following formula:

$$I_{DDAVG} = \frac{I_{DDSLLEEP} \times t_{SLEEP} + I_{DDPACT} \times t_{PACT} + I_{DDACT} \times t_{ACT}}{t_{SLEEP} + t_{PACT} + t_{ACT}}$$

Where  $I_{DDSLLEEP}$  is the supply current of the chip in sleep phase,  $t_{SLEEP}$  is the programmed sleep duration,  $I_{DDPACT}$  is the average supply current in pre-active phase,  $t_{PACT}$  is the duration of the pre-active phase,  $I_{DDACT}$  is the average supply current in active phase and  $t_{ACT}$  is the active phase duration.

When calculating the minimum and maximum average supply current only the minimum and maximum values of the  $I_{DDSLLEEP}$ ,  $I_{DDPACT}$  and  $I_{DDACT}$  should be used. The timing parameters should be always calculated as typical values since the timing parameters are derivate of the same clock source, making the ratio between them fixed. Therefore, the tolerance of the timing parameters is not affecting the average current consumption.

### 9.3. DISABLE pin function

The DISABLE pin is a 5V tolerant digital input with integrated pull-down current. The pin can be controlled by 3.3V or 5V logic outputs. The function of the pin is to disable the Active phase, preventing the output update. The pin is intended for on-demand output update. On the falling edge of the disable signal the chip wakes up, transitions to Pre-Active, then to Active phase and updates its output state. The time between the falling edge of the disable signal and the output update is  $t_{DIS\_PD}$ .

If the pin is held in high state, the chip will transition periodically to Pre-Active phase with duration  $t_{PACT}$  and then back to sleep with duration:

$$t_{SLEEP\_DIS} = 2 \times t_{SLEEP} - 108\mu s$$



This sequence of  $t_{SLEEP\_DIS}$  and  $t_{PACT}$  is repeated as long as DISABLE pin is held high. In this mode the average current consumption can be calculated with the following formula:

$$I_{DDAVG} = \frac{I_{DDSLP} \times t_{SLEEP\_DIS} + I_{DDPACT} \times t_{PACT}}{t_{SLEEP\_DIS} + t_{PACT}}$$

If the DISABLE pin is held in low state the chip operates as described in “9.2 Average supply current”.

The DISABLE pin has integrated pull-down current and it can be left unconnected if it is not used. The pull-down current has two values – strong ( $I_{DIS\_SPD}$ ) and weak ( $I_{DIS\_WPD}$ ). The strong pull-down current is always active while the DISABLE pin is in low state. The chip is switching to the weak pull-down current if the state of the pin is held in high state for more than  $\approx 65\mu s$ . The chip is switching between the weak and the strong current each  $t_{SLEEP\_DIS} + t_{PACT}$ , if the pin is held in high state.

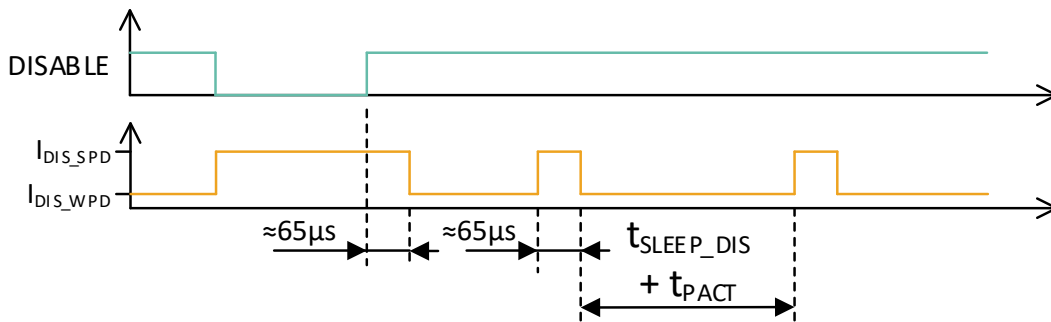

If the pin is not used, it can be left unconnected or it can be connected to GND.

## 9.4. SYNC pin function

The SYNC pin outputs an active low pulse at the end of each Active phase, indicating the output state is updated. The state of the output is valid  $20\mu s$  after the rising edge of the SYNC pin. If the pin is not used, it should be left unconnected.

## 9.5. Daisy chain operating mode

The daisy chain operating mode makes use of the SYNC and DISABLE pins for applications with more than one MLX92362/61 device. Such application is “12 Fluid level meter application schematic” where only three devices are used for simplicity, but practically tens or hundreds of devices can be used. The first chip in the chain (the one with DISABLE pin unconnected or connected to GND) is called master. Each of the subsequent devices is a slave. The master is initiating the update of the full chain, making the update behavior predictable and repeatable. First, the master is updating its output, then the slave next to the master and so on.

The figure below illustrates the function, in a simplified way with Pre-Active phase omitted.

# MLX92362/MLX92361

Isolated output programmable Hall Effect Latch/Switch/Omnipolar switch  
Datasheet

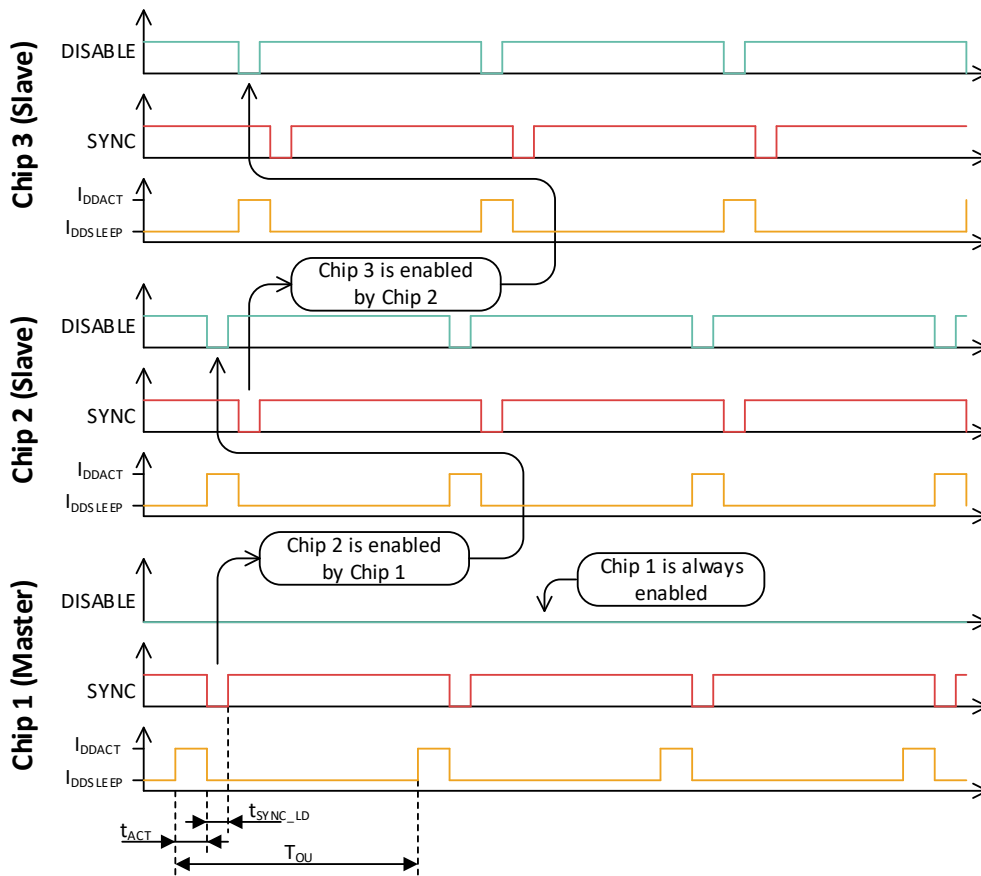

Other benefit of the daisy chain operating mode is reduced peak current consumption. The chip to chip synchronization ensures only one device will be in Active phase at a time as long as the total sum of Pre-Active and Active phases of all devices is less than the sleep time. In the opposite case two or more “waves” of enabled devices will exist, but the function will still exist and work correctly. The reduced peak current consumption enables the possibility to design a module with narrower PCB traces and less filtering capacitance near the chip. This makes practical the possibility to make a module with hundreds of devices with more than 1m length and operate it close to the minimum supply voltage (e.g. at 5V) without worrying that the last chip in the module will not be able to operate because of the too high voltage drop over the PCB traces.

In case the SYNC-DISABLE connection between any two slave devices is broken, a new master is automatically assigned (the chip with the floating DISABLE pin) and the module continues to operate with two masters, one for the half of the chain before the defect and one for the half of the chain after the defect. No power-cycling is required or manual intervention. The average current consumption of a module operating in Daisy chain mode can be calculated using the following formula:

$$I_{DDAVG} = N \times I_{DDAVG\_SINGLE} + (N - 1) \times \frac{(I_{DIS\_WPD} \times (t_{SLEEP} + t_{PACT} + t_{ACT} - 65\mu s) + I_{DIS\_SPD} \times 65\mu s)}{t_{SLEEP} + t_{PACT} + t_{ACT}}$$

Where N is the number of devices in the Daisy chain, I<sub>DDAVG\_SINGLE</sub> is the average current consumption of a single chip calculated using the formula in “9.2 Average supply current”, I<sub>DIS\_WPD</sub> is the weak pull down current of the DISABLE pin, I<sub>DIS\_SPD</sub> is the DISABLE pin strong pull-down current, t<sub>SLEEP</sub> is the Sleep phase duration, t<sub>PACT</sub> is the Pre-Active phase duration and t<sub>ACT</sub> is the Active phase duration. Similar to the average current consumption of a single chip when minimum and maximum current consumption is calculated the timing tolerances should not be taken into account, only typical values should be used.

# MLX92362/MLX92361

Isolated output programmable Hall Effect Latch/Switch/Omnipolar switch  
Datasheet

## 10. Magnetic Behavior

### 10.1. Latch Sensor

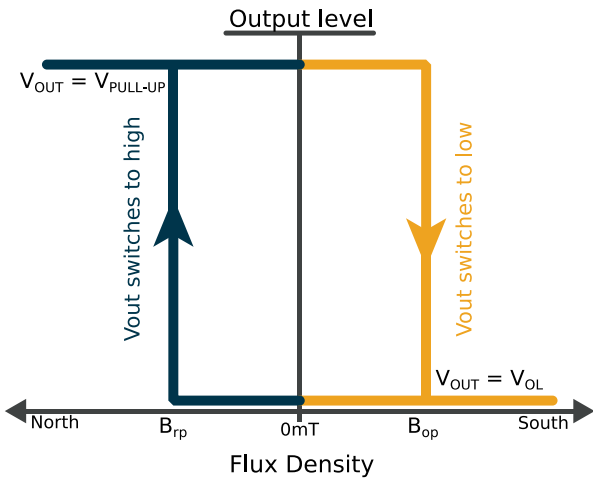

*South Pole Active Latch*

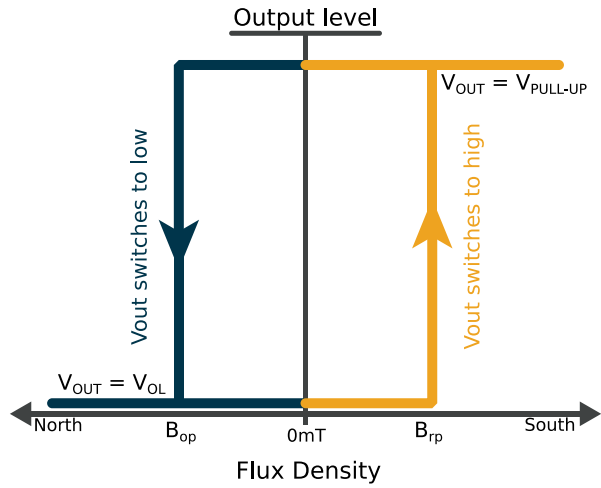

*North Pole Active Latch*

### 10.2. Unipolar Switch Sensor

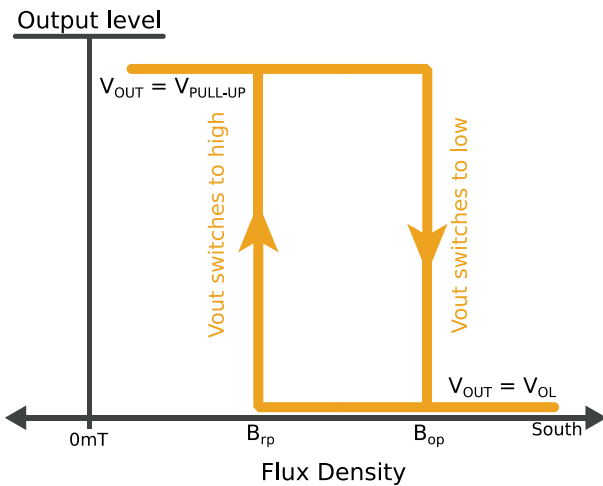

*Direct South Pole Active Switch*

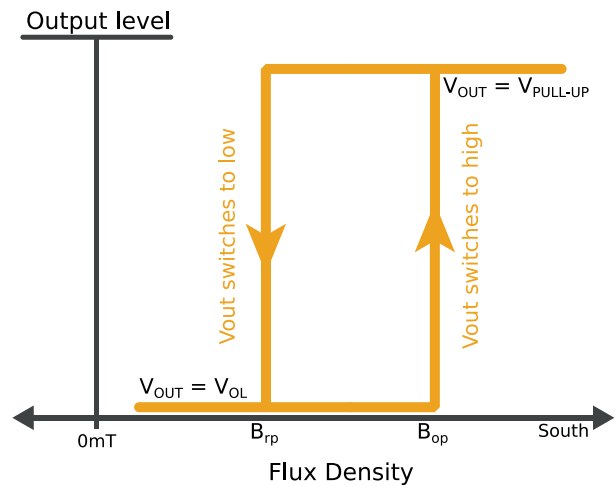

*Inverted South Pole Active Switch*

# MLX92362/MLX92361

Isolated output programmable Hall Effect Latch/Switch/Omnipolar switch  
Datasheet

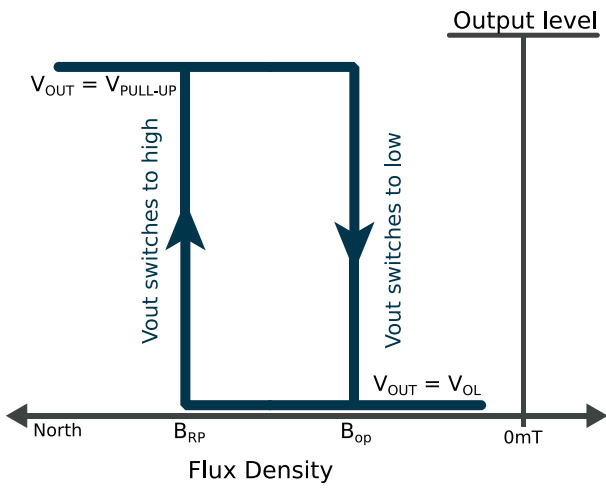

Direct North Pole Active Switch

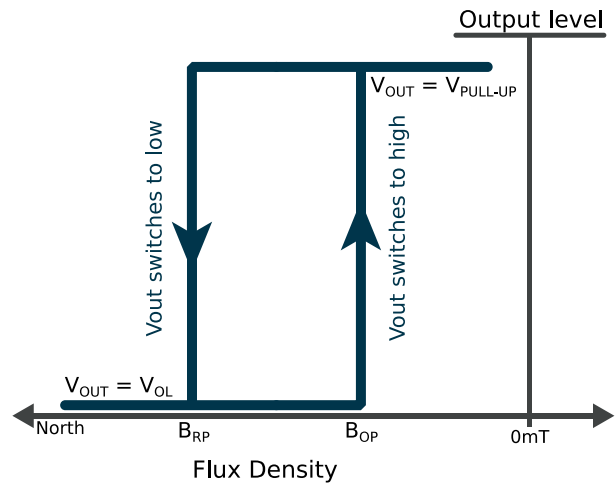

Inverted North Pole Active Switch

## 10.3. Omnipolar Switch Sensor

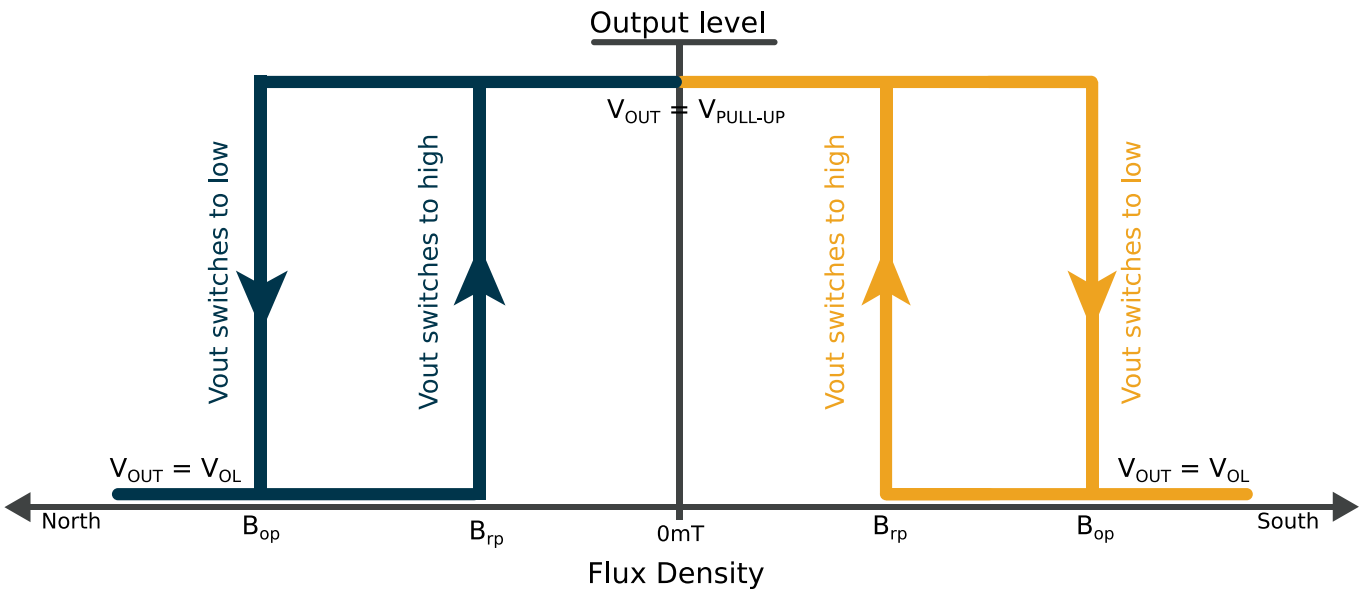

Direct omnipolar switch

# MLX92362/MLX92361

Isolated output programmable Hall Effect Latch/Switch/Omnipolar switch  
Datasheet

## 11. Open drain application schematics – Low side and High side

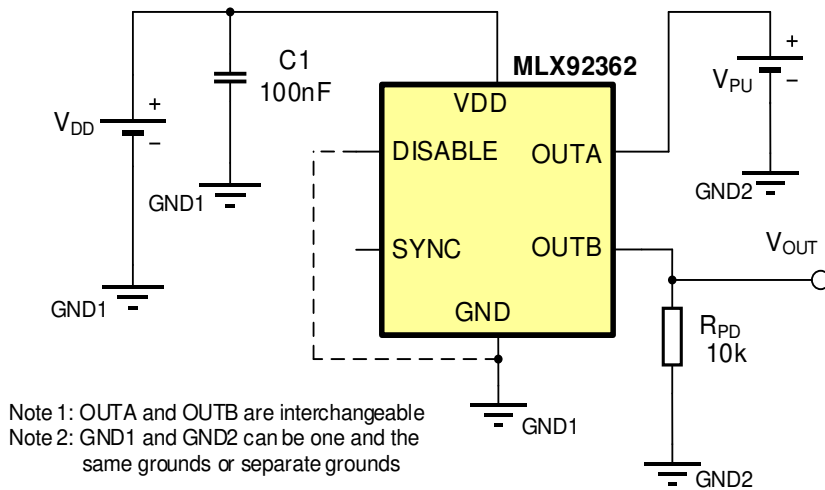
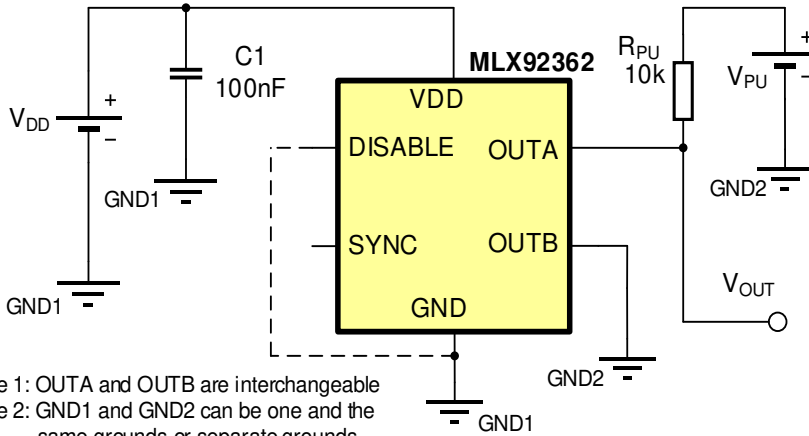

# MLX92362/MLX92361

Isolated output programmable Hall Effect Latch/Switch/Omnipolar switch  
Datasheet

## 12. Fluid level meter application schematic

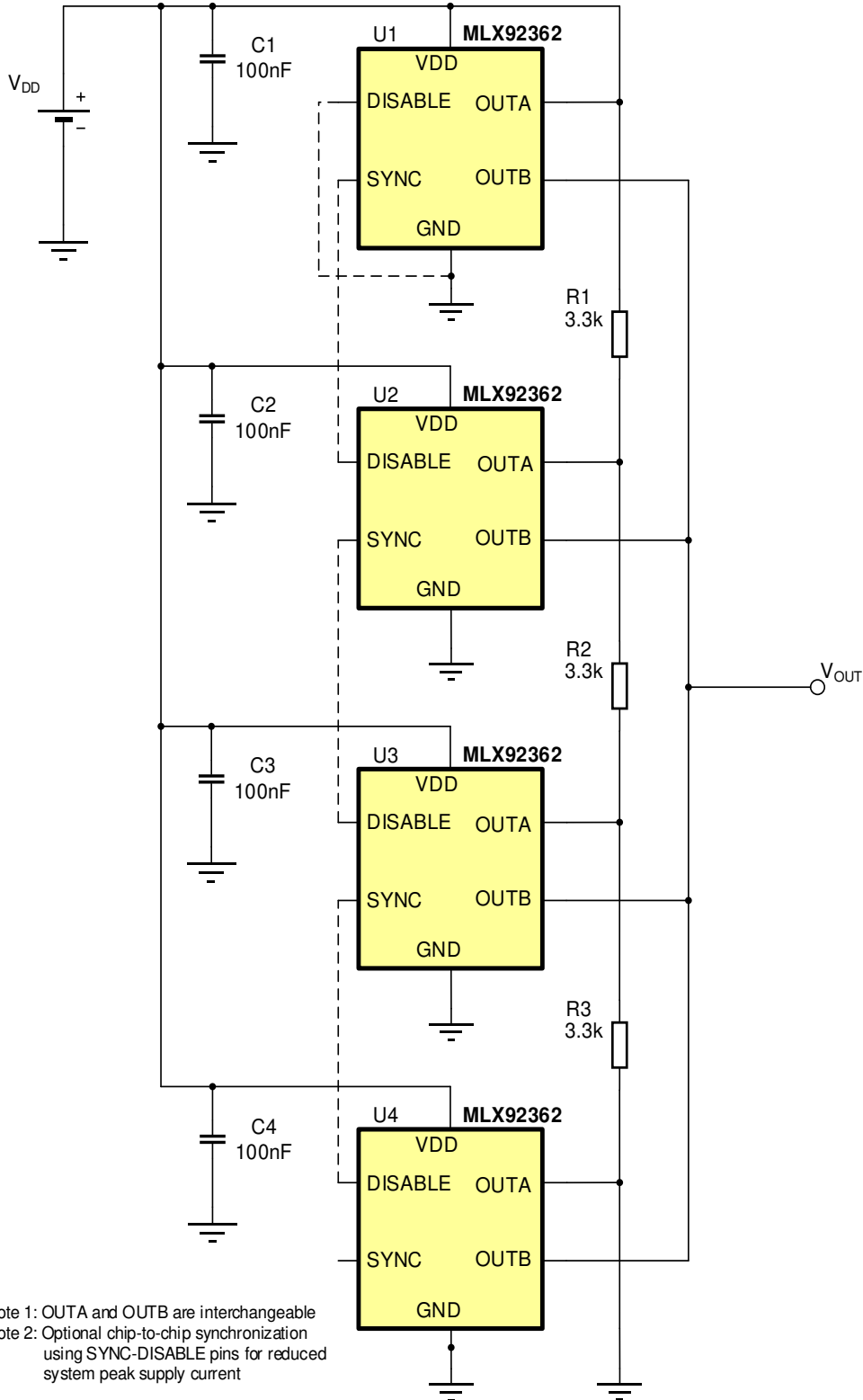

# MLX92362/MLX92361

Isolated output programmable Hall Effect Latch/Switch/Omnipolar switch  
 Datasheet

## 13. Package Information

### 13.1. TSOT-6L (SE Package)

#### 13.1.1. TSOT-6L – Package dimensions

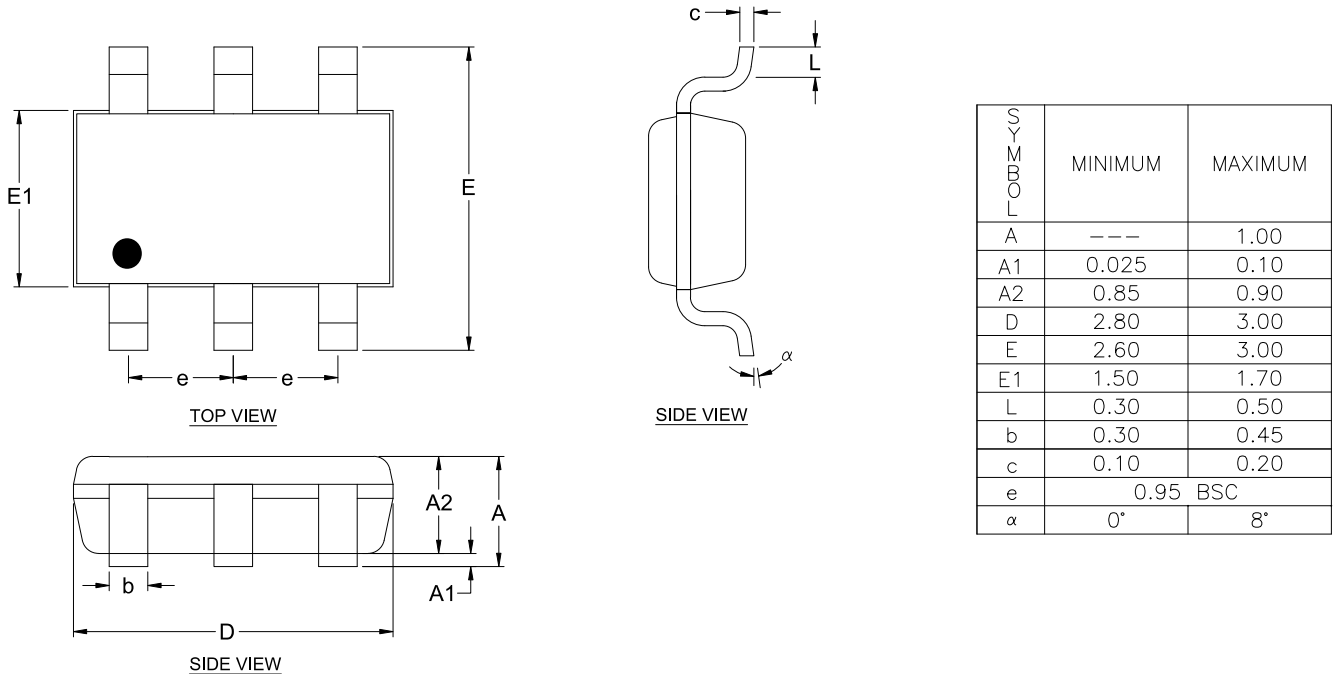

NOTE :

1. ALL DIMENSIONS IN MILLIMETERS (mm) UNLESS OTHERWISE STATED.
2. DIMENSION D DOES NOT INCLUDE MOLD FLASH OR PROTRUSIONS OF MAX 0.15 mm PER SIDE.
3. DIMENSION E DOES NOT INCLUDE MOLD FLASH OR PROTRUSIONS OF MAX 0.25 mm PER SIDE.
4. DIMENSION b DOES NOT INCLUDE DAMBAR PROTRUSION OF MAX 0.07 mm.
5. DIMENSION L IS THE LENGTH OF THE TERMINAL FOR SOLDERING TO A SUBSTRATE.
6. FORMED LEAD SHALL BE PLANAR WITH RESPECT TO ONE ANOTHER WITH 0.076 mm SEATING PLANE.

#### 13.1.2. TSOT-6L – Sensitive spot

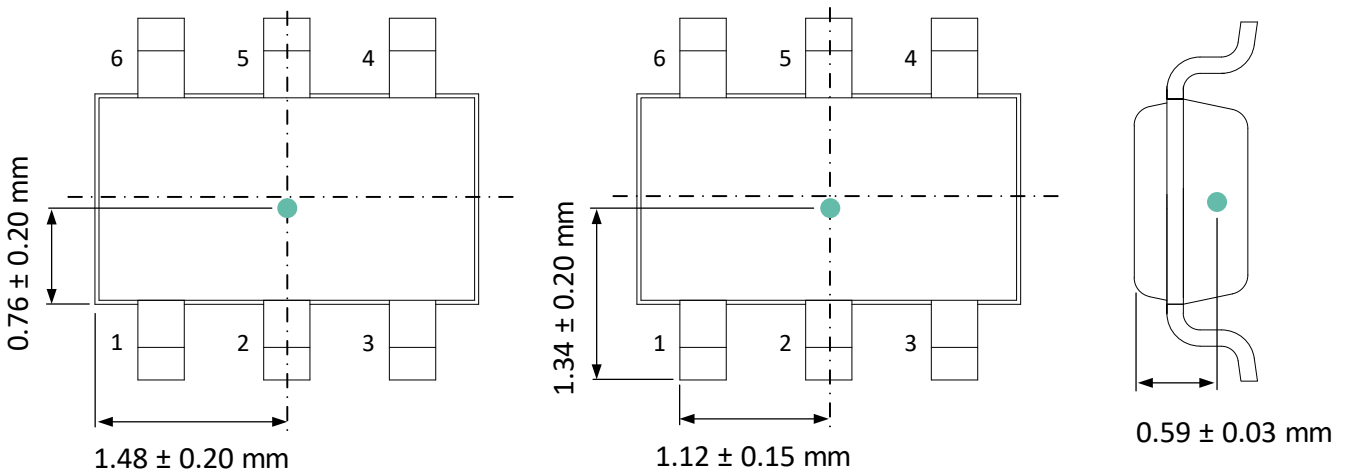

# MLX92362/MLX92361

Isolated output programmable Hall Effect Latch/Switch/Omnipolar switch  
Datasheet

## 13.1.3. TSOT-6L – Package marking/ Pin definition

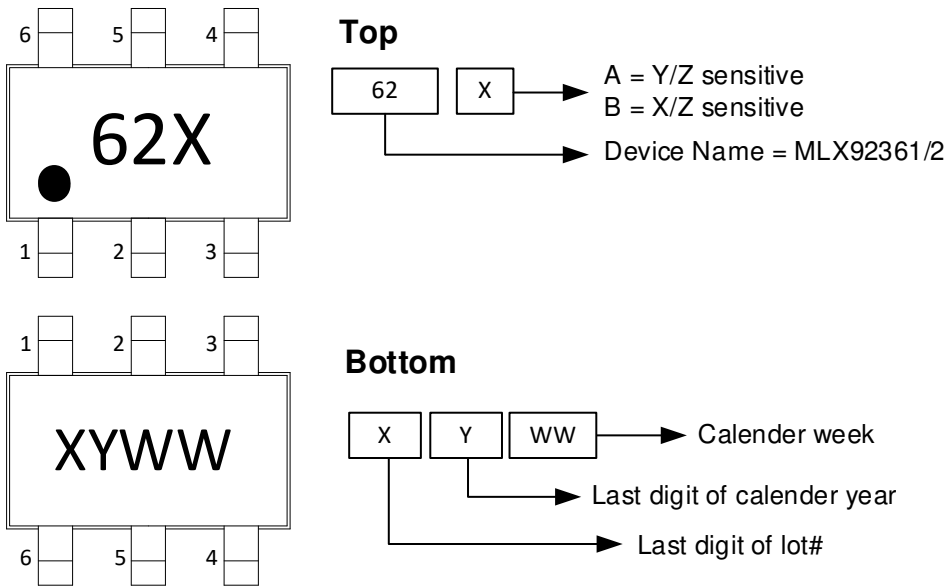

Pin #	Name	Type	Function
1	DISABLE	Input	Chip disable input. Integrated pull-down
2	GND	Ground	Ground pin
3	SYNC	Output	Synchronization output, push-pull
4	OUTA	Output	Isolated switch pin A
5	OUTB	Output	Isolated switch pin B
6	VDD	Supply	Supply Voltage pin

Note: if the Disable pin is unused, connect to ground or leave unconnected.



# MLX92362/MLX92361

Isolated output programmable Hall Effect Latch/Switch/Omnipolar switch  
Datasheet

## 14. Standard Information

Our products are classified and qualified regarding soldering technology, solderability and moisture sensitivity level according to standards in place in Semiconductor industry.

For further details about test method references and for compliance verification of selected soldering method for product integration, Melexis recommends reviewing on our web site the General Guidelines [soldering recommendation](#). For all soldering technologies deviating from the one mentioned in above document (regarding peak temperature, temperature gradient, temperature profile etc), additional classification and qualification tests have to be agreed upon with Melexis.

For package technology embedding trim and form post-delivery capability, Melexis recommends to consult the dedicated trim&form recommendation application note: [lead trimming and forming recommendations](#)

Melexis is contributing to global environmental conservation by promoting **lead free** solutions. For more information on qualifications of **RoHS** compliant products (RoHS = European directive on the Restriction Of the use of certain Hazardous Substances) please visit the quality page on our website: <http://www.melexis.com/en/quality-environment>

## 15. ESD Precautions

Electronic semiconductor products are sensitive to Electro Static Discharge (ESD).  
Always observe Electro Static Discharge control procedures whenever handling semiconductor products.

## 16. Contact

For the latest version of this document, go to our website at [www.melexis.com](http://www.melexis.com).  
For additional information, get in touch via [www.melexis.com/contact](http://www.melexis.com/contact)

## 17. Disclaimer

*The content of this document is believed to be correct and accurate. However, the content of this document is furnished "as is" for informational use only and no representation, nor warranty is provided by Melexis about its accuracy, nor about the results of its implementation. Melexis assumes no responsibility or liability for any errors or inaccuracies that may appear in this document. Customer will follow the practices contained in this document under its sole responsibility. This documentation is in fact provided without warranty, term, or condition of any kind, either implied or expressed, including but not limited to warranties of merchantability, satisfactory quality, non-infringement, and fitness for purpose. Melexis, its employees and agents and its affiliates' and their employees and agents will not be responsible for any loss, however arising, from the use of, or reliance on this document. Notwithstanding the foregoing, contractual obligations expressly undertaken in writing by Melexis prevail over this disclaimer.*

*This document is subject to change without notice, and should not be construed as a commitment by Melexis. Therefore, before placing orders or prior to designing the product into a system, users or any third party should obtain the latest version of the relevant information. Users or any third party must determine the suitability of the product described in this document for its application, including the level of reliability required and determine whether it is fit for a particular purpose.*

*This document as well as the product here described may be subject to export control regulations. Be aware that export might require a prior authorization from competent authorities. The product is not designed, authorized or warranted to be suitable in applications requiring extended temperature range and/or unusual environmental requirements. High reliability applications, such as medical life-support or life-sustaining equipment or avionics application are specifically excluded by Melexis. The product may not be used for the following applications subject to export control regulations: the development, production, processing, operation, maintenance, storage, recognition or proliferation of:*

- 1. chemical, biological or nuclear weapons, or for the development, production, maintenance or storage of missiles for such weapons;*
- 2. civil firearms, including spare parts or ammunition for such arms;*
- 3. defense related products, or other material for military use or for law enforcement;*
- 4. any applications that, alone or in combination with other goods, substances or organisms could cause serious harm to persons or goods and that can be used as a means of violence in an armed conflict or any similar violent situation.*

*No license nor any other right or interest is granted to any of Melexis' or third party's intellectual property rights.*

*If this document is marked "restricted" or with similar words, or if in any case the content of this document is to be reasonably understood as being confidential, the recipient of this document shall not communicate, nor disclose to any third party, any part of the document without Melexis' express written consent. The recipient shall take all necessary measures to apply and preserve the confidential character of the document. In particular, the recipient shall (i) hold document in confidence with at least the same degree of care by which it maintains the confidentiality of its own proprietary and confidential information, but no less than reasonable care; (ii) restrict the disclosure of the document solely to its employees for the purpose for which this document was received, on a strictly need to know basis and providing that such persons to whom the document is disclosed are bound by confidentiality terms substantially similar to those in this disclaimer; (iii) use the document only in connection with the purpose for which this document was received, and reproduce document only to the extent necessary for such purposes; (iv) not use the document for commercial purposes or to the detriment of Melexis or its customers. The confidentiality obligations set forth in this disclaimer will have indefinite duration and in any case they will be effective for no less than 10 years from the receipt of this document.*

*This disclaimer will be governed by and construed in accordance with Belgian law and any disputes relating to this disclaimer will be subject to the exclusive jurisdiction of the courts of Brussels, Belgium.*

*The invalidity or ineffectiveness of any of the provisions of this disclaimer does not affect the validity or effectiveness of the other provisions. The previous versions of this document are repealed.*

*Melexis © - No part of this document may be reproduced without the prior written consent of Melexis. (2022)*

*IATF 16949 and ISO 14001 Certified*