

REVISIONS				
P	LTR	DESCRIPTION	DATE	APVD
	H8	ECR-22-138429	18MAY2022	LP DSC

AMP
WIRE RANGE

18-16 AWG
STRANDED

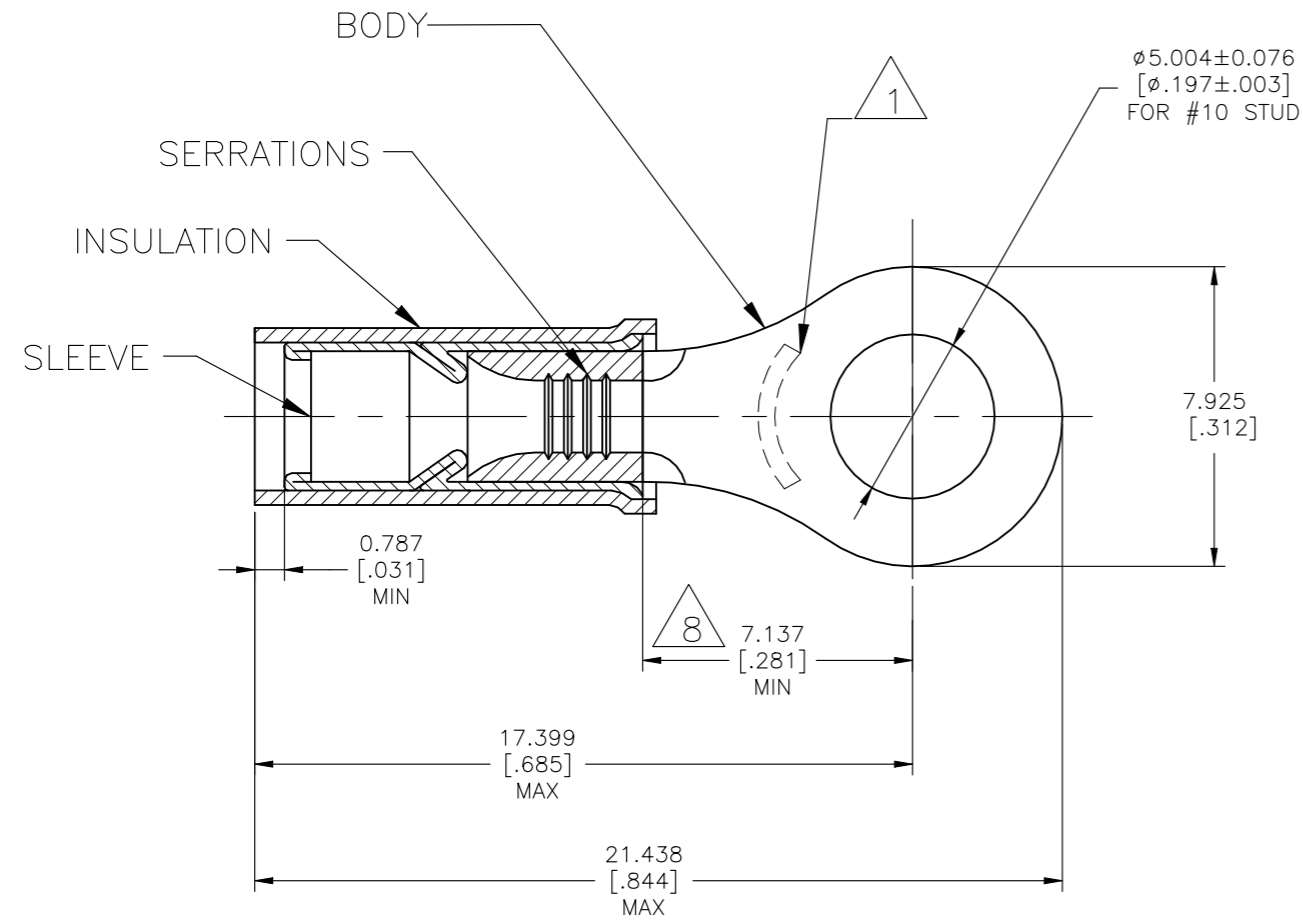

- 1 STAMP "AMP 18-16*" APPROX AS SHOWN
- 2 FOR 1.397[.055] TO 3.429[.135] WIRE INSULATION DIA.
- 3 BODY MATERIAL THK: 0.787 ± 0.051 [.031 \pm .002]
- 4 MATERIAL:
BODY & SLEEVE - COPPER PER ASTM B152
INSULATION - PTFE PER ASTM D4895
- 5 FINISH:
BODY - GOLD PLATE 0.00127[.00005] MIN EXT THK PER ASTM B488 TYPE 1, CODE C OVER NICKEL PLATE
0.00076[.00003] AVG EXT THK PER SAE AMS-QQ-N-290
SLEEVE - NICKEL PLATE 0.001651[.000065] AVG EXT THK PER SAE AMS-QQ-N-290
INSULATION COLOR - ORANGE
- 6 NOTE DELETED
- 7 NOTE DELETED
- 8 DIMENSION APPLIES FROM EDGE OF METAL WIRE BARREL TO CENTER OF STUD HOLE

1000	LOOSE PIECE	1-332454-0
PACKAGE QTY	PACKAGE TYPE	PART NO.

AMP INCORPORATED CUSTOMER SERVICE SYSTEMS		MAX RECOMMENDED OPERATING TEMPERATURE: 260°C [500°F]	THIS DRAWING IS A CONTROLLED DOCUMENT.		DWN JR RUTH 11JUL05	STE TE Connectivity				
FOR ADDITIONAL PRODUCT INFORMATION OR COPIES OF DRAWINGS AND TECHNICAL DOCUMENTS	PRODUCT INFORMATION CENTER 1-800-522-6752	VOLTAGE RATING: 300V MAX	DIMENSIONS: mm [INCHES]	TOLERANCES UNLESS OTHERWISE SPECIFIED:	CHK T MICHELUTTI 11JUL05				NAME	
FOR APPLICATION TOOLING INFORMATION	TOOLING ASSISTANCE CENTER 1-800-722-1111	CIRCULAR MIL AREA: 0.81-1.42mm ² [1,600-2,800] STRANDED WIRE ONLY		0 PLC ± - 1 PLC ± - 2 PLC ± - 3 PLC ± 0.127[.005] 4 PLC ± - ANGLES ± -	APVD T MICHELUTTI 11JUL05	TERMINAL, RING TONGUE, PIDG, STRATO-THERM, WIRE SIZE: 18-16 AWG				
FOR ORDER ENTRY	1-800-526-5142		MATERIAL	FINISH	PRODUCT SPEC -	APPLICATION SPEC 114-2162	SIZE A3	CAGE CODE 00779	DRAWING NO C-332454	RESTRICTED TO -
CUSTOMER DRAWING					WEIGHT -	SCALE 5:1	SHEET 1 OF 1	REV H8		