

TPS65311-Q1 High-Voltage Power-Management IC for Automotive Applications

1 Features

- Qualified for Automotive Applications
- AEC-Q100 Test Guidance With the Following Results:
 - Device Temperature Grade 1: -40°C to $+125^{\circ}\text{C}$ Ambient Operating Temperature
 - Device HBM ESD Classification Level H1B
 - Device CDM ESD Classification Level C4B
- Input Voltage Range: 4 V to 40 V, Transients up to 60 V; 80 V When Using External PMOS-FET
- Single-Output Synchronous-Buck Controller
 - Peak Gate-Drive Current 0.6 A
 - 490-kHz Fixed Switching Frequency
 - Pseudo Random Frequency-Hopping Spread Spectrum or Triangular Mode
- Dual-Synchronous Buck Converter
 - Designed for Output Currents up to 2 A
 - Out of Phase Switching
 - Switching Frequency: 2.45 MHz
- Adjustable 350-mA Linear Regulator
- Adjustable Asynchronous-Boost Converter
 - 1-A Integrated Switch
 - Switching Frequency: 2.45 MHz
- Soft-Start Feature for All Regulator Outputs
- Independent Voltage Monitoring
- Undervoltage (UV) Detection and Overvoltage (OV) Protection
- Short Circuit, Overcurrent, and Thermal Protection on all supply output rails
- Serial-Peripheral Interface (SPI) for Control and Diagnostic
- Integrated Window Watchdog (WD)
- Reference Voltage Output
- High-Side (HS) Driver for Use with External PMOS-FET for driving an LED
- Input for External Temperature Sensor for Shutdown at $T_A < -40^{\circ}\text{C}$
- Thermally Enhanced Packages With Exposed Thermal Pad
 - 56-Pin VQFN (RVJ) or 56-Pin VQFNP (RWE)

2 Applications

- Multi-Rail DC Power Distribution Systems
- Safety-Relevant Automotive Applications
 - Advanced Driver Assistance Systems

3 Description

The TPS65311-Q1 device is a power-management IC (PMIC), meeting the requirements of digital-signal-processor (DSP) controlled-automotive systems (for example, advanced driver-assistance systems). With the integration of commonly used supply rails and features, the TPS65311-Q1 device significantly reduces board space and system costs.

The device is capable of providing stable output voltages to the application, including a typical 5-V CAN-supply, from a varying input power supply (such as an automotive car battery) from 4 V to 40 V. The device includes one synchronous buck controller as a pre-regulator that offers flexible output power to the application. For post-regulation, the device includes two synchronous buck and one asynchronous boost converter, working at a switching frequency of 2.45 MHz to allow for a smaller inductor which requires less board space. The two buck converters also offer internal loop compensation which eliminates the need for external compensation components. Furthermore, the device includes a low-noise linear regulator.

Device Information⁽¹⁾

| DEVICE NAME | PACKAGE | BODY SIZE |
|-------------|------------|-------------------|
| TPS65311-Q1 | VQFN (56) | 8.00 mm × 8.00 mm |
| | VQFNP (56) | 8.00 mm × 8.00 mm |

(1) For all available packages, see the orderable addendum at the end of the data sheet.

Simplified Schematic

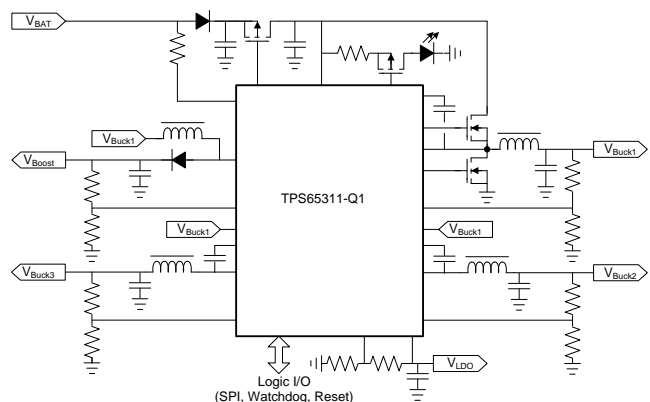

Copyright © 2017, Texas Instruments Incorporated



| | |
|--|----|
| • Added test condition for $I_{OUT} = 350 \text{ mA}$, $T_J = 150^\circ\text{C}$ to the $V_{Dropout}$ parameter in the <i>ELECTRICAL CHARACTERISTICS</i> table | 10 |
| • Changed the min value for the V_{HSSC_HY} parameter from 1.5 to 1 and deleted the typ (2.5) and max (3.5) values | 10 |
| • Moved all timing specifications from the <i>Electrical Characteristics</i> table into the <i>Timing Requirements</i> table and added figure references to the timing diagram | 13 |
| • Changed the max value for the $t_{VSSENSE_BLK}$ parameter from 20 to 35 | 13 |
| • Changed the MAX value for the WD filter time parameter from 0.5 μs to 1.2 μs in the <i>Timing Requirements</i> table | 14 |
| • Changed the min value for the t_{GL_BLK} parameter from 10 to 5 | 14 |
| • Moved all switching characteristics out of the <i>Electrical Characteristics</i> and into the new <i>Switching Characteristics</i> table | 15 |
| • Moved all but the first paragraph of the Description into the new <i>Overview</i> section in the <i>Detailed Description</i> section.... | 19 |
| • Moved the block diagram into the <i>Detailed Description</i> section | 20 |
| • Deleted the <i>Operating Modes</i> table and <i>Normal Mode PWM Operation</i> section title for Buck Controller (BUCK1)..... | 21 |
| • Changed the resistor name for the resistor next to C_1 from R_1 to R_3 and added R_1 and R_2 to the <i>Detailed Block Diagram of Buck 1 Controller</i> image | 21 |
| • Moved the component selection portion of the <i>Synchronous Buck Converters BUCK2 and BUCK3</i> section into the <i>Typical Applications</i> section | 22 |
| • Moved the component selection portion of the <i>BOOST Converter</i> section into the <i>Typical Applications</i> section | 22 |
| • Changed the voltage value that EXTSUP is connected to from 4.6 to 4.8 in the <i>Gate Driver Supply</i> section | 23 |
| • Moved the <i>SPI</i> section into a <i>Programming</i> section | 34 |
| • Added the <i>Design Parameters</i> tables for each of the <i>Typical Application</i> sections | 42 |
| • Added the <i>Adjusting the Output Voltage for the BUCK1 Controller</i> section to the <i>Buck Controller (BUCK1)</i> application section | 42 |
| • Moved the component selection portion of the <i>Buck Controller (BUCK1)</i> section into the <i>Typical Applications</i> section ... | 42 |
| • Changed $R1$ to $R3$ in the <i>Compensation of the Buck Controller</i> section | 43 |
| • Added the <i>Adjusting the Output Voltage for the BUCK2 and BUCK3 Converter</i> to the <i>Detailed Design Procedure</i> in the <i>Synchronous Buck Converters BUCK2 and BUCK3</i> section | 45 |
| • Changed the inductance, capacitance and FLC values from 3.3 μH , 20 μF , and 12.9 kHz to 1.5 μH , 39 μF , and 13.7 kHz (respectively) in the <i>For example:</i> section of the <i>Compensation of the BOOST Converter</i> section | 49 |
| • Added the <i>Linear Regulator</i> application section | 50 |
| • Added the <i>Device and Documentation Support</i> and <i>Mechanical, Packaging, and Orderable Information</i> sections. The <i>Device and Documentation Support</i> now includes the electrostatic discharge caution, trademark information, and a link to the TI Glossary..... | 55 |

Changes from Original (October 2013) to Revision A
Page

| | |
|--|----|
| • Changed document status from <i>Product Preview</i> to <i>Production Data</i> | 1 |
| • Deleted both min values (-44°C and -55°C) for T_J in the <i>RECOMMENDED OPERATING CONDITIONS</i> table..... | 8 |
| • Changed both max values for T_J from 150°C to 125°C in the <i>RECOMMENDED OPERATING CONDITIONS</i> table..... | 8 |
| • Changed condition statement of <i>ELECTRICAL CHARACTERISTICS</i> table from T_J temperature range to $T_{J(max)} = 125^\circ\text{C}$. 9 | |
| • Changed one test condition for the $V_{Dropout}$ parameter in the <i>ELECTRICAL CHARACTERISTICS</i> table from $T_J = 150^\circ\text{C}$ to $T_J = 125^\circ\text{C}$ | 10 |
| • Deleted the T_J temperature range from SHUTDOWN COMPARATOR subheader row in the <i>ELECTRICAL CHARACTERISTICS</i> table | 11 |
| • Changed one test condition for the I_{VT_leak} parameter in the <i>ELECTRICAL CHARACTERISTICS</i> table from $T_J = -20^\circ\text{C}$ to 150°C to $T_J = -20^\circ\text{C}$ to 125°C | 11 |
| • Changed the T_J temperature range to $T_{J(max)} = 125^\circ\text{C}$ for the INTERNAL VOLTAGE REGULATORS subheader row in the <i>ELECTRICAL CHARACTERISTICS</i> table | 12 |

5 Description (continued)

To help support system safety, the device includes voltage monitoring on all supply rails and a window-watchdog to monitor the MCU and DSP. Other features include a high-side driver which drives a warning-lamp LED, a reference voltage which is used as ADC reference in the MCU, DSP, and a shutdown comparator which, in combination with external NTC-resistor, switches off the device at too-low ambient temperature.

6 Pin Configuration and Functions

56-Pin VQFN and VQFN
RVJ and RWE Package With Exposed Thermal Pad
Top View

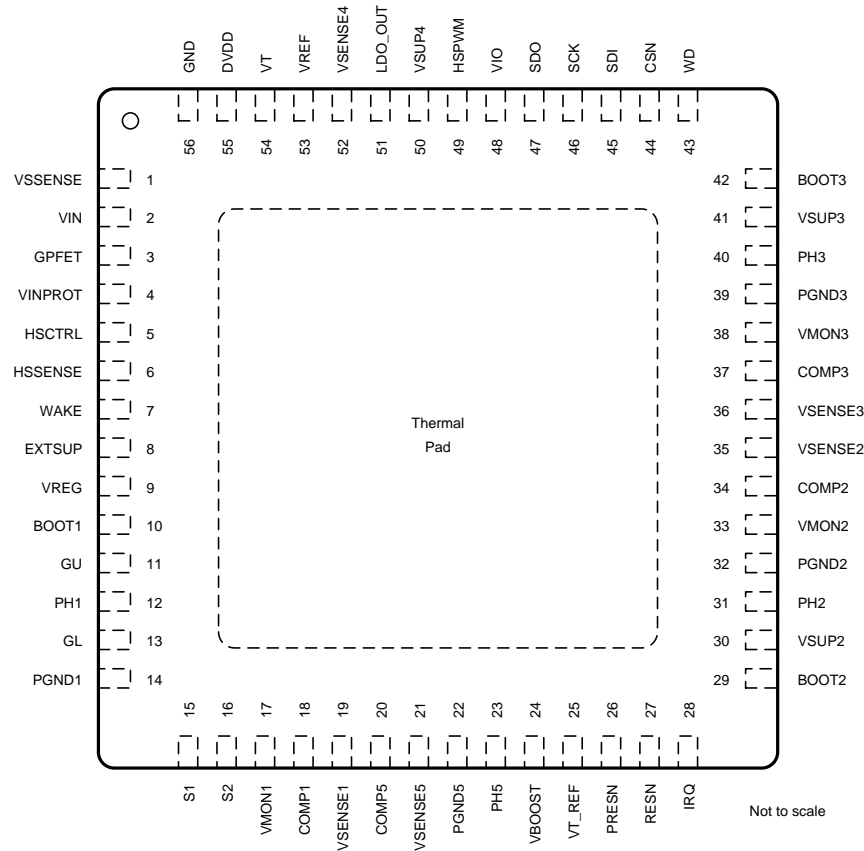

Pin Functions

| PIN | | TYPE ⁽¹⁾ | PULLUP OR PULLDOWN | DESCRIPTION |
|-------|-----|---------------------|--------------------|--|
| NAME | NO. | | | |
| BOOT1 | 10 | I | — | The capacitor on this pin acts as the voltage supply for the BUCK1 high-side MOSFET gate-drive circuitry. |
| BOOT2 | 29 | I | — | The capacitor on this pin acts as the voltage supply for the BUCK2 high-side MOSFET gate drive circuitry. |
| BOOT3 | 42 | I | — | The capacitor on this pin act as the voltage supply for the BUCK3 high-side MOSFET gate drive circuitry. |
| COMP1 | 18 | O | — | Error amplifier output for the switching controller. External compensation network is connected to this pin. |
| COMP2 | 34 | I | — | Compensation selection for the BUCK2 switching converter |
| COMP3 | 37 | I | — | Compensation selection for the BUCK3 switching converter. |
| COMP5 | 20 | O | — | Error amplifier output for the boost switching controller. External compensation network is connected to this pin. |
| CSN | 44 | I | Pullup | SPI – Chip select |

(1) Description of pin type: I = Input; O = Output; OD = Open-drain output

Pin Functions (continued)

| PIN | | TYPE ⁽¹⁾ | PULLUP OR PULLDOWN | DESCRIPTION |
|---------|-----|---------------------|--------------------|---|
| NAME | NO. | | | |
| DVDD | 55 | O | — | Internal DVDD output for decoupling |
| EXTSUP | 8 | I | — | Optional LV input for gate driver supply |
| GL | 13 | O | — | Gate driver – low-side FET |
| GND | 56 | O | — | Analog GND, digital GND and substrate connection |
| GPFET | 3 | O | — | Gate driver external protection PMOS FET. |
| GU | 11 | O | — | Gate driver – high-side FET |
| HSCTRL | 5 | O | — | High-side gate driver output |
| HSPWM | 49 | I | Pulldown | High side and LED PWM input |
| HSENSE | 6 | I | — | Sense input high side and LED |
| IRQ | 28 | OD | — | Low battery interrupt output in operating mode |
| LDO_OUT | 51 | O | — | Linear regulated output (connect a low ESR ceramic output capacitor to this pin) |
| PGND1 | 14 | O | — | Ground for low-side FET driver |
| PGND2 | 32 | O | — | Power ground of synchronous converter BUCK2 |
| PGND3 | 39 | O | — | Power ground of synchronous converter BUCK3 |
| PGND5 | 22 | O | — | Power ground boost converter |
| PH1 | 12 | O | — | Switching node - BUCK1 (floating ground for high-side FET driver) |
| PH2 | 31 | O | — | Switching node BUCK2 |
| PH3 | 40 | O | — | Switching node BUCK3 |
| PH5 | 23 | O | — | Switching node boost |
| PRESN | 26 | OD | — | Peripherals reset |
| RESN | 27 | OD | — | System reset |
| S1 | 15 | I | — | Differential current sense input for BUCK1 |
| S2 | 16 | I | Pulldown | Differential current sense input for BUCK1, pulldown only active in RAMP and ACTIVE state |
| SCK | 46 | I | Pulldown | SPI – Clock |
| SDI | 45 | I | Pulldown | SPI – Master out, slave in |
| SDO | 47 | O | — | SPI – Master in, slave out - push-pull output supplied by VIO |
| VBOOST | 24 | I | — | Booster output voltage |
| VIN | 2 | I | — | Unprotected supply input for the base functionality and band-gap 1. Supplied blocks are: RESET, WD, wake, SPI, temp sensing, voltage monitoring and the logic block. |
| VINPROT | 4 | I | — | Main input supply (gate drivers and bandgap2) |
| VIO | 48 | I | — | Supply input for the digital interface to the MCU. Voltage on this input is monitored. If VIO falls below UV threshold a reset is generated and the part enters error mode. |
| VMON1 | 17 | I | — | Input for the independent voltage monitor at BUCK1 |
| VMON2 | 33 | I | — | Input for the independent voltage monitor at BUCK2 |
| VMON3 | 38 | I | — | Input for the independent voltage monitor at BUCK3 |
| VREF | 53 | O | — | Accurate reference voltage output for peripherals on the system (for example, ADC) |
| VREG | 9 | O | — | Internal regulator for gate driver supply (decoupling) and VREF |
| VSENSE1 | 19 | I | — | Input for externally sensed voltage of the output using a resistor divider network from their respective output line to ground. |
| VSENSE2 | 35 | I | — | Input for externally sensed voltage of the output using a resistor divider network from their respective output line to ground |
| VSENSE3 | 36 | I | — | Input for externally sensed voltage of the output using a resistor divider network from their respective output line to ground |
| VSENSE4 | 52 | I | — | Input for externally sensed voltage of the output using a resistor divider network from their respective output line to ground. |
| VSENSE5 | 21 | I | — | Input for externally sensed voltage of the boost output using a resistor divider network from their respective output line to ground. |
| VSENSE | 1 | I | — | Input to monitor the battery line for undervoltage conditions. UV is indicated by the IRQ pin. |
| VSUP2 | 30 | I | — | Input voltage supply for switch mode regulator BUCK2 |
| VSUP3 | 41 | I | — | Input voltage supply for switch mode regulator BUCK3 |
| VSUP4 | 50 | I | — | Input voltage supply for linear regulator LDO |

Pin Functions (continued)

| PIN | | TYPE ⁽¹⁾ | PULLUP OR PULLDOWN | DESCRIPTION |
|--------|-----|---------------------|--------------------|---|
| NAME | NO. | | | |
| VT | 54 | I | — | Input for the comparator with shutdown functionality. This input can be used to sense an external NTC resistor to shutdown the IC in case the ambient temperature is too high or too low. Tie to GND if not in use. |
| VT_REF | 25 | O | — | Shutdown comparator reference output. Internally connected to DVDD, current-limited. When not in use can be connected to DVDD or left open. |
| WAKE | 7 | I | Pulldown | Wake up input |
| WD | 43 | I | Pulldown | Watchdog input. WD is the trigger input coming from the MCU. |

7 Specifications

7.1 Absolute Maximum Ratings

over operating free-air temperature range (unless otherwise noted)⁽¹⁾

| | | MIN | MAX | UNIT |
|---------------------|-------------------------------|-----------------------------------|--|------|
| Supply inputs | VIN | -0.3 | 80 | V |
| | VINPROT | -0.3 | 60 | |
| | VSUP2, 3 (BUCK2 and 3) | -0.3 | 20 | |
| | VSUP4 (Linear Regulator) | -0.3 | 20 | |
| | VBOOST | -0.3 | 20 | |
| | EXTSUP | -0.3 | 13 | |
| | VIO | -0.3 | 5.5 | |
| Buck controller | PH1 | -1 -2 for 100 ns | 60 | V |
| | VSENSE1 | -0.3 | 20 | |
| | COMP1 | -0.3 | 20 | |
| | GU-PH1, GL-PGND1, BOOT1-PH1 | -0.3 | 8 | |
| | S1, S2 | -0.3 | 20 | |
| | S1-S2 | -2 | 2 | |
| | BOOT1 | -0.3 | 68 | |
| | VMON1 | -0.3 | 20 | |
| Buck controller | BOOT2, BOOT3 | -1 | 20 | V |
| | PH2, PH3 | -1 ⁽²⁾ -2 for 10 ns | 20 ⁽²⁾ | |
| | VSENSE2, VSENSE3 | -0.3 | 20 | |
| | COMP2, COMP3 | -0.3 | 20 | |
| | VMON2, VMON3 | -0.3 | 20 | |
| | BOOTx – PHx | -0.3 | 8 | |
| Linear regulator | LDO_OUT | -0.3 | 8 | V |
| | VSENSE4 | -0.3 | 20 | |
| Boost converter | VSENSE5 | -0.3 | 20 | V |
| | PH5 | -0.3 | 20 | |
| | COMP5 | -0.3 | 20 | |
| Digital interface | CSN, SCK, SDO, SDI, WD, HSPWM | -0.3 | 5.5 | V |
| | RESN, PRESN, IRQ | -0.3 | 20 | |
| Wake input | WAKE | -1 ⁽³⁾ | 60 | V |
| Protection FET | GPFET | -0.3 | 80 | V |
| | VIN – GPFET | -0.3 | 20 | |
| Battery sense input | VSENSE | -1 ⁽³⁾ | 60 Transients up to 80 V ⁽⁴⁾ | V |
| Temperature sense | VT | -0.3 | 5.5 | V |
| | VT_REF | -0.3 | 20 | |

(1) Stresses beyond those listed under *Absolute Maximum Ratings* may cause permanent damage to the device. These are stress ratings only and functional operation of the device at these or any other conditions beyond those indicated under *Recommended Operating Conditions* is not implied. Exposure to absolute-maximum-rated conditions for extended periods may affect device reliability.

(2) Maximum 3.5 A

(3) I_{max} = 100 mA

(4) Internally clamped to 60-V, 20-kΩ external resistor required, current into pin limited to 1 mA.

Absolute Maximum Ratings (continued)

 over operating free-air temperature range (unless otherwise noted)⁽¹⁾

| | | MIN | MAX | UNIT |
|--------------------------|------------------------------------|------|-----|------|
| Reference voltage | VREF | -0.3 | 5.5 | V |
| High-side and LED driver | HSENSE | -0.3 | 60 | V |
| | HSCTRL | -0.3 | 60 | |
| | VINPROT-HSENSE, VINPROT-HSCTRL | -0.3 | 20 | |
| Driver supply decoupling | VREG | -0.3 | 8 | V |
| Supply decoupling | DVDD | -0.3 | 3.6 | V |
| Temperature ratings | Junction temperature range, T_J | -55 | 150 | °C |
| | Operating temperature range, T_A | -55 | 125 | |
| | Storage temperature, T_{stg} | -55 | 165 | |

7.2 ESD Ratings

| | | | VALUE | UNIT |
|-------------------------------------|---|---|-------|------|
| $V_{(ESD)}$ Electrostatic discharge | Human-body model (HBM), per AEC Q100-002 ⁽¹⁾ | | ±1000 | V |
| | | VT pin | ±150 | |
| | Charged-device model (CDM), per AEC Q100-011 | Corner pins (1, 14, 15, 28, 29, 42, 43, and 56) | ±750 | |
| | | All other pins | ±500 | |

(1) AEC Q100-002 indicates that HBM stressing shall be in accordance with the ANSI/ESDA/JEDEC JS-001 specification.

7.3 Recommended Operating Conditions

over operating free-air temperature range (unless otherwise noted)

| | | | MIN | NOM | MAX | UNIT |
|--|--|--|-----|-----|-----|------|
| Supply voltage at VIN, VINPROT, VSSENSE | | | 4.8 | | 40 | V |
| T_A Operating free air temperature | All electrical characteristics in specification | | -40 | | 125 | °C |
| | Shutdown comparator and internal voltage regulators in specification | | -55 | | 125 | |
| T_J Operating virtual junction temperature | All electrical characteristics in specification | | | | 150 | °C |
| | Shutdown comparator and internal voltage regulators in specification | | | | 150 | |

7.4 Thermal Information

| THERMAL METRIC ⁽¹⁾ | | TPS65311-Q1 | | UNIT |
|-------------------------------|--|-------------|------------|------|
| | | RWE (VQFN) | RVJ (VQFN) | |
| | | 56 PINS | 56 PINS | |
| $R_{\theta JA}$ | Junction-to-ambient thermal resistance | 22.1 | 22.3 | °C/W |
| $R_{\theta JC(top)}$ | Junction-to-case (top) thermal resistance | 9.6 | 9.8 | °C/W |
| $R_{\theta JB}$ | Junction-to-board thermal resistance | 6.2 | 6.3 | °C/W |
| Ψ_{JT} | Junction-to-top characterization parameter | 0.1 | 0.1 | °C/W |
| Ψ_{JB} | Junction-to-board characterization parameter | 6.2 | 6.2 | °C/W |
| $R_{\theta JC(bot)}$ | Junction-to-case (bottom) thermal resistance | 0.4 | 0.7 | °C/W |

(1) For more information about traditional and new thermal metrics, see the [Semiconductor and IC Package Thermal Metrics](#) application report.

7.5 Electrical Characteristics

VIN = VINPROT 4.8 V to 40 V, VSUPx = 3 V to 5.5 V, EXTSUP = 0 V, T_{J(max)} = 150°C, unless otherwise noted

| PARAMETER | | TEST CONDITIONS | MIN | TYP | MAX | UNIT |
|---|---|--|------|-------|------|------|
| INPUT VOLTAGE-CURRENT CONSUMPTION | | | | | | |
| V _{IN} | Device operating range | Buck regulator operating range, Voltage on VIN and VINPROT pins | 4 | | 50 | V |
| V _{POR} | Power-on reset threshold | Falling VIN | 3.5 | 3.6 | 3.8 | V |
| | | Rising VIN | 3.9 | 4.2 | 4.3 | |
| V _{POR_hyst} | Power-on reset hysteresis on VIN | | 0.47 | 0.6 | 0.73 | V |
| I _{LPM0} | LPM0 current consumption ⁽¹⁾⁽²⁾ | All off, wake active, V _{IN} = 13 V Total current into VSSENSE, VIN and VINPROT | | | 44 | μA |
| I _{LPM0} | LPM0 current (commercial vehicle application) consumption ⁽³⁾⁽²⁾ | All off, wake active, V _{IN} = 24.5 V Total current into VSSENSE, VIN and VINPROT | | | 60 | μA |
| I _{ACTIVE1} | ACTIVE total current consumption ⁽¹⁾⁽⁴⁾ | BUCK1 = on, V _{IN} = 13 V, EXTSUP = 0 V, Q _g of BUCK1 FETs = 15 nC. Total current into VSSENSE, VIN and VINPROT | | 32 | | mA |
| I _{ACTIVE123} | ACTIVE total current consumption ⁽¹⁾⁽⁴⁾ | BUCK1/2/3 = on, V _{IN} = 13 V, Q _g of BUCK1 FETs = 15 nC. Total current into VSSENSE, VIN and VINPROT | | 40 | | mA |
| I _{ACTIVE1235} | ACTIVE current consumption ⁽¹⁾⁽⁴⁾ | BUCK1/2/3, LDO, BOOST, high-side switch = on, V _{IN} = 13 V, Q _g of BUCK1 FETs = 15 nC. EXTSUP = 5 V from BOOST Total current into VSSENSE, VIN and VINPROT | | 31 | | mA |
| I _{ACTIVE1235_noEXT} | ACTIVE current consumption ⁽¹⁾⁽⁴⁾ | BUCK1/2/3, LDO, BOOST, high-side switch = on, V _{IN} = 13 V, Q _g of BUCK1 FETs = 15 nC, EXTSUP = open Total current into VSENSE, VIN and VINPROT | | 53 | | mA |
| BUCK CONTROLLER (BUCK1) | | | | | | |
| V _{BUCK1} | Adjustable output voltage range | | 3 | | 11 | V |
| V _{Sense1_NRM} | Internal reference voltage in operating mode | VSENSE1 pin, load = 0 mA, Internal REF = 0.8 V | -1% | | 1% | |
| V _{S1-2} | VS1-2 for forward OC in CCM | Maximum sense voltage VSENSE1 = 0.75 V (low duty cycle) | 60 | 75 | 90 | mV |
| | | Minimum sense voltage VSENSE1 = 1 V (negative current limit) | -65 | -37.5 | -23 | |
| A _{CS} | Current sense voltage gain | ΔVCOMP1 / Δ (VS1 - VS2) | 4 | 8 | 12 | V/V |
| I _{Gpeak} | Gate driver peak current | VREG = 5.8 V | | 0.6 | | A |
| R _{DSON_DRIVER} | Source and sink driver | I _G current for external MOSFET = 200 mA, VREG = 5.8 V, V _{BOOT1-PH1} = 5.8 V | | 5 | 10 | Ω |
| V _{DIO1} | Bootstrap diode forward voltage | I _{BOOT1} = -200 mA, VREG-BOOT1 | 0.8 | | 1.1 | V |
| ERROR AMPLIFIER (OTA) FOR BUCK CONTROLLERS AND BOOST CONVERTER | | | | | | |
| g _{mEA} | Forward transconductance | COMP1/2/3/5 = 0.8 V; source/sink = 5 μA, Test in feedback loop | | 0.9 | | mS |
| A _{EA} | Error amplifier DC gain | | 60 | | | dB |
| SYNCHRONOUS BUCK CONVERTER BUCK2 AND BUCK3 (BUCK2/3) | | | | | | |
| VSUP2/3 | Supply voltage | | 3 | | 11 | V |
| V _{BUCK2/3} | Regulated output voltage range | I _{load} = 0...2 A VSUPx = V _{BUCK2/3} + I _{load} × 0.2 Ω | 0.8 | | 5.5 | V |
| R _{DSON-HS} | R _{DSON} high-side switch | V _{BOOTx -PHx} = 5.8 V | | | 0.20 | Ω |
| R _{DSON-LS} | R _{DSON} low-side switch | VREG = 5.8 V | | | 0.20 | Ω |
| I _{HS-Limit} | High-side switch current-limit | Static current limit test. In application L > 1 μH at I _{HS-Limit} and I _{LS-Limit} to limit di / dt | 2.5 | 2.9 | 3.3 | A |
| I _{LS-Limit} | Low-side switch current-limit | Static current limit test. In application L > 1 μH at I _{HS-Limit} and I _{LS-Limit} to limit di / dt | 2 | 2.5 | 3 | A |

(1) T_A = 25°C

(2) Quiescent Current Specification does not include the current flow through the external feedback resistor divider. Quiescent Current is non-switching current, measured with no load on the output with V_{BAT} = 13 V.

(3) T_A = 130°C

(4) Total current consumption measured on EVM includes switching losses.

Electrical Characteristics (continued)

 VIN = VINPROT 4.8 V to 40 V, VSUPx = 3 V to 5.5 V, EXTSUP = 0 V, T_{J(max)} = 150°C, unless otherwise noted

| PARAMETER | | TEST CONDITIONS | MIN | TYP | MAX | UNIT |
|---|---|--|----------------|-------|------------|--------------------------|
| VSUP _{Lkg} | VSUP leakage current | VSUP = 10 V for high side, controller disabled, T _J = 100°C | | 1 | 2 | μA |
| V _{Sense2/3} | Feedback voltage | With respect to the 800-mV internal reference | -1% | | 1% | |
| COMP2/3 _H TH | COMP2/3 Input threshold low | | 0.9 | | 1.5 | V |
| COMP2/3 _L TH | COMP2/3 Input threshold high | | VREG - 1.2 | | VREG - 0.3 | V |
| R _{TIEOFF COMP23} | COMP2/3 internal tie-off | BUCK2/3 enabled. Resistor to VREG and GND, each | 70 | 100 | 130 | kΩ |
| V _{DIO2 3} | Bootstrap diode forward voltage | I _{BOOT1} = -200 mA, VREG-BOOT2, VREG-BOOT3 | | 1.1 | 1.2 | V |
| BOOST CONVERTER | | | | | | |
| V _{Boost} | Boost adjustable output voltage range | Using 3.3-V input voltage, leak_switch ≤ 1 A | 4.5 | | 15 | V |
| V _{Boost} | Boost adjustable output voltage range | Using 3.3-V input voltage I _{loadmax} = 20 mA, I _{peak_switch} = 0.3 A | 15 | | 18.5 | V |
| R _{DS-ON_BOOST} | Internal switch on-resistance | VREG = 5.8 V | | 0.3 | 0.5 | Ω |
| V _{Sense5} | Feedback voltage | With respect to the 800-mV internal reference | -1% | | 1% | |
| I _{CLBOOST} | Internal switch current-limit | | 1 | | 1.5 | A |
| LINEAR REGULATOR LDO | | | | | | |
| VSUP4 | Device operating range for LDO | Recommended operating range | 3 | | 7 | V |
| V _{LDO} | Regulated output range | I _{OUT} = 1 mA to 350 mA | 0.8 | | 5.25 | V |
| V _{RefLDO} | DC output voltage tolerance at VSENSE4 | VSENSE4 = 0.8 V (regulated at internal ref) VSUP4 = 3 V to 7 V, I _{OUT} = 1 mA to 350 mA | -2% | | 2% | |
| V _{step1} | Load step 1 | VSENSE4 = 0.8 V (regulated at internal ref) I _{OUT} = 1 mA to 101 mA, C _{LDO} = 6 to 50 μF, t _{rise} = 1 μs | -2% | | 2% | |
| V _{Sense4} | Feedback voltage | With respect to the 800-mV internal reference | -1% | | 1% | |
| V _{Dropout} | Drop out voltage | I _{OUT} = 350 mA, T _J = 25°C | | 127 | 143 | mV |
| | | I _{OUT} = 350 mA, T _J = 125°C | | 156 | 180 | |
| | | I _{OUT} = 350 mA, T _J = 150°C | | 275 | 335 | |
| I _{OUT} | Output current | V _{OUT} in regulation | -350 | | -1 | mA |
| I _{LDO-CL} | Output current limit | V _{OUT} = 0 V, VSUP4 = 3 V to 7 V | -1000 | | -400 | mA |
| PSRR _{LDO} | Power supply ripple rejection | V _{ripple} = 0.5 V _{PP} , I _{OUT} = 300 mA, C _{LDO} = 10 μF | Freq = 100 Hz | | 60 | dB |
| | | | Freq = 4 kHz | | 50 | |
| | | | Freq = 150 kHz | | 25 | |
| LDOns ₁₀₋₁₀₀ | Output noise 10 Hz – 100 Hz | 10-μF output capacitance, V _{LDO} = 2.5 V | | | 20 | μV/√(Hz) |
| LDOns _{100-1k} | Output noise 100 Hz – 10 kHz | 10-μF output capacitance, V _{LDO} = 2.5 V | | | 6 | μV/√(Hz) |
| C _{LDO} | Output capacitor | Ceramic capacitor with ESR range, C _{LDO_ESR} = 0 to 100 mΩ | 6 | | 50 | μF |
| LED AND HIGH-SIDE SWITCH CONTROL | | | | | | |
| V _{HSENSE} | Current sense voltage | VINPROT – HSENSE, high-side switch in current limit | 370 | 400 | 430 | mV |
| V _{CMHSENSE} | Common mode range for current sensing | See VINPROT | 4 | | 60 | V |
| V _{HSOL_TH} | VINPROT – HSENSE open load threshold | Ramping negative | 5 | 20 | 35 | mV |
| | | Ramping positive | 26 | 38 | 50 | |
| V _{HSOL_HY} | Open load hysteresis | | 10 | 18 | 28 | mV |
| V _{HS_SC} | VINPROT – HSENSE load short detection threshold | Ramping positive | 88% | 92.5% | 96% | V _{HSENSE} |
| | | Ramping negative from load short condition | 87 | 90 | 93 | % of V _{HSENSE} |
| V _{HSSC_HY} | VINPROT – HSENSE short circuit hysteresis | | 1 | | | % of V _{HSENSE} |
| V _{HSCTRL_{OFF}} | Voltage at HSCTRL when OFF | | VINPROT - 0.5 | | VINPROT | V |
| V _{GS} | Clamp voltage between HSENSE – HSCTRL | | 6.1 | 7.7 | 8.5 | V |

Electrical Characteristics (continued)

 VIN = VINPROT 4.8 V to 40 V, VSUPx = 3 V to 5.5 V, EXTSUP = 0 V, T_{J(max)} = 150°C, unless otherwise noted

| PARAMETER | TEST CONDITIONS | MIN | TYP | MAX | UNIT | | | |
|----------------------------------|--|---|-----|------|------|----------|------|--------------------|
| V _{OS_HS} | Overshoot during turn-on | V _{OS_HS} = VINPROT - HSENSE | | | 400 | mV | | |
| I _{CL_HSCTRL} | HSCTRL current-limit | 2 | 4.1 | 5 | mA | | | |
| R _{PU_HSCTRL} | Internal pullup resistors | Between VINPROT and HSCTRL | | | 70 | 100 | 130 | kΩ |
| R _{PU_HSCTRL-HSENSE} | | Between HSCTRL and HSENSE | | | 70 | 100 | 130 | |
| V _{I_high} | High level input voltage | HSPWM, VIO = 3.3 V | | | 2 | | V | |
| V _{I_low} | Low level input voltage | HSPWM, VIO = 3.3 V | | | | 0.8 | V | |
| V _{I_hys} | Input voltage hysteresis | HSPWM, VIO = 3.3 V | | | 150 | 500 | mV | |
| R _{SENSE} | External sense resistor | Design info, no device parameter | | | 1.5 | 50 | Ω | |
| C _{GS} | External MOSFET gate source capacitance | 100 | | 2000 | | pF | | |
| C _{GD} | External MOSFET gate drain capacitance | | | 500 | | pF | | |
| REFERENCE VOLTAGE | | | | | | | | |
| V _{REF} | Reference voltage | | | | 3.3 | V | | |
| V _{REF-tol} | Reference voltage tolerance | I _{VREF} = 5 mA | | | -1% | 1% | | |
| I _{REFCL} | Reference voltage current-limit | 10 | | 25 | mA | | | |
| C _{VREF} | Capacitive load | 0.6 | | 5 | μF | | | |
| REFns10-100 | Output noise 10 Hz–100 Hz | 2.2 μF output capacitance, I _{VREF} = 5 mA | | | 20 | μV/√(Hz) | | |
| REFns100-1k | Output noise 100 Hz–10 kHz | 2.2 μF output capacitance, I _{VREF} = 5 mA | | | 6 | μV/√(Hz) | | |
| V _{REF_OK} | Reference voltage OK threshold | Threshold, V _{REF} falling | | | 2.91 | 3.07 | 3.12 | V |
| | | Hysteresis | | | 14 | 70 | 140 | mV |
| SHUTDOWN COMPARATOR | | | | | | | | |
| V _{T_REF} | Shutdown comparator reference voltage | I _{VT_REF} = 20 μA. Measured as drop voltage with respect to VD _{VDD} | | | 10 | 17 | 500 | mV |
| | | I _{VT_REF} = 600 μA. Measured as drop voltage with respect to VD _{VDD} . No V _{T_REF} short-circuit detection. | | | 200 | 420 | 1100 | |
| I _{VT_REFCL} | Shutdown comparator reference current limit | V _{T_REF} = 0 | | | 0.6 | 1 | 1.4 | mA |
| V _{VT_REF SH} | V _{T_REF} short circuit detection | Threshold, V _{T_REF} falling. Measured as drop voltage with respect to VD _{VDD} | | | 0.9 | 1.2 | 1.8 | V |
| | | Hysteresis | | | | 130 | | mV |
| V _{TTH-H} | Input voltage threshold on V _T , rising edge triggers shutdown | This feature is specified by design to work down to -55°C. | | | 0.48 | 0.50 | 0.52 | V _{T_REF} |
| V _{TTH-L} | Input voltage threshold on V _T , falling voltage enables device operation | This feature is specified by design to work down to -55°C. | | | 0.46 | 0.48 | 0.52 | V _{T_REF} |
| V _{TOL} | Threshold variation | V _{TTH-H} - V _{T_REF} / 2, V _{TTH-L} - V _{T_REF} / 2 | | | -20 | | 20 | mV |
| I _{VT_leak} | Leakage current | T _J : -20°C to 125°C | | | -400 | | -50 | nA |
| | | T _J : -55°C to -20°C | | | -200 | | -50 | |
| V _{T_REF_OV} | V _{T_REF} overvoltage threshold | Threshold, V _{T_REF} rising. Measured as drop voltage with respect to VD _{VDD} | | | 0.42 | 0.9 | 1.2 | V |
| | | Hysteresis | | | | 100 | | mV |
| WAKE INPUT | | | | | | | | |
| V _{WAKE_ON} | Voltage threshold to enable device | WAKE pin is a level sensitive input | | | 3.3 | 3.7 | V | |
| VBAT UNDERVOLTAGE WARNING | | | | | | | | |
| V _{SSENSETH_L} | V _{SENSE} falling threshold low | SPI selectable, default after reset | | | 4.3 | 4.7 | V | |
| V _{SSENSETH_H} | V _{SENSE} falling threshold high | SPI selectable | | | 6.2 | 6.8 | V | |
| V _{SSENSE-HY} | V _{SENSE} hysteresis | | | | | 0.2 | V | |
| I _{VSLEAK} | Leakage current at V _{SENSE} | LPM0 mode, V _{SENSE} 55 V | | | | 1 | μA | |
| I _{VSLEAK60} | Leakage current at V _{SENSE} | LPM0 mode, V _{SENSE} 60 V | | | | 100 | μA | |
| I _{VSLEAK80} | Leakage current at V _{SENSE} | LPM0 mode, V _{SENSE} 80 V | | | 5 | 25 | mA | |

Electrical Characteristics (continued)

 VIN = VINPROT 4.8 V to 40 V, VSUPx = 3 V to 5.5 V, EXTSUP = 0 V, T_{J(max)} = 150°C, unless otherwise noted

| PARAMETER | | TEST CONDITIONS | MIN | TYP | MAX | UNIT |
|--|---|---|-------|-------|-------|------|
| R _{VSSENSE} | Internal resistance from VSSENSE to GND | VSSENSE = 14 V, disabled in LPM0 mode | 0.7 | 1 | 1.3 | MΩ |
| VIN OVERVOLTAGE PROTECTION | | | | | | |
| V _{OVTH_H} | VIN overvoltage shutdown threshold 1 (rising edge) | Selectable with SPI | 50 | | 60 | V |
| V _{OVTH_L} | VIN overvoltage shutdown threshold 2 (rising edge) | Selectable with SPI, default after reset | 36 | | 38 | V |
| V _{OVHY} | VIN overvoltage hysteresis | Threshold 1 | 0.2 | 1.7 | 3 | V |
| | | Threshold 2 - default after reset | 1.5 | 2 | 2.5 | |
| WINDOW WATCHDOG | | | | | | |
| V _{I_high} | High level input voltage | WD, VIO = 3.3 V | 2 | | | V |
| V _{I_low} | Low level input voltage | WD, VIO = 3.3 V | | | 0.8 | V |
| V _{I_hys} | Input voltage hysteresis | WD, VIO = 3.3 V | 150 | | 500 | mV |
| RESET AND IRQ BLOCK | | | | | | |
| V _{RESL} | Low level output voltage at RESN, PRESN and IRQ | VIN ≥ 3 V, I _{xRESN} = 2.5 mA | 0 | | 0.4 | V |
| V _{RESL} | Low level output voltage at RESN and PRESN | VIN = 0 V, VIO = 1.2 V, I _{xRESN} = 1 mA | 0 | | 0.4 | V |
| I _{RESLeak} | Leakage current at RESN, PRESN and IRQ | V _{rest} = 5.5 V | | | 1 | μA |
| N _{RES} | Number of consecutive reset events for transfer to LPM0 | | | 7 | | |
| EXTERNAL PROTECTION | | | | | | |
| VCLAMP | Gate to source clamp voltage | VIN - GPFET, 100 μA | 14 | | 20 | V |
| IGPFET | Gate turn on current | VIN = 14 V, GPFET = 2 V | 15 | | 25 | μA |
| RDSONGFET | Gate driver strength | VIN = 14 V, turn off | | | 25 | Ω |
| THERMAL SHUTDOWN AND OVERTEMPERATURE PROTECTION | | | | | | |
| T _{SDTH} | Thermal shutdown | Junction temperature | 160 | 175 | | °C |
| T _{SDHY} | Hysteresis | | | 20 | | °C |
| T _{OTTH} | Overtemperature flag | Overtemperature flag is implemented as local temp sensors and expected to trigger before the thermal shutdown | 150 | 165 | | °C |
| T _{OTHY} | Hysteresis | | | 20 | | °C |
| VOLTAGE MONITORS BUCK1/2/3, VIO, LDO, BOOSTER | | | | | | |
| V _{MONTH_L} | Voltage monitor reference | REF = 0.8 V – falling edge | 90% | 92% | 94% | |
| V _{MONTH_H} | Voltage monitor reference | REF = 0.8 V – rising edge | 106% | 108% | 110% | |
| V _{MON_HY} | Voltage monitor hysteresis | | | 2% | | |
| V _{VIOMON_TH} | Undervoltage monitoring at VIO – falling edge | | 3 | | 3.13 | V |
| V _{VIOMON_HY} | UV_VIO hysteresis | | | 0.05 | | V |
| GND LOSS | | | | | | |
| V _{GLTH-low} | GND loss threshold low | GND to PGNDx | -0.31 | -0.25 | -0.19 | V |
| V _{GLTH-high} | GND loss threshold high | GND to PGNDx | 0.19 | 0.25 | 0.31 | V |
| INTERNAL VOLTAGE REGULATORS | | | | | | |
| V _{REG} | Internal regulated supply | I _{VREG} = 0 mA to 50 mA, VINPROT = 6.3 V to 40 V and EXTSUP = 6.3 V to 12 V | 5.5 | 5.8 | 6.1 | V |
| V _{EXTSUP-TH} | Switch over voltage | I _{VREG} = 0 mA to 50 mA and EXTSUP ramping positive, ACTIVE mode | 4.4 | 4.6 | 4.8 | V |
| V _{EXTSUP-HY} | Switch over hysteresis | | 100 | 200 | 300 | mV |
| V _{REGDROP} | Drop out voltage on VREG | I _{VREG} = 50 mA, EXTSUP = 5 V / VINPROT = 5 V and EXTSUP = 0 V / VINPROT = 4 V | | | 200 | mV |
| I _{REG_CL} | Current limit on VREG | EXTSUP = 0 V, VREG = 0 V | -250 | | -50 | mA |
| I _{REG_EXTSUP_CL} | | EXTSUP ≥ 4.8 V, VREG = 0 V | -250 | | -50 | mA |
| C _{VREG} | Capacitive load | | 1.2 | 2.2 | 3.3 | μF |

Electrical Characteristics (continued)

VIN = VINPROT 4.8 V to 40 V, VSUPx = 3 V to 5.5 V, EXTSUP = 0 V, T_{J(max)} = 150°C, unless otherwise noted

| PARAMETER | | TEST CONDITIONS | MIN | TYP | MAX | UNIT |
|--------------------------|--|-------------------------------------|------|------|------|------|
| V _{REG-OK} | VREG undervoltage threshold | VREG rising | 3.8 | 4 | 4.2 | V |
| | | Hysteresis | 350 | 420 | 490 | mV |
| VDVDD | Internal regulated low voltage supply | | 3.15 | 3.3 | 3.45 | V |
| VDVDD UV | DVDD undervoltage threshold | DVDD falling | 2.1 | | | V |
| VDVDD OV | DVDD overvoltage threshold | DVDD rising | | | 3.8 | V |
| SPI | | | | | | |
| V _{I,high} | High level input voltage | CSN, SCK, SDI; VIO = 3.3 V | 2 | | | V |
| V _{I,low} | Low level input voltage | CSN, SCK, SDI; VIO = 3.3 V | | | 0.8 | V |
| V _{I,hys} | Input voltage hysteresis | CSN, SCK, SDI; VIO = 3.3 V | 150 | | 500 | mV |
| V _{O,high} | SDO output high voltage | VIO = 3.3 V I _{SDO} = 1 mA | 3 | | | V |
| V _{O,low} | SDO output low voltage | VIO = 3.3 V I _{SDO} = 1 mA | | | 0.2 | V |
| CSDO | SDO capacitance | | | | 50 | pF |
| GLOBAL PARAMETERS | | | | | | |
| R _{PU} | Internal pullup resistor at CSN pin | | 70 | 100 | 130 | kΩ |
| R _{PD} | Internal pulldown resistor at pins: HSPWM, SDI, SCK, WD, S2 ⁽⁵⁾ | | 70 | 100 | 130 | kΩ |
| R _{PD-WAKE} | Internal pulldown resistor at WAKE pin | | 140 | 200 | 260 | kΩ |
| I _{LKG} | Input pullup current at pins: - VSENSE1–5 - VMON1–3 | V _{TEST} = 0.8 V | –200 | –100 | –50 | nA |

(5) RAMP and ACTIVE only

7.6 Timing Requirements

| | | MIN | TYP | MAX | UNIT | |
|---|---|--|-----|-----|------|----|
| BUCK CONTROLLER (BUCK1) | | | | | | |
| t _{OCBUCK1_BLK} | RSTN and ERROR mode transition, when over current detected for > t _{OCBUCK1_BLK} | | 1 | | ms | |
| LED AND HIGH-SIDE SWITCH CONTROL | | | | | | |
| t _{HSOL_BLK} | Open load blanking time | 70 | 100 | 140 | μs | |
| t _{HSS_CL} | Net time in current limit to disable driver | 4 | 5 | 6 | ms | |
| t _{S_HS} | Current-limit sampling interval | | 100 | | μs | |
| t _{ON} | Turnon time | Time from rising HSPWM till high-side switch in current limitation, ±5% settling | | | 30 | μs |
| | | Time from rising HSPWM till high-side switch till voltage-clamp between HSENSE – HSCTRL active (within V _{GS} limits) | | 30 | 60 | μs |
| f _{HS_IN} | HSPWM input frequency | Design information, no device parameter | 100 | 500 | Hz | |
| REFERENCE VOLTAGE | | | | | | |
| T _{REF_OK} | Reference voltage OK deglitch time | | 10 | 20 | μs | |
| SHUTDOWN COMPARATOR | | | | | | |
| T _{VT_REF_FLT} | VT_REF fault deglitch time | Overvoltage or short condition on VT_REF | 10 | 20 | μs | |
| WAKE INPUT | | | | | | |
| t _{WAKE} | Min. pulse width at WAKE to enable device | V _{WAKE} = 4 V to suppress short spikes at WAKE pin | 10 | 20 | μs | |
| VBAT UNDERVOLTAGE WARNING | | | | | | |
| t _{VSENSE_BLK} | Blanking time | V _{VSENSE} < V _{SSENSETH_xx} → IRQ asserted | 10 | 35 | μs | |
| VIN OVERVOLTAGE PROTECTION | | | | | | |
| t _{OFF_BLK-H} | OV delay time | VIN > V _{OVT_H} → GPFET off | | 1 | μs | |
| t _{OFF_BLK-L} | OV blanking time | VIN > V _{OVT_L} → GPFET off | 10 | 20 | μs | |

Timing Requirements (continued)

| | | MIN | TYP | MAX | UNIT |
|--|--|--|-----|------|-------------------|
| WINDOW WATCHDOG | | | | | |
| t_{timeout} | Timeout | 230 | 300 | 370 | ms |
| t_{WD} | Watchdog window time | Spread spectrum disabled | | 22 | ms |
| | | Spread spectrum enable | | 24.2 | |
| $t_{\text{WD_FAIL}}$ | Closed window time | $t_{\text{WD}} / 4$ | | | |
| $t_{\text{WD_BLK}}$ | WD filter time | | | | 1.2 μs |
| RESET AND IRQ BLOCK | | | | | |
| t_{RESHOLD} | RESN hold time | 1.8 | 2 | 2.2 | ms |
| t_{IRQHOLD} | IRQ hold time | After $V_{\text{VSENSE}} < V_{\text{SSENSETH}}$ for $t_{\text{VSENSE_BLK}}$ | | 20 | μs |
| $t_{\text{DR_IRQ_PRESN}}$ | Rising edge delay of IRQ to rising edge of PRESN | | | | 2 μs |
| $t_{\text{DF_RESN_PRESN}}$ | Falling edge delay of RESN to PRESN / IRQ | | | | 2 μs |
| THERMAL SHUTDOWN AND OVERTEMPERATURE PROTECTION | | | | | |
| $t_{\text{SD_BLK}}$ | Blanking time before thermal shutdown | 10 | | | 20 μs |
| $t_{\text{OT_BLK}}$ | Blanking time before thermal over temperature | 10 | | | 20 μs |
| VOLTAGE MONITORS BUCK1/2/3, VIO, LDO, BOOSTER | | | | | |
| $t_{\text{VMON_BLK}}$ | Blanking time between UV/OV condition to RESN low | UV/OV: BUCK1/2/3 UV: VIO | | 20 | μs |
| $t_{\text{VMONTHL_BLK}}$ | Blanking time between undervoltage condition to ERROR mode transition or corresponding SPI bit | BUCK1/2/3 → ERROR mode LDO or BOOST → SPI bit set or turn off | | 1 | ms |
| $t_{\text{VMONTHL_BLK1}}$ | Blanking time between undervoltage condition to ERROR mode transition | VIO only | | 20 | μs |
| $t_{\text{VMONTHH_BLK1}}$ | Blanking time between overvoltage condition to ERROR mode transition | BUCK1/2/3 → ERROR mode VIO has no OV protection | | 20 | μs |
| $t_{\text{VMONTHH_BLK2}}$ | Blanking time LDO and BOOST overvoltage condition to corresponding SPI bit or ERROR mode | LDO or BOOST (ACTIVE mode) → SPI bit set or turn off LDO (VTCHECK or RAMP mode) → ERROR mode | | 40 | μs |
| GND LOSS | | | | | |
| $t_{\text{GL_BLK}}$ | Blanking time between GND loss condition and transition to ERROR state | 5 | | | 20 μs |
| POWER-UP SEQUENCING | | | | | |
| t_{START1} | Soft start time of BOOST | From start till exceeding $V_{\text{MONTH_L}} + V_{\text{MON_HY}}$ Level | | 2.7 | ms |
| t_{START2} | Soft start time of BUCK1/2/3 and LDO | From start till exceeding $V_{\text{MONTH_L}} + V_{\text{MON_HY}}$ Level | | 2 | ms |
| t_{START} | Startup DVDD regulator | From start till exceeding $V_{\text{MONTH_L}} + V_{\text{MON_HY}}$ Level | | 3 | ms |
| t_{SEQ2} | Sequencing time from start of BUCK1 to BUCK2 and BOOST | Internal SSDONE_BUCK1 signal | | 3 | ms |
| $t_{\text{WAKE-RES}}$ | Startup time from entering TESTSTART to RESN high | GPFET = IRFR6215 | | 14 | ms |
| t_{SEQ1} | Sequencing time from start of BOOST to BUCK3 | Internal SSDONE_BOOST signal | | 4 | ms |
| INTERNAL VOLTAGE REGULATORS | | | | | |
| $t_{\text{DVDD_OV}}$ | Blanking time from DVDD overvoltage condition to shutdown mode transition | 10 | | | 20 μs |
| SPI INTERFACE | | | | | |
| t_{SPI} | SCK period | | | 240 | ns |
| t_{SCKL} | SCK low time | See Figure 1 | | 100 | ns |
| t_{SCKH} | SCK high time | | | 100 | ns |
| t_{FSIV} | Time between falling edge of CSN and SDO output valid (FSI bit) | Falling SDO < 0.8 V; Rising SDO > 2 V, See Figure 1 | | 80 | ns |
| t_{SDOV} | Time between rising edge of SCK and SDO data valid | Falling SDO < 0.8 V; Rising SDO > 2 V, See Figure 1 | | 55 | ns |
| t_{SDIS} | Setup time of SDI before falling edge of SCK | See Figure 1 | | 20 | ns |
| t_{SDOH} | Hold time of SDO after rising edge of SCK | | | 5 | ns |
| t_{HCS} | Hold time of CSN after last falling edge of SCK | | | 50 | ns |
| t_{SDOtri} | Delay between rising edge of CSN and SDO 3-state | See Figure 1 | | 80 | ns |

Timing Requirements (continued)

| | | MIN | TYP | MAX | UNIT |
|-----------------|---------------------------------------|-----|-----|-----|---------|
| $t_{\min 2SPI}$ | Minimum time between two SPI commands | 10 | | | μs |

7.7 Switching Characteristics

over operating free-air temperature range (unless otherwise noted)

| PARAMETER | TEST CONDITIONS | MIN | TYP | MAX | UNIT |
|---|--|---------------------------|----------------|-----------|------|
| BUCK CONTROLLER (BUCK1) | | | | | |
| $f_{SWBUCK1}$ | Switching frequency | | $f_{OSC} / 10$ | | |
| DC | Duty cycle | High-side minimum on time | 100 | | ns |
| | | Maximum duty cycle | 98.75% | | |
| t_{DEAD_BUCK1} | Shoot-through delay, blanking time | | 25 | | ns |
| SYNCHRONOUS BUCK CONVERTER BUCK2/3 | | | | | |
| $f_{SWLBUCK2/3}$ | Buck switching frequency | | $f_{OSC} / 2$ | | |
| DC _{BUCK2/3} | Duty cycle | High-side minimum on time | 50 | | ns |
| | | Maximum duty cycle | 99.8% | | |
| $t_{DEAD_BUCK2/3}$ | Shoot-through delay | | 20 | | ns |
| BOOST CONVERTER | | | | | |
| $f_{SWLBOOST}$ | Boost switching frequency | | $f_{OSC} / 2$ | | |
| DC _{BOOST} | Maximum internal MOSFET duty cycle at $f_{SWLBOOST}$ | | 75% | | |
| GLOBAL PARAMETERS | | | | | |
| f_{OSC} | Internal oscillator used for Buck or Boost switching frequency | 4.6 | 4.9 | 5.2 | MHz |
| f_{spread} | Spread spectrum frequency range | $0.8 \times f_{OSC}$ | | f_{OSC} | |

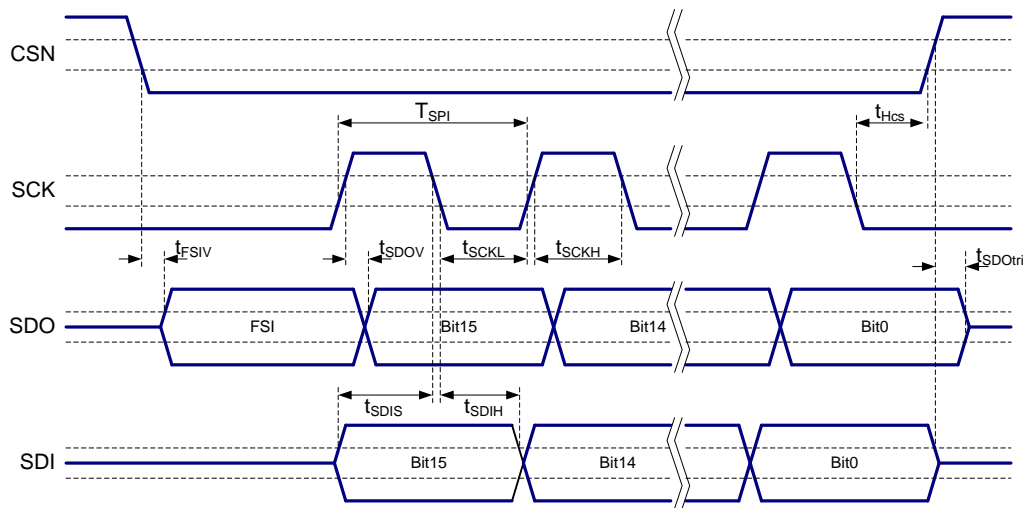

Figure 1. SPI Timing

7.8 Typical Characteristics

All parameters are measured on a TI EVM, unless otherwise specified.

7.8.1 BUCK 1 Characteristics

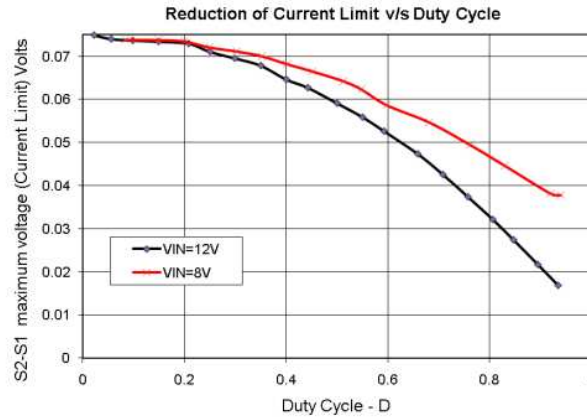

Figure 2. Reduction of Current-Limit vs Duty Cycle

7.8.2 BUCK 2 and BUCK3 Characteristics

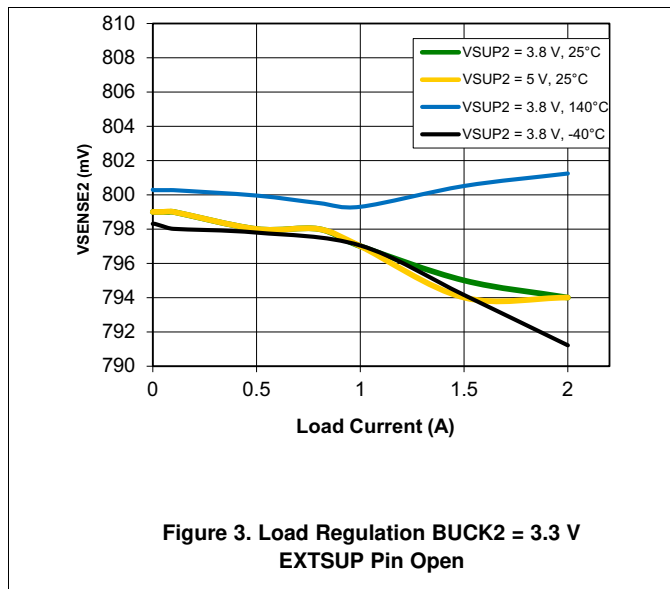

Figure 3. Load Regulation BUCK2 = 3.3 V EXTSUP Pin Open

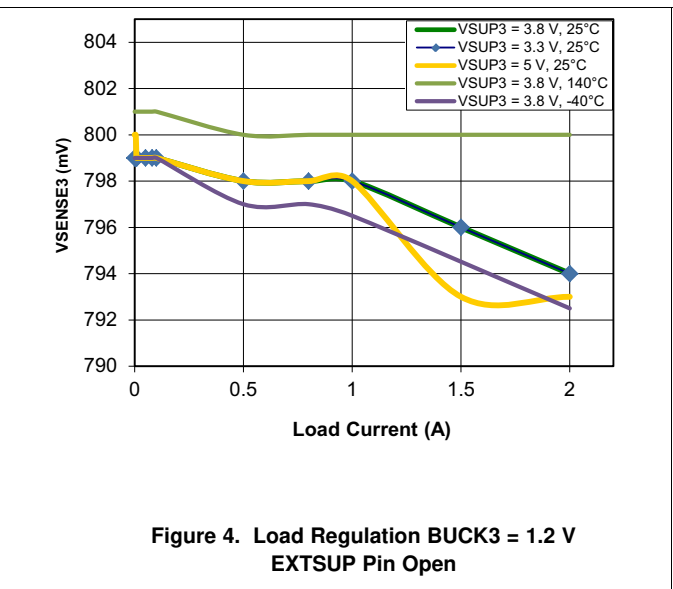

Figure 4. Load Regulation BUCK3 = 1.2 V EXTSUP Pin Open

BUCK 2 and BUCK3 Characteristics (continued)

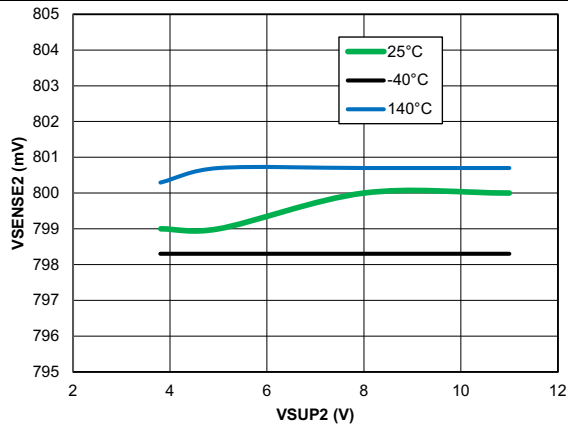

Figure 5. Open-Load Line Regulation BUCK2 = 3.3 V
EXTSUP Pin Open

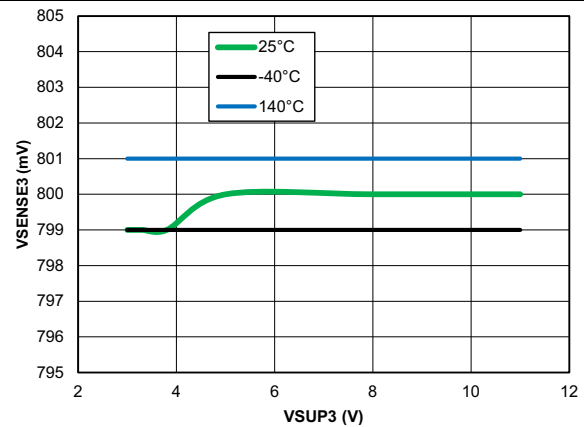

Figure 6. Open-Load Line Regulation BUCK3 = 1.2 V
EXTSUP Pin Open

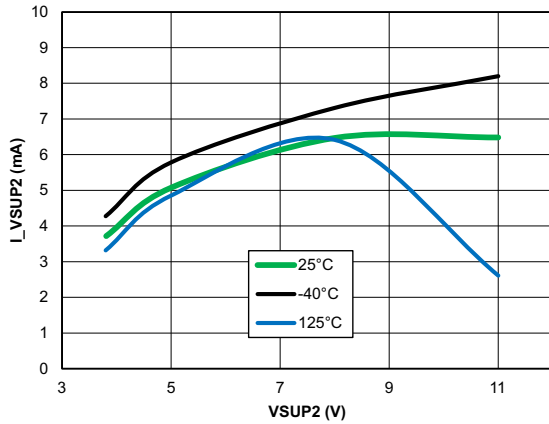

Figure 7. Open-Load Supply Current BUCK2 = 3.3 V
EXTSUP Pin Open

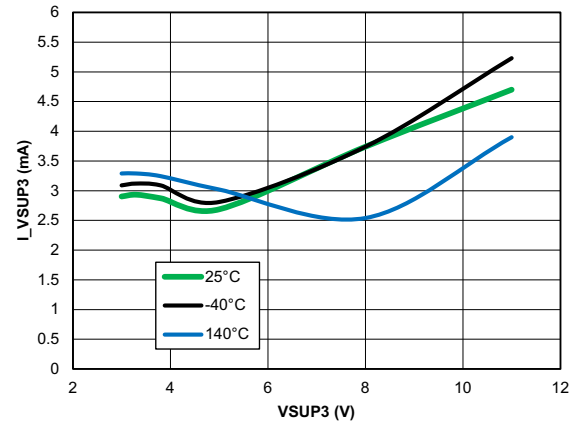

Figure 8. Open-Load Supply Current BUCK3 = 1.2 V
EXTSUP Pin Open

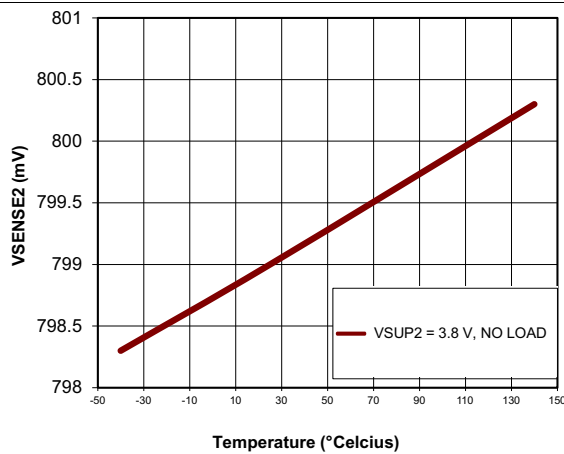

Figure 9. BUCK2 = 3.3-V VSENSE2 vs Temperature
EXTSUP Pin Open

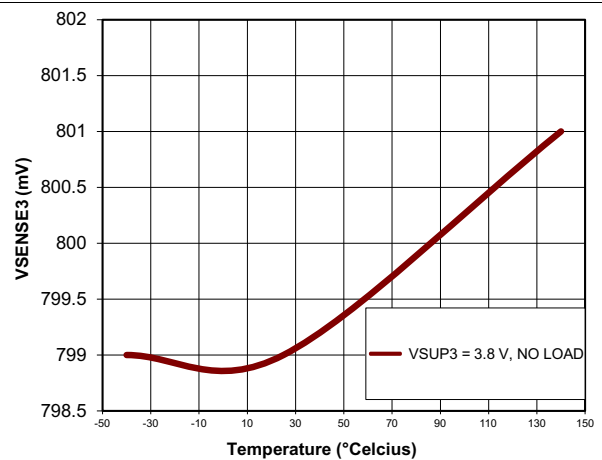
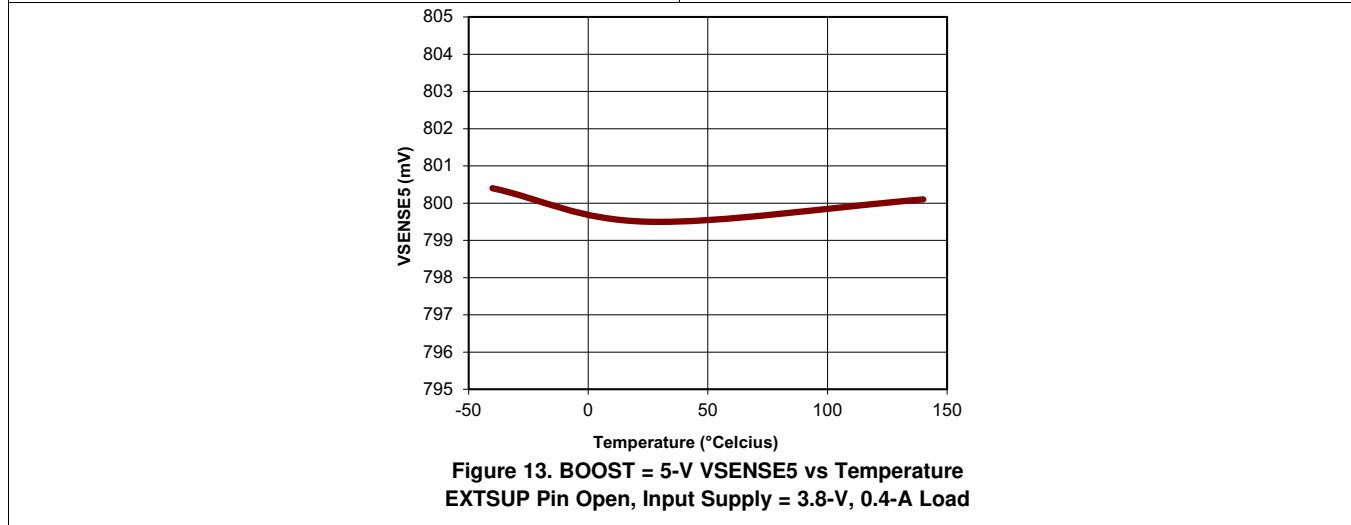
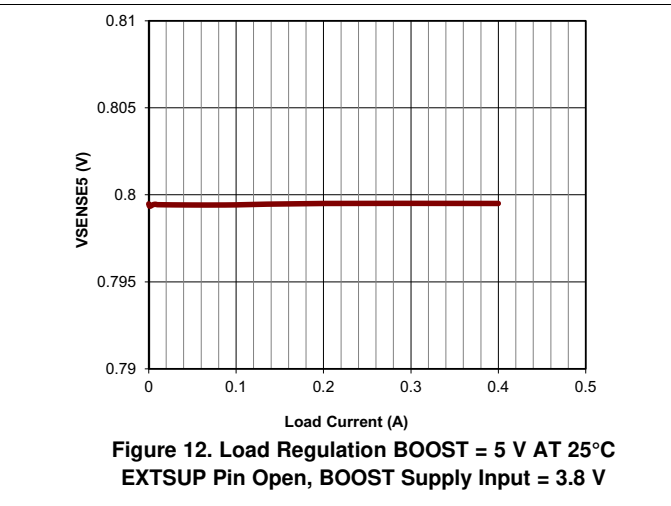
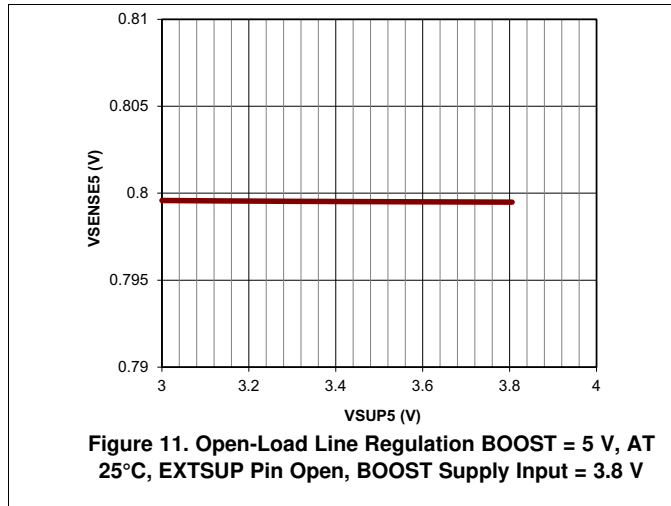

Figure 10. BUCK3 = 1.2-V VSENSE3 vs Temperature
EXTSUP Pin Open

7.8.3 BOOST Characteristics



7.8.4 LDO Noise Characteristics

(2 × 3.3-μF output capacitance, LDO output = 2.5 V, VSUP4 = 3.8 V)

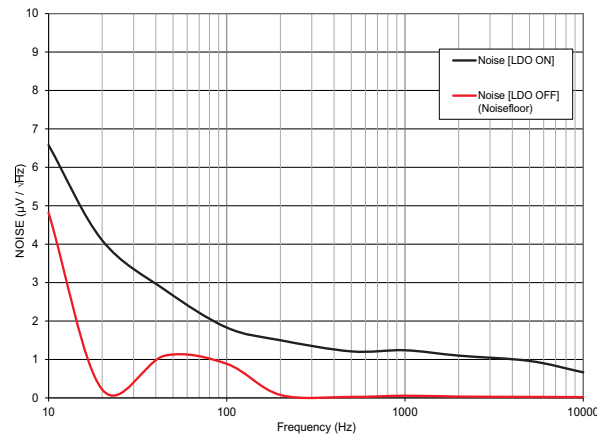

Figure 14. LDO Noise Density

8 Detailed Description

8.1 Overview

The device includes one high-voltage buck controller for pre-regulation combined with a two-buck and one-boost converter for post regulation. A further integrated low-dropout (LDO) regulator rounds up the power-supply concept and offers a flexible system design with five independent-voltage rails. The device offers a low power state (LPM0 with all rails off) to reduce current consumption in case the system is constantly connected to the battery line. All outputs are protected against overload and over temperature.

An external PMOS protection feature makes the device capable of sustaining voltage transients up to 80 V. This external PMOS is also used in safety-critical applications to protect the system in case one of the rails shows a malfunction (undervoltage, overvoltage, or overcurrent).

Internal soft-start ensures controlled startup for all supplies. Each power-supply output has an adjustable output voltage based on the external resistor-network settings.

8.2 Functional Block Diagram

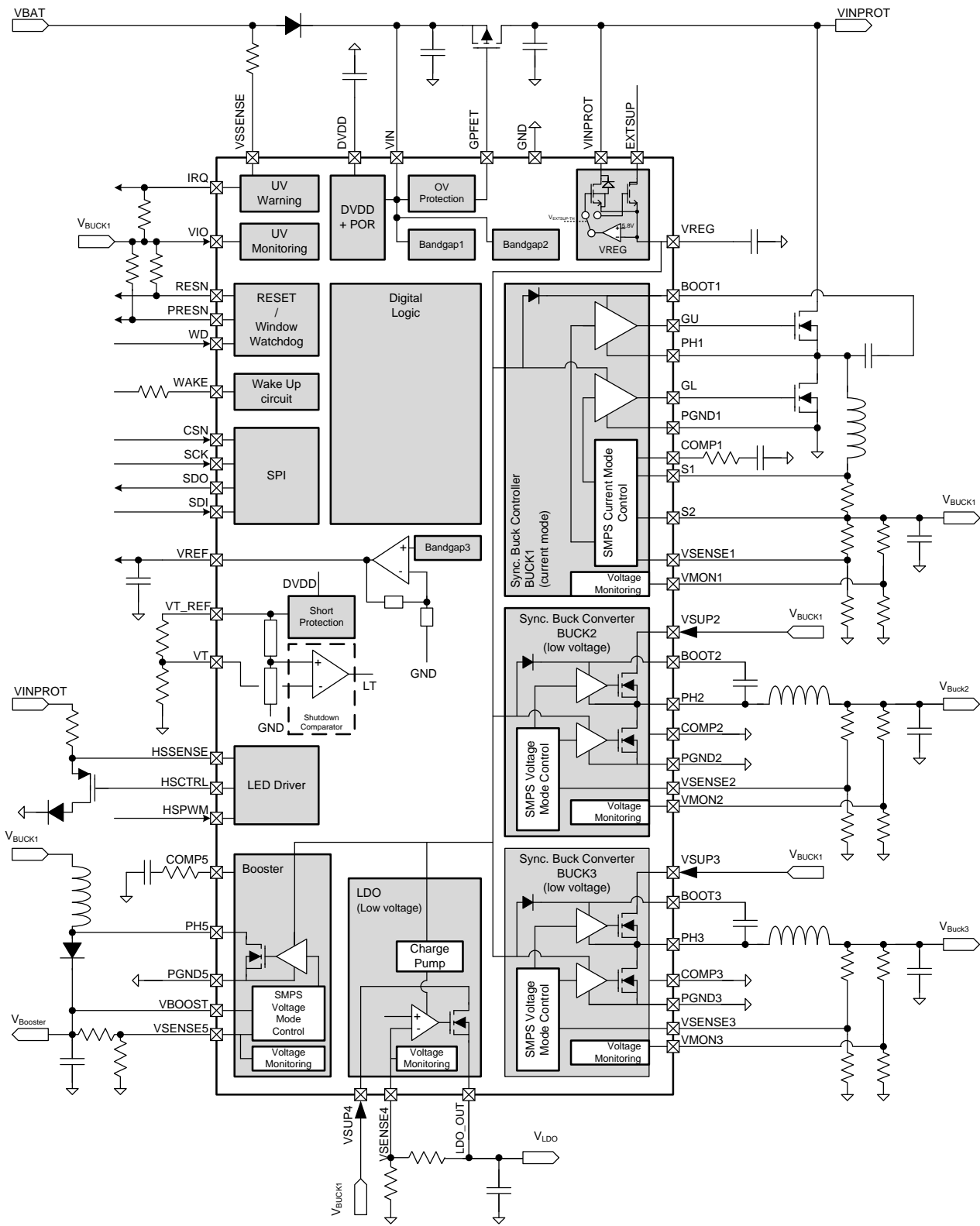

Copyright © 2017, Texas Instruments Incorporated

Figure 15. Detailed Block Diagram

Feature Description (continued)

8.3.2 Synchronous Buck Converters BUCK2 and BUCK3

Both regulators are synchronous converters operating with a fixed switching frequency $f_{sw} = 2.45$ MHz. For each buck converter, the output voltage is programmable with external resistors. The synchronous operation mode improves the overall efficiency. BUCK3 switches in phase with BUCK1, and BUCK2 switches at a 216-degree shift to BUCK3 to minimize input current ripple.

Each buck converter can provide a maximum current of 2 A and is protected against short circuits to ground. In case of a short circuit to ground, the integrated cycle-by-cycle current limit turns off the high-side FET when its current reaches $I_{HS-Limit}$ and the low-side FET is turned on until the end of the given cycle. When the current limit is reached in the beginning of the cycle for five consecutive cycles, the pulse-width modulation (PWM) is forced low for sixteen cycles to prevent uncontrolled current build-up. In case the low-side current limit of $I_{LS-Limit}$ is reached, for example, because of an output short to the VSUP2 and VSUP23 pins, the low-side FET is turned off until the end of the cycle. If this is detected shortly after the high-low PWM transition (immediately after the low-side overcurrent comparator blanking time), both FETs are turned off for sixteen cycles.

The output voltages of the BUCK2 and BUCK3 regulators are monitored by a central independent voltage-monitoring circuit, which has an independent voltage-monitoring bandgap reference for safety reasons. In addition BUCK2 and BUCK3 are thermally protected with a dedicated temperature sensor.

8.3.3 BOOST Converter

The BOOST converter is an asynchronous converter operating with a fixed switching frequency $f_{sw} = 2.45$ MHz. It switches in phase with BUCK1. At low load, the boost regulator switches to pulse skipping.

The output voltage is programmable with external resistors.

The internal low-side switch can handle maximum 1-A current, and is protected with a current limit. In case of an overcurrent, the integrated cycle-by-cycle current limit turns off the low-side FET when its current reaches $I_{CLBOOST}$ until the end of the given cycle. When the current limit is reached in the beginning of the cycle for five consecutive cycles, the PWM is forced low for sixteen cycles to prevent uncontrolled current build-up.

The BOOST converter output voltage is monitored by a central independent voltage-monitoring circuit, which has an independent voltage-monitoring bandgap reference for safety reasons. If the $V_{MONTH_L} > V_{SENSE5}$ or $V_{SENSE5} > V_{MONTH_H}$, the output is switched off and the BOOST_FAIL bit in the SPI PWR_STAT register is set. The BOOST can be reactivated by setting BOOST_EN bit in the PWR_CONFIG register.

In addition, the BOOST converter is thermally protected with a dedicated temperature sensor. If $T_J > T_{OTTH}$, the BOOST converter is switched off and bit OT_BOOST in PWR_STAT register is set. Reactivation of the booster is only possible if the OT_BOOST bit is 0, and the booster enable bit in the PWR_CONFIG register is set to 1.

8.3.4 Frequency-Hopping Spread Spectrum

The TPS65311-Q1 features a frequency-hopping pseudo-random spectrum or triangular spreading architecture. The pseudo-random implementation uses a linear feedback shift register that changes the frequency of the internal oscillator based on a digital code. The shift register is designed in such a way that the frequency shifts only by one step at each cycle to avoid large jumps in the buck and boost switching frequencies. The triangular function uses an up-down counter. Whenever spread spectrum is enabled (SPI command), the internal oscillator frequency is varied from one BUCK1 cycle to the next within a band of $0.8 \times f_{OSC} \dots f_{OSC}$ from a total of 16 different frequencies. This means that BUCK3 and BOOST also step through 16 frequencies. The internal oscillator can also change its frequency during the period of BUCK2, yielding a total of 31 frequencies for BUCK2.

8.3.5 Linear Regulator LDO

The LDO is a low drop out regulator with an adjustable output voltage through an external resistive divider network. The output has an internal current-limit protection in case of an output overload or short circuit to ground. In addition, the output is protected against overtemperature. If $T_J > T_{OTTH}$, the LDO is switched off and bit OT_LDO in PWR_STAT register is set. Reactivation of the LDO is only possible through the SPI by setting the LDO enable bit in the PWR_CONFIG register to 1 if the OT_LDO bit is 0.

Feature Description (continued)

The LDO output voltage is monitored by a central independent voltage-monitoring circuit, which has an independent voltage-monitoring bandgap reference for safety reasons. If the $V_{MONTH_L} > V_{SENSE4}$ or $V_{SENSE4} > V_{MONTH_H}$, the output is switched off and the LDO_FAIL bit in the SPI PWR_STAT register is set. The LDO can be reactivated through the SPI by setting the LDO_EN bit in the PWR_CONFIG register. In case of overvoltage in VTCHECK and RAMP mode, the GPFET is turned off and the device changes to ERROR mode.

8.3.6 Gate Driver Supply

The gate drivers of the BUCK1 controller, BUCK2 and BUCK3 converters and the BOOST converter are supplied from an internal linear regulator. The internal linear regulator output (5.8-V typical) is available at the VREG pin and must be decoupled using a typical 2.2- μ F ceramic capacitor. This pin has an internal current-limit protection and must not be used to power any other circuits.

The VREG linear regulator is powered from VINPROT by default when the EXTSUP voltage is less than 4.6 V (typical).

If the VINPROT is expected to go to high levels, there can be excessive power dissipation in this regulator when using large external MOSFETs. In this case, it is advantageous to power this regulator from the EXTSUP pin, which can be connected to a supply less than VINPROT but high enough to provide the gate drive. When EXTSUP is connected to a voltage greater than 4.8 V, the linear regulator automatically switches to EXTSUP as its input to provide this advantage. This automatic switch-over to EXTSUP can only happen once the TPS65311-Q1 device reaches ACTIVE mode. Efficiency improvements are possible when one of the switching regulator rails from the TPS65311-Q1, or any other voltage available in the system is used to power EXTSUP. The maximum voltage that must be applied to EXTSUP is 12 V.

8.3.7 RESET

RESN and PRESN are open drain outputs which are active if one or more of the conditions listed in Table 1 are valid. RESN active (low) is extended for $t_{RESNHOLD}$ after a reset is triggered. RESN is the main processor reset and also asserts PRESN as a slave signal.

PRESN is latched and is released when window trigger mode of the watchdog is enabled (first rising edge at the WD pin).

RESN and PRESN must keep the main processor and peripheral devices in a defined state during power up and power down in case of improper supply voltages or a critical failure condition. Therefore, for low supply voltages the topology of the reset outputs specify that RESN and PRESN are always held at a low level when RESN and PRESN are asserted, even if V_{IN} falls below V_{POR} or the device is in SHUTDOWN mode.

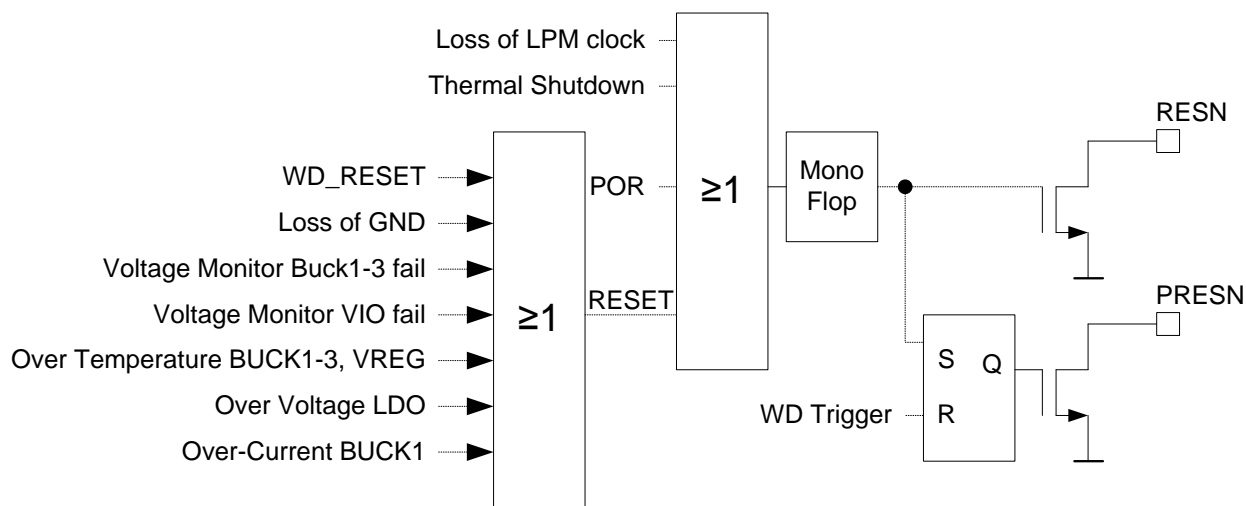

Figure 17. RESET Functionality

Feature Description (continued)

Table 1. Reset Conditions

| RESET CONDITION | CONSEQUENCE FOR DEVICE |
|--|--|
| POR, Loss of LPM Clock, and Thermal Shutdown | The device reinitializes all registers with their default values. Error counter is cleared. |
| Voltage Monitor BUCK 1-3 | Input voltage at V_{MON1-3} pin out-of-bounds: $V_{VMON1-3} < V_{MONTH_L}$ or $V_{VMON1-3} > V_{MONTH_H}$ |
| Over Voltage LDO | $V_{sense4} > V_{MONTH_H}$ |
| Voltage Monitor VIO | Input voltage at VIO pin out-of-bounds: $V_{VIO} < V_{VIOMON_TH}$ |
| Loss of GND | Open at PGNDx or GND pin |
| OT BUCK1, BUCK2, BUCK3, VREG | Overtemperature on BUCK1–3 or VREG |
| WD_RESET | Watchdog window violation |

Any reset event (without POR, thermal shutdown, or loss of LPM clock) increments the error counter (EC) by one. After a reset is consecutively triggered N_{RES} times, the device transfers to the LPM0 state, and the EC is reset to 0. The counter is decremented by one if an SPI LPM0_CMD is received. Alternatively, the device can be put in LOCK state once an SPI LOCK_CMD is received. Once the device is locked, it cannot be activated again by a wake condition. The reset counter and lock function avoid cyclic start-up and shut-down of the device in case of a persistent fault condition. The reset counter content is cleared with a POR condition, a thermal shutdown or a loss of LPM clock. Once the device is locked, a voltage below V_{POR} at VIN pin or a thermal shutdown condition are the only ways to unlock the device.

8.3.8 Soft Start

The output voltage slopes of BUCK, BOOST and LDO regulators are limited during ramp-up (defined by t_{STARTX}). During this period the target output voltage slowly settles to its final value, starting from 0 V. In consequence, regulators that offer low-side transistors (BUCK1, BUCK2 and BUCK3) actively discharge their output rails to the momentary ramp-value if previously charged to a higher value.

8.3.9 Power-on Reset Flag

The POR flag in the SYS_STAT SPI register is set:

- When V_{IN} is below the V_{POR} threshold
- System is in thermal shutdown
- Over or undervoltage on DVDD
- Loss of low power clock

8.3.10 WAKE Pin

Only when the device is in LPM0 mode, it can be activated by a positive voltage on the WAKE pin with a minimum pulse width t_{WAKE} . A valid wake condition is latched. Normal deactivation of the device can only occur through the SPI Interface by sending an SPI command to enter LMP0. Once in LMP0, the device stays in LPM0 when the WAKE pin is low, or restarts to TESTSTART when the WAKE pin is high.

The WAKE pin has an internal pulldown resistance $R_{PD-WAKE}$, and the voltage on the pin is not allowed to exceed 60 V. A higher voltage compliance level in the application can be achieved by applying an external series resistor between the WAKE pin and the external wake-up signal.

The device cannot be re-enabled by toggling the WAKE pin when the device is in LOCKED state (by SPI command).

8.3.11 IRQ Pin

The IRQ pin has two different functions. In OPERATING mode, the pin is forced low when the voltage on the battery line is below the $V_{SSENSETHX}$ threshold. The IRQ pin is low as long as PRESN is low. If PRESN goes high and the battery line is already below the $V_{SSENSETHX}$ threshold, the IRQ pin is forced high for $t_{VSSENSE_BLK}$.

8.3.12 VBAT Undervoltage Warning

- Low battery condition on VSSENSE asserts IRQ output (interrupt for μC , open drain output)
- Sense input can be directly connected to VBAT through the resistor
- Detection threshold for undervoltage warning can be selected through the SPI.
- An integrated filter time avoids false reaction due to spikes on the VBAT line.

8.3.13 VIN Over or Undervoltage Protection

- Undervoltage is monitored on the V_{IN} line, for POR generation.
- Two V_{IN} overvoltage shutdown thresholds (V_{OVRTH}) can be selected through the SPI. After POR, the lower threshold is enabled.
- During LPM0, only the POR condition is monitored.
- An integrated filter time avoids false reaction due to spikes on the V_{IN} line.
- In case of overvoltage, the external PMOS is switched off to protect the device. The BUCK1 controller is not switched off and it continues to run until the undervoltage on VREG or BUCK1 output is detected.

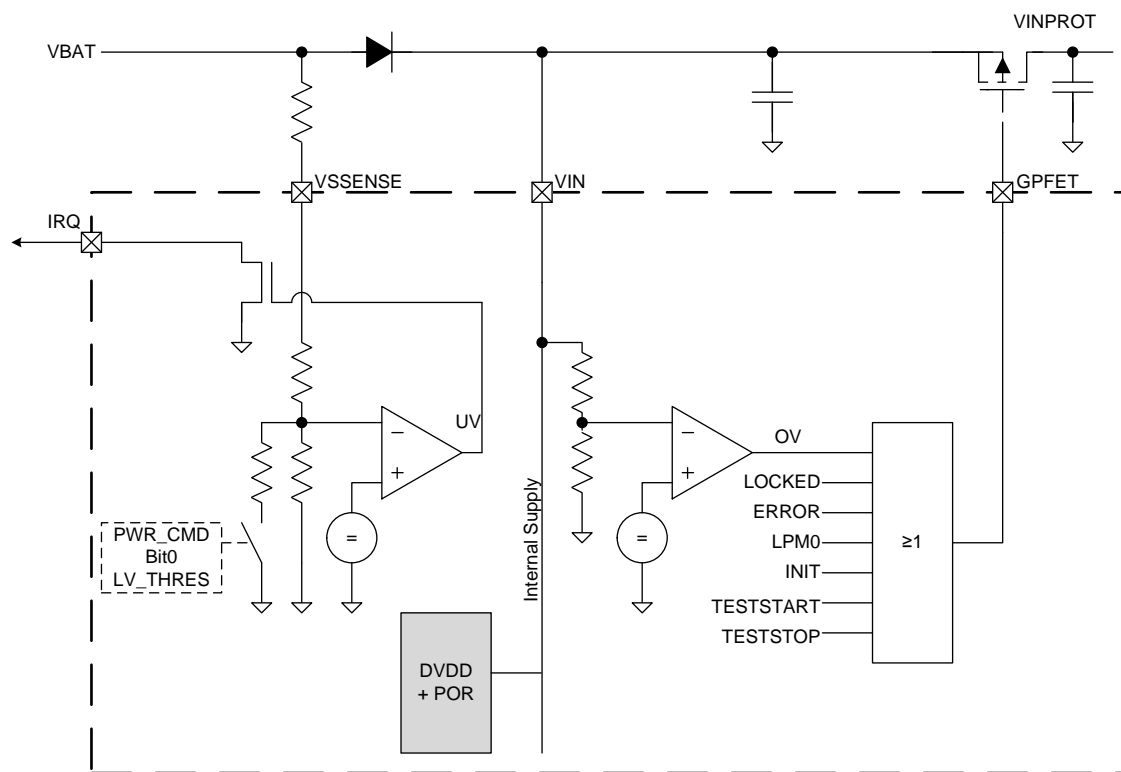

Figure 19. Overage or Undervoltage Detection Circuitry

8.3.14 External Protection

The external PMOS switch is disabled if:

- The device detects V_{IN} overvoltage
- The device is in ERROR, LOCKED, POR, INIT, TESTSTART, TESTSTOP or LPM0 mode

NOTE

Depending on the application, the external PMOS may be omitted as long as $V_{BAT} < 40\text{ V}$

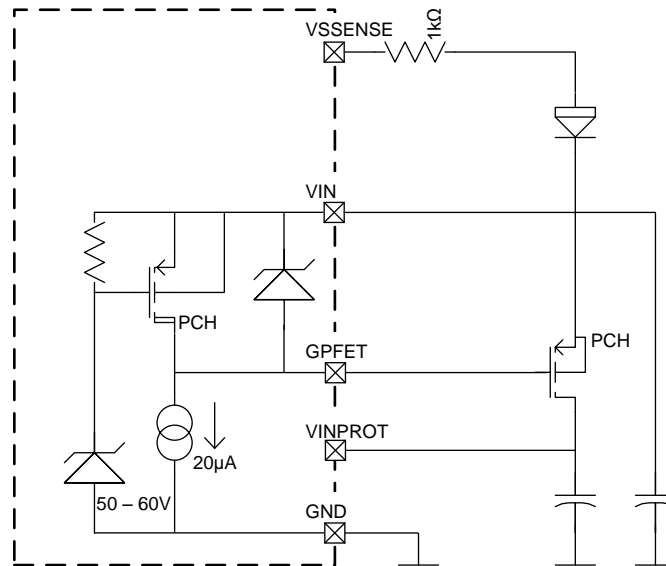

Figure 20. PMOS Control Circuitry

8.3.15 Overtemperature Detection and Shutdown

There are two levels of thermal protection for the device.

Overtemperature is monitored locally on each regulator.

OT for BUCK1, BUCK2, and BUCK3 If a thermal monitor on the buck rails reaches a threshold higher than T_{OTTH} , the device enters ERROR mode. Leaving ERROR mode is only possible if the temperature is below $T_{OTTH} - T_{OTHY}$.

OT for BOOST and LDO If the temperature monitor of the boost or the LDO reaches the T_{OTTH} threshold, the corresponding regulator is switched off.

Overtemperature Shutdown is monitored on a central die position. In case the T_{SDTH} is reached, the device enters shutdown mode. It leaves shutdown when the TSD sensor is below $T_{SDTH} - T_{SDHY}$. This event internally generates a POR.

8.3.16 Independent Voltage Monitoring

The device contains independent voltage-monitoring circuits for BUCK1–3, LDO, VIO and BOOST. The reference voltage for the voltage monitoring unit is derived from an independent bandgap. BUCKs 1–3 use separate input pins for monitoring. The monitoring circuit is implemented as a window comparator with an upper and lower threshold.

If there is a violation of the upper (only LDO [RAMP, VTCHECK], or BUCK1–3) or lower threshold (only BUCK1–3, or VIO), the device enters ERROR mode, RESN and PRESN are asserted low, the external PMOS (main system switch) is switched off, and the EC is incremented.

In TESTSTART mode, a self-test of the independent voltage monitors is performed.

In case any of the supply rails for BUCK2, BUCK3, LDO or BOOST are not used in the application, the respective VMON2 and VMON3 or VSENSE4 and VSENSE5 pin of the unused supply must be connected to VMON1. Alternatively, the VSENSE4 pin can also be connected directly to ground in case the LDO is not used.

8.3.17 GND Loss Detection

All power grounds PGNDx are monitored. If the voltage difference to GND exceeds $V_{GLTH-low}$ or $V_{GLTH-high}$, the device enters ERROR mode. RESN and PRESN are asserted low, the external PMOS (main system switch) is switched off, and the EC is incremented.

8.3.18 Reference Voltage

The device includes a precise voltage reference output to supply a system ADC. If this reference voltage is used in the application, a decoupling capacitor between 0.6 and 5 μ F must be used. If this reference voltage is not used in the application, this decoupling capacitor can be left out. The VREF output is enabled in RAMP state. The output is protected against a short to GND.

8.3.19 Shutdown Comparator

An auxiliary, short circuit protected output supplied from DVDD is provided at the VT_REF pin. This output is used as a reference for an external resistive divider to the VT pin. In case a voltage $> VT_{TH}$ is detected on the VT pin, the main switch (external PMOS driven by GPFET) is switched off. This functionality can be used to monitor over and under temperature (using a NTC resistor) to avoid operation below or above device specifications.

If the voltage at VT_REF falls below $V_{VT_REF_SH}$ while the shutdown comparator is enabled, an ERROR transition occurs. The shutdown comparator is enabled in VTCHECK state, and can be turned off by SPI. Disabling the comparator saves power by also disabling the VT_REF output.

8.3.20 LED and High-Side Switch Control

This module controls an external PMOS in current-limited high-side switch.

The current levels can be adjusted with an external sense resistor. Enable and disable is done with the HS_EN bit. The switch is controlled by the HSPWM input pin. Driving HSPWM high turns on the external FET.

The device offers an open load diagnostic indicated by the HS_OL flag in the SPI register PWR_STAT. Open load is also indicated in case the voltage on VINPROT–VSENSE does not drop below the threshold when PWM is low (self-test).

A counter monitors the overcurrent condition to detect the risk of overheating. While HSPWM = high and HS_EN = high the counter is incremented during overcurrent conditions, and decremented if the current is below the overcurrent threshold at a sampling interval of t_{S_HS} (see Figure 22). When reaching a net current limit time of t_{HSS_CL} , the driver is turned off and the HS_EN bit is cleared. This feature can be disabled by SPI bit HS_CLDIS. When HS_EN is cleared, the counter is reset.

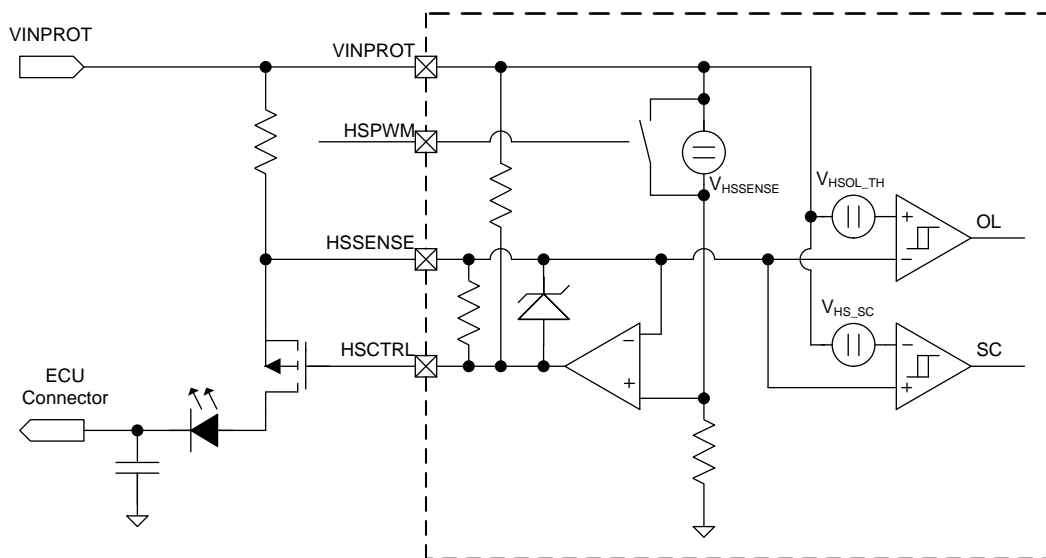

Figure 21. High-Side Control Circuit

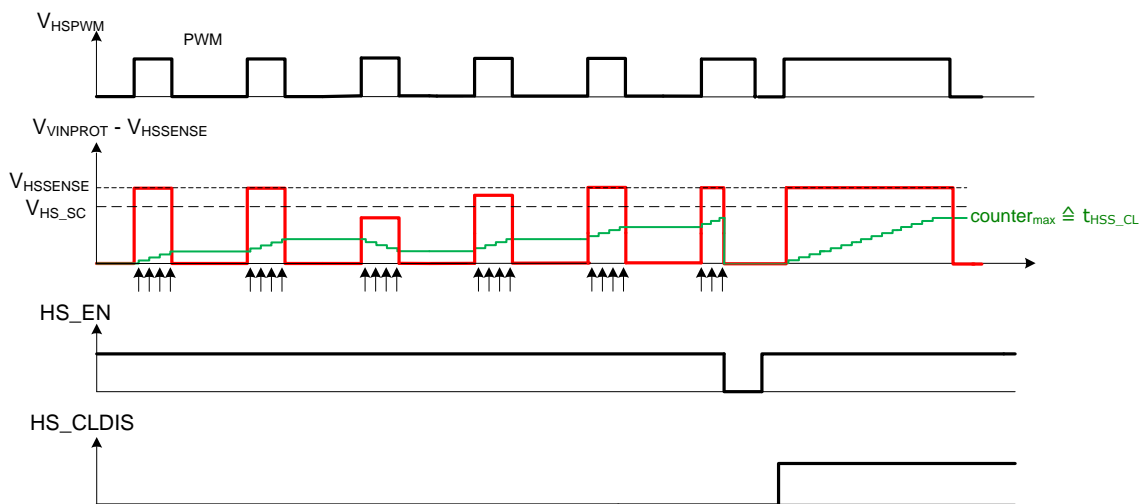

Figure 22. HS Overcurrent Counter

NOTE

In case the LED or high-side switch control is not used in the application, HSENSE must be connected to VINPROT.

8.3.21 Window Watchdog

The WD is used to detect a malfunction of the MCU and DSP. Description:

- Timeout trigger mode with long timing starts on the rising edge at RESN
- Window trigger mode with fixed timing after the first and each subsequent rising edge at the WD pin
- Watchdog is triggered by rising edge at the WD pin

A watchdog reset happens by:

- A trigger pulse outside the WD trigger open window
- No trigger pulse during window time

After the RESN pin is released (rising edge) the DSP and MCU must trigger the WD by a rising edge on the WD pin within a fixed time t_{timeout} . With this first trigger, the window watchdog functionality is released.

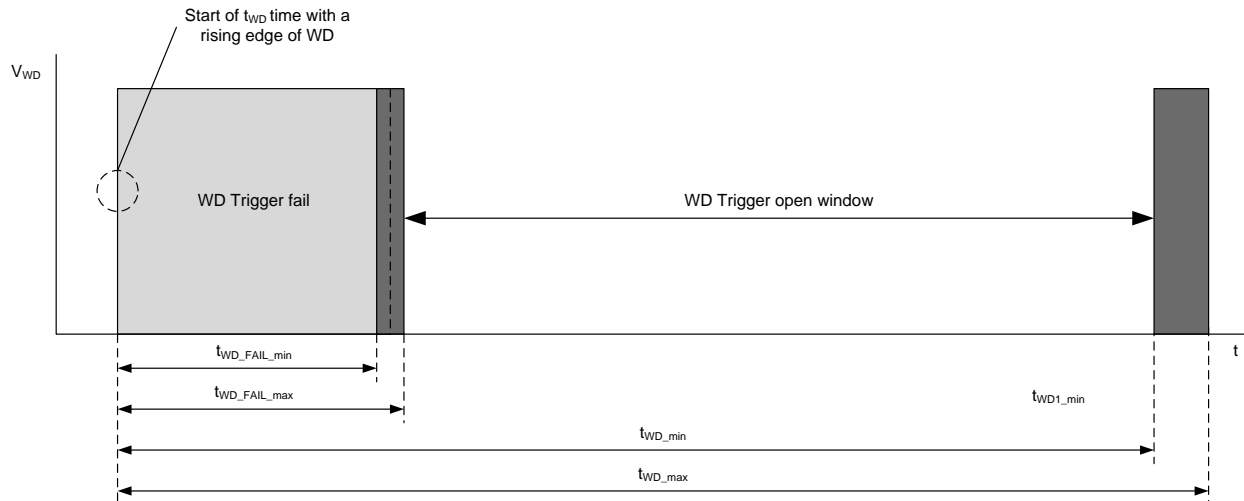

Figure 23. WD Window Description

8.3.22 Timeout in Start-Up Modes

A timer is used to limit the time during which the device can stay in each of the start-up modes: TESTSTART, TESTSTOP, VTCHECK and RAMP. If the device enters one of these start-up modes and V_{IN} or V_T is not in a proper range, the part enters LPM0 after t_{timeout} is elapsed and the WAKE pin is low.

8.4 Device Functional Modes

8.4.1 Operating Modes

8.4.1.1 INIT

Coming from a power-on reset the device enters INIT mode. The configuration data from the EEPROM is loaded in this mode. If the checksum is valid and the internal VREG monitor is indicating an undervoltage condition (self-test VREG comparator), the device enters TESTSTART.

8.4.1.2 TESTSTART

TESTSTART mode is entered:

- After the INIT state (coming from power on)
- After detecting that $V_T > V_{T_{TH-H}}$
- After ERROR mode and the fail condition is gone
- After a wake command in LPM0

In this mode the OV and UV comparators of BUCK1, BUCK2, BUCK3, BOOST, LDO and VIO are tested. The test is implemented in such a way that during this mode all comparators have to deliver a 1 (fail condition). If this is the case the device enters TESTSTOP mode.

If this is not the case, the device stays in TESTSTART. If the WAKE pin is low, the device enters LPM0 after t_{timeout} . If the pin WAKE is high, the part stays in TESTSTART.

8.4.1.3 TESTSTOP

In this mode the OV and UV comparators are switched to normal operation. It is expected that only the UV comparators give a fail signal. In case there is an OV condition on any rail or one of the rails has an overtemperature the device stays in TESTSTOP. If the WAKE pin is low the device enters LPM0 mode after t_{timeout} . If the WAKE pin is high, the part stays in TESTSTOP. If there is no overvoltage and overtemperature detected, the part enters VTCHECK mode.

Device Functional Modes (continued)

8.4.1.4 VTCHECK

VTCHECK mode is used to:

1. Switch on external GPFET in case $V_{IN} < V_{OVTH_L}$
2. Turn on VREG regulator and VT_REF
3. Check if voltage on pin VT $< V_{T_{TH-L}}$
4. Check if SMPS clock is running correctly
5. Check if VREG, VT_REF exceed the minimum voltage

If all checks are valid the part enters the RAMP state. In case the device is indicating a malfunction and the WAKE pin is low, the device enters LPM0 after $t_{timeout}$ to reduce current consumption.

In case the voltage monitors detect an overvoltage condition on BUCK1, BUCK2, BUCK3, or LDO, a loss of GND or an overtemperature condition on BUCK1, BUCK2, BUCK3, or VREG the device enters ERROR mode and the error counter is increased.

8.4.1.5 RAMP

In this mode the device runs through the power-up sequencing of the SMPS rails (see [Figure 24](#)).

8.4.1.5.1 Power-Up Sequencing

After the power-up sequence (see [Figure 24](#)), all blocks are fully functional. BUCK1 starts first. After t_{SEQ2} elapses and BUCK1 is above the undervoltage threshold, BUCK2 and BOOST start. BUCK3 and VREF start one t_{SEQ1} after BUCK2. After the release of RESN pin, the μC can enable the LDO per SPI by setting bit 4 LDO_EN in PWR_CONFIG register to 1 (per default, this LDO_EN is set to 0 after each reset to the μC).

In case any of the following conditions occur during power-up sequencing, the device enters ERROR mode and the error counter (EC) is increased:

- Overtemperature on BUCK1, BUCK2, BUCK3 or VREG
- Overvoltage on BUCK1, BUCK2, BUCK3 or LDO
- Overcurrent on BUCK1
- SMPS clock fail
- VT_REF and VREG undervoltage
- Loss of GND

In case $V_T > V_{T_{TH-H}}$, the device transitions to TESTSTART.

Device Functional Modes (continued)

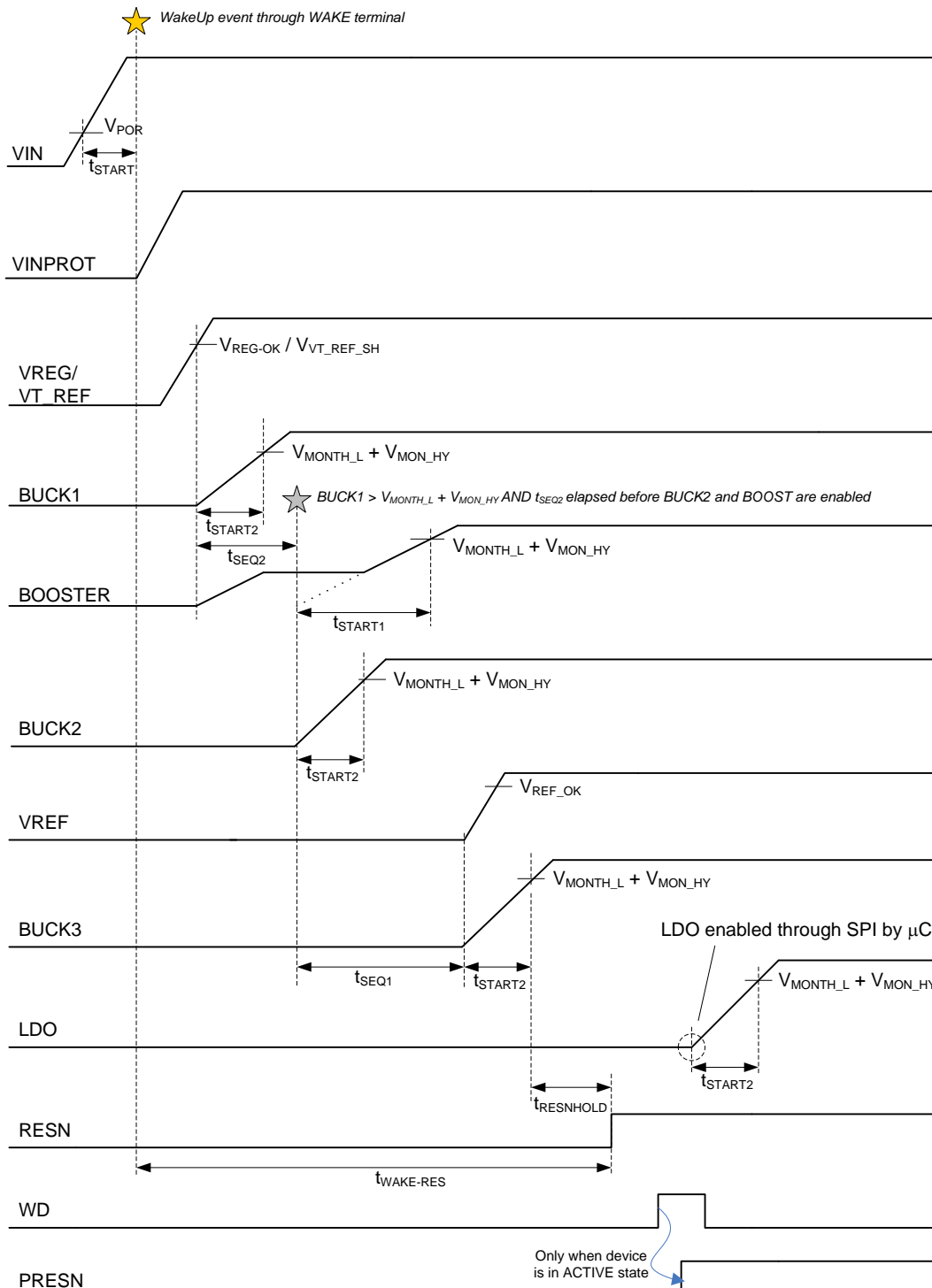

★ In case of permanent supply with the device in LPM0 mode, the start point of VREG-VT_REF is with the rising edge of WAKE. In case of non-permanent supply, the rising edge of the VSSENSE and VIN terminals initiates the start-up sequence

Figure 24. Power-up Sequencing

Device Functional Modes (continued)

After the power-up sequence is completed (except LDO) without detecting an error condition, the device enters ACTIVE mode.

8.4.1.5.2 Power-Down Sequencing

There is no dedicated power-down sequencing. All rails are switched off at the same time. The external FETs of BUCK1 are switched off and the outputs of BUCK2, BUCK3, BOOST (PHx) and the LDO are switched in a high-impedance state.

8.4.1.6 ACTIVE

This is the normal operating mode of the device. Transitions to other modes:

→ ERROR

The device is forced to go to ERROR in case of:

- Any RESET event (without watchdog reset)
- VREG, VREF, or VT_REF below undervoltage threshold
- SMPS clock fail

During the transition to ERROR mode the EC is incremented.

→ LOCKED

In case a dedicated SPI command (SPI_LOCK_CMD) is issued.

→ TESTSTART

The device moves to TESTSTART after detecting that $VT < VT_{TH-L}$.

→ LPM0

The device can be forced to enter LPM0 with a SPI LPM0 command. During this transition the EC is decremented.

If the EC reaches the N_{RES} value, the device transitions to LPM0 mode and EC is cleared. Depending on the state of the WAKE pin, the device remains in LPM0 (WAKE pin low) or restart to TESTSTART (WAKE pin high). To indicate the device entered LPM0 after EC reached N_{RES} value, a status bit EC_OF (error counter overflow, SYS_STAT bit 3) is set. The EC_OF bit is cleared on read access to the SYS_STAT register.

A watchdog reset in ACTIVE mode only increases the EC, but it does not change the device mode.

8.4.1.7 ERROR

In this mode all power stages and the GPFET are switched off. The devices leave ERROR mode and enter TESTSTART if:

- All rails indicate an undervoltage condition
- No GND loss is detected
- No overtemperature condition is detected

When the EC reaches the N_{RES} value, the device transitions to LPM0 and the EC is cleared. To indicate the device entered LPM0 after EC reached N_{RES} , a status bit EC_OF (error counter overflow, SYS_STAT bit 3) is set. The EC_OF bit is cleared on read access to the SYS_STAT register.

8.4.1.8 LOCKED

Entering this mode disables the device. The only way to leave this mode is through a power-on reset, thermal shutdown, or the loss of an LPM clock.

8.4.1.9 LPM0

Low-power mode 0 is used to reduce the quiescent current of the system when no functionality is needed. In this mode the GPFET and all power rails except for DVDD are switched off.

Device Functional Modes (continued)

In case a voltage $> V_{WAKE_ON}$ longer than t_{WAKE} is detected on the WAKE pin, the part switches to TESTSTART mode.

8.4.1.10 SHUTDOWN

The device enters and stays in this mode, as long as $T_J > T_{SDTH} - T_{SDHY}$ or $V_{IN} < V_{POR}$ or DVDD under or overvoltage, or loss of low power clock is detected. Leaving this mode and entering INIT mode generates an internal POR.

8.5 Programming

8.5.1 SPI

The SPI provides a communication channel between the TPS65311-Q1 and a controller. The TPS65311-Q1 is always the slave. The controller is always the master. The SPI master selects the TPS65311-Q1 by setting CSN (chip select) to low. SDI (slave in) is the data input, SDO (slave out) is the data output, and SCK (serial clock input) is the SPI clock provided by the master. If chip select is not active (high), the data output SDO is high impedance. Each communication consist of 16 bits.

1 bit parity (odd) (parity is built over all bits including: R/W, CMD_ID[5:0], DATA[7:0])

1 bit R/W; read = 0 and write = 1

6 bits CMD identifier

8 bits data

| Bit15 | Bit14 | Bit13 | Bit12 | Bit11 | Bit10 | Bit9 | Bit8 | Bit7 | Bit6 | Bit5 | Bit4 | Bit3 | Bit2 | Bit1 | Bit0 |
|--------|-------|---------|---------|---------|---------|---------|---------|-------|-------|-------|-------|-------|-------|-------|-------|
| Parity | R/W | CMD_ID5 | CMD_ID4 | CMD_ID3 | CMD_ID2 | CMD_ID1 | CMD_ID0 | DATA7 | DATA6 | DATA5 | DATA4 | DATA3 | DATA2 | DATA1 | DATA0 |

Figure 25. SPI Bit-Frame

Each command is valid if:

- A valid CMD_ID is sent
- The parity bit (odd) is correct
- Exactly 16 SPI clocks are counted between falling and rising edge of CSN

The response to each master command is given in the following SPI cycle. The response address is the CMD_ID of the previous sent message and the corresponding data byte. The response data is latched with the previous cycle such that a response to a write command is the status of the register before the write access. (Same response as a read access.) The response to an invalid command is the original command with the correct parity bit. The response to an invalid number of SPI clock cycles is a SPI_SCK_FAIL communication (CMD_ID = 0x03). Write access to a read-only register is not reported as an SPI error and is treated as a read access. The initial answer after the first SPI command sent is: CMD_ID[5:0] = 0x3F and Data[7:0] 0x5A.

8.5.1.1 FSI Bit

The slave transmits an FSI bit between the falling edge of CSN and the rising edge of SCK. If the SDO line is high during this time, a failure occurred in the system and the MCU must use the PWR_STAT to get the root cause. A low level of SDO indicates normal operation of the device.

The FSI bit is set when: PWR_STAT \neq 0x00, or (SYS_STAT and 0x98) \neq 0x00, or SPI_STAT \neq 0x00. The FSI is cleared when all status flags are cleared.

8.6 Register Map

| CMD_ID | NAME | Bit7 | Bit6 | Bit5 | Bit4 | Bit3 | Bit2 | Bit1 | Bit0 |
|--------|--------------|-------------|-----------|----------|-------------|----------|------------|---------------|-------------|
| 0x00 | NOP | 0x00 | | | | | | | |
| 0x03 | SPI_SCK_FAIL | 1 | 0 | 0 | SCK_OF | SCK[3] | SCK[2] | SCK[1] | SCK[0] |
| 0x11 | LPM0_CMD | 0xAA | | | | | | | |
| 0x12 | LOCK_CMD | 0x55 | | | | | | | |
| 0x21 | PWR_STAT | BUCK_FAIL | VREG_FAIL | OT_BUCK | OT_LDO | OT_BOOST | LDO_FAIL | BOOST_FAIL | HS_OL |
| 0x22 | SYS_STAT | WD | POR | TestMode | SMPCLK_FAIL | EC_OF | EC2 | EC1 | EC0 |
| 0x23 | SPI_STAT | | | | | | CLOCK_FAIL | CMD_ID FAIL | PARITY FAIL |
| 0x24 | COMP_STAT | | | | | BUCK3-1 | BUCK3-0 | BUCK2-1 | BUCK2-0 |
| 0x29 | Serial Nr 1 | Bit [7:0] | | | | | | | |
| 0x2A | Serial Nr 2 | Bit [15:8] | | | | | | | |
| 0x2B | Serial Nr 3 | Bit [23:16] | | | | | | | |
| 0x2C | Serial Nr 4 | Bit [31:24] | | | | | | | |
| 0x2D | Serial Nr 5 | Bit [39:32] | | | | | | | |
| 0x2E | Serial Nr 6 | Bit [47:40] | | | | | | | |
| 0x2F | DEV_REV | Major3 | Major2 | Major1 | Major0 | Minor3 | Minor2 | Minor1 | Minor0 |
| 0x31 | PWR_CONFIG | | BUCK2_EN | BUCK3_EN | LDO_EN | BOOST_EN | HS_EN | GPFET_OV_HIGH | IRQ_THRES |
| 0x32 | DEV_CONFIG | | | | | HL_CLDIS | VT_EN | RSV | RSV |
| 0x33 | CLOCK_CONFIG | F_EN | SS_EN | SS_MODE | F4 | F3 | F2 | F1 | F0 |

8.6.1 Register Description

| NOP 0x00 | | | | | | | | |
|-------------|------|------|------|------|------|------|------|------|
| | Bit7 | Bit6 | Bit5 | Bit4 | Bit3 | Bit2 | Bit1 | Bit0 |
| After RESET | 0 | 0 | 0 | 0 | 0 | 0 | 0 | 0 |
| Read | 0 | 0 | 0 | 0 | 0 | 0 | 0 | 0 |
| Write | d.c. | d.c. | d.c. | d.c. | d.c. | d.c. | d.c. | d.c. |

| SPI_SCK_FAIL 0x03 | | | | | | | | |
|---------------------|------|------|------|--------|--------|--------|--------|--------|
| | Bit7 | Bit6 | Bit5 | Bit4 | Bit3 | Bit2 | Bit1 | Bit0 |
| Default after RESET | 1 | 0 | 0 | 0 | 0 | 0 | 0 | 0 |
| Read | 1 | 0 | 0 | SCK_OF | SCK[3] | SCK[2] | SCK[1] | SCK[0] |
| Write | d.c. | d.c. | d.c. | d.c. | d.c. | d.c. | d.c. | d.c. |

| BIT NAME | BIT NO. | DESCRIPTION |
|---|---------|--|
| SCK_OF | 4 | Between a falling and a rising edge of CSN, the number of SCK was greater than 16. 0: 1: Number of SCK cycles was > 16 |
| Comment: This flag is cleared after its content is transmitted to the master. | | |

| BIT NAME | BIT NO. | DESCRIPTION |
|---|---------|--|
| SCK[3:0] | 3:0 | The number of rising edges on SCK between a falling and a rising edge of CSN minus 1. Saturates at 0xF if 16 or more edges are received. |
| Comment: This flag is cleared after its content is transmitted to the master. | | |

| LPM0_CMD 0x11 | | | | | | | | |
|---|------|------|------|------|------|------|------|------|
| | Bit7 | Bit6 | Bit5 | Bit4 | Bit3 | Bit2 | Bit1 | Bit0 |
| After RESET | 0 | 0 | 0 | 0 | 0 | 0 | 0 | 0 |
| Read | 0 | 0 | 0 | 0 | 0 | 0 | 0 | 0 |
| Write | 0xAA | | | | | | | |
| This command is used to send the device into LPM0 mode. | | | | | | | | |

TPS65311-Q1

SLVSCA6C – OCTOBER 2013 – REVISED OCTOBER 2017

www.ti.com

| LOCK_CMD 0x12 | | | | | | | | |
|---------------|------|------|------|------|------|------|------|------|
| | Bit7 | Bit6 | Bit5 | Bit4 | Bit3 | Bit2 | Bit1 | Bit0 |
| After RESET | 0 | 0 | 0 | 0 | 0 | 0 | 0 | 0 |
| Read | 0 | 0 | 0 | 0 | 0 | 0 | 0 | 0 |
| Write | 0x55 | | | | | | | |

Sending a lock command (0x55) brings the device into LOCK mode. Only a POR brings the device out of this state.

| PWR_STAT 0x21 | | | | | | | | |
|-------------------|-----------|-----------|---------|--------|----------|----------|------------|-------|
| | Bit7 | Bit6 | Bit5 | Bit4 | Bit3 | Bit2 | Bit1 | Bit0 |
| Default after POR | 0 | 0 | 0 | 0 | 0 | 0 | 0 | 0 |
| Read | BUCK_FAIL | VREG_FAIL | OT_BUCK | OT_LDO | OT_BOOST | LDO_FAIL | BOOST_FAIL | HS_OL |
| Write | d.c. | d.c. | d.c. | d.c. | d.c. | d.c. | d.c. | d.c. |

| BIT NAME | BIT NO. | DESCRIPTION |
|-----------|---------|---|
| BUCK_FAIL | 7 | BUCK power fail flag 0: 1: Power stages shutdown detected caused by OC BUCK1, UV, OV, loss of GND (BOOST + all bucks) |

BUCK_FAIL flag is cleared in case the fail condition is not present anymore and the flag is transmitted to the master.

| BIT NAME | BIT NO. | DESCRIPTION |
|-----------|---------|--|
| VREG_FAIL | 6 | Internal voltage regulator too low 0: 1: VREG fail |

VREG_FAIL flag is cleared in case the fail condition is not present anymore and the flag is transmitted to the master.

| BIT NAME | BIT NO. | DESCRIPTION |
|----------|---------|--|
| OT_BUCK | 5 | BUCK1-3 overtemperature flag 0: 1: IC power stages shutdown due to overtemperature |

OT flag is cleared in case the fail condition is not present anymore and the flag is transmitted to the master.

| BIT NAME | BIT NO. | DESCRIPTION |
|----------|---------|--|
| OT_LDO | 4 | LDO overtemperature flag 0: 1: LDO shutdown due to overtemperature |

OT flag is cleared in case the fail condition is not present anymore and the flag is transmitted to the master.

| BIT NAME | BIT NO. | DESCRIPTION |
|----------|---------|--|
| OT_BOOST | 3 | Boost overtemperature flag 0: 1: BOOST shutdown due to overtemperature |

OT flag is cleared in case the fail condition is not present anymore and the flag is transmitted to the master.

| BIT NAME | BIT NO. | DESCRIPTION |
|----------|---------|---|
| LDO_FAIL | 2 | LDO under or overvoltage flag 0: 1: LDO out of regulation |

LDO_FAIL flag is cleared if there is no undervoltage and no overvoltage and the flag is transmitted to the master.

| BIT NAME | BIT NO. | DESCRIPTION |
|---|---------|--|
| BOOST_FAIL | 1 | Booster under or overvoltage flag or loss of GND 0: 1: Booster out of regulation |
| BOOST_FAIL flag is cleared if there is no undervoltage and no overvoltage and the flag was transmitted to the master. | | |

| BIT NAME | BIT NO. | DESCRIPTION |
|---|---------|---|
| HS_OL | 0 | High-side switch open load condition 0: 1: Open load at high side |
| Bit indicates current OL condition of high side (no flag) | | |

| SYS_STAT 0x22 | | | | | | | | |
|-------------------|------|------|----------|-------------|------|------|------|------|
| | Bit7 | Bit6 | Bit5 | Bit4 | Bit3 | Bit2 | Bit1 | Bit0 |
| Default after POR | 0 | 0 | 0 | 0 | 0 | 0 | 0 | 1 |
| Read | WD | POR | Testmode | SMPCLK_FAIL | 0 | EC2 | EC1 | EC0 |
| Write | d.c. | d.c. | d.c. | d.c. | d.c. | d.c. | d.c. | d.c. |

| BIT NAME | BIT NO. | DESCRIPTION |
|---|---------|---|
| WD | 7 | Watchdog reset flag 0: 1: Last reset caused by watchdog |
| Comment: This flag is cleared after its content is transmitted to the master. | | |

| BIT NAME | BIT NO. | DESCRIPTION |
|---|---------|--|
| POR | 6 | Power-on reset flag 0: 1: Last reset caused by a POR condition |
| Comment: This flag is cleared after its content is transmitted to the master. | | |

| BIT NAME | BIT NO. | DESCRIPTION |
|---|---------|---|
| Testmode | 5 | If this bit is set, the device entered test mode 0: 1: Device in Testmode |
| Comment: This flag is cleared after its content is transmitted to the master and the device left the test mode. | | |

| BIT NAME | BIT NO. | DESCRIPTION |
|---|---------|---|
| SMPCLK_FAIL | 4 | If this bit is set, the clock of the switch mode power supplies is too low. 0: Clock OK 1: Clock fail |
| Comment: This flag is cleared after its content is transmitted to the master. | | |

| BIT NAME | BIT NO. | DESCRIPTION |
|---|---------|---|
| EC [2:0] | 0-2 | Actual error flag counter 0: - 1: - |
| *Error Counter is only deleted with a POR | | |

TPS65311-Q1

SLVSCA6C – OCTOBER 2013 – REVISED OCTOBER 2017

www.ti.com

| SPI_STAT 0x23 | | | | | | | | |
|---------------------|------|------|------|------|------|------------|-------------|-------------|
| | Bit7 | Bit6 | Bit5 | Bit4 | Bit3 | Bit2 | Bit1 | Bit0 |
| Default after RESET | 0 | 0 | 0 | 0 | 0 | 0 | 0 | 0 |
| Read | 0 | 0 | 0 | 0 | 0 | CLOCK_FAIL | CMD_ID FAIL | PARITY FAIL |
| Write | d.c. | d.c. | d.c. | d.c. | d.c. | d.c. | d.c. | d.c. |

| BIT NAME | BIT NO. | DESCRIPTION |
|------------|---------|---|
| CLOCK_FAIL | 2 | Between a falling and a rising edge of CSN, the number of SCK does not equal 16 0: 1: Wrong SCK |

Comment: This flag is cleared after its content is transmitted to the master.

| BIT NAME | BIT NO. | DESCRIPTION |
|-------------|---------|--|
| CMD_ID FAIL | 1 | Last received CMD_ID in a reserved area 0: 1: Wrong CMD_ID |

Comment: This flag is cleared after its content is transmitted to the master and is not set if the number of SCK cycles is incorrect.

| BIT NAME | BIT NO. | DESCRIPTION |
|-------------|---------|---|
| PARITY_FAIL | 0 | Last received command has a parity bit failure 0: 1: Parity bit error |

Comment: This flag is cleared after its content is transmitted to the master and is not set if the number of SCK cycles is incorrect.

| COMP_STAT 0x24 | | | | | | | | |
|---------------------|------|------|------|------|---------|---------|---------|---------|
| | Bit7 | Bit6 | Bit5 | Bit4 | Bit3 | Bit2 | Bit1 | Bit0 |
| Default after RESET | 0 | 0 | 0 | 0 | 0 | 1 | 1 | 0 |
| Read | 0 | 0 | 0 | 0 | BUCK3-1 | BUCK3-0 | BUCK2-1 | BUCK2-0 |
| Write | d.c. | d.c. | d.c. | d.c. | d.c. | d.c. | d.c. | d.c. |

Register to read back the actual BUCK2/3 compensation settings on COMP2/3. 0x1 ≥ 0 V 0 x 2 ≥ VREG 0 x 3 ≥ open

| DEV_REV 0x2F | | | | | | | | |
|--------------|--------|--------|--------|--------|--------|--------|--------|--------|
| | Bit7 | Bit6 | Bit5 | Bit4 | Bit3 | Bit2 | Bit1 | Bit0 |
| After RESET | Major3 | Major2 | Major1 | Major0 | Minor3 | Minor2 | Minor1 | Minor0 |
| Read | Major3 | Major2 | Major1 | Major0 | Minor3 | Minor2 | Minor1 | Minor0 |
| Write | d.c. | d.c. | d.c. | d.c. | d.c. | d.c. | d.c. | d.c. |

Hard coded device revision can be read from this register

| PWR_CONFIG 0x31 | | | | | | | | |
|---------------------|------|----------|----------|--------|----------|-------|----------------|-----------|
| | Bit7 | Bit6 | Bit5 | Bit4 | Bit3 | Bit2 | Bit1 | Bit0 |
| Default after RESET | 0 | 1 | 1 | 0 | 1 | 0 | 0 | 0 |
| Read | 0 | BUCK2_EN | BUCK3_EN | LDO_EN | BOOST_EN | HS_EN | GP_FET_OV_HIGH | IRQ_THRES |
| Write | 0 | BUCK2_EN | BUCK3_EN | LDO_EN | BOOST_EN | HS_EN | GP_FET_OV_HIGH | IRQ_THRES |

This register contains all power rail enable bits.

| BIT NAME | BIT NO. | DESCRIPTION |
|-------------------------------|---------|--|
| BUCK2_EN | 6 | BUCK2 enable flag 0: 1: Enable BUCK2 |
| After reset, BUCK2 is enabled | | |

| BIT NAME | BIT NO. | DESCRIPTION |
|-------------------------------|---------|--|
| BUCK3_EN | 5 | BUCK3 enable flag 0: 1: Enable BUCK3 |
| After reset, BUCK3 is enabled | | |

| BIT NAME | BIT NO. | DESCRIPTION |
|------------------------------|---------|---|
| LDO_EN | 4 | LDO enable flag 0: 1: LDO enabled |
| After reset, LDO is disabled | | |

| BIT NAME | BIT NO. | DESCRIPTION |
|-------------------------------|---------|--|
| BOOST_EN | 3 | BOOST enable 0: 1: BOOST enabled |
| After reset, BOOST is enabled | | |

| BIT NAME | BIT NO. | DESCRIPTION |
|------------------------------------|---------|--|
| HS_EN | 2 | LED and high-side switch enable 0: High side disabled 1: High side enabled |
| After reset, high side is disabled | | |

| BIT NAME | BIT NO. | DESCRIPTION |
|--|---------|---|
| GPFET_OV_HIGH | 1 | Protection FET overvoltage shutdown 0: Protection FET switches off at $V_{IN} > V_{OVTH-L}$ 1: Protection FET switches off at $V_{IN} > V_{OVTH-H}$ |
| After reset, the lower VIN protection threshold is enabled | | |

| BIT NAME | BIT NO. | DESCRIPTION |
|---|---------|---|
| IRQ_THRES | 0 | VSSENSE IRQ low voltage interrupt threshold select 0: Low threshold selected ($V_{SSENSETH-L}$) 1: High threshold selected ($V_{SSENSETH-H}$) |
| After reset, the lower VBAT monitoring threshold is enabled | | |

| DEV_CONFIG 0x32 | | | | | | | | |
|---------------------|------|------|------|------|------|-------|------|------|
| | Bit7 | Bit6 | Bit5 | Bit4 | Bit3 | Bit2 | Bit1 | Bit0 |
| Default after RESET | 0 | 0 | 0 | 0 | 0 | 1 | 1 | 0 |
| Read | 0 | 0 | 0 | 0 | 0 | VT_EN | RSV | RSV |
| Write | d.c. | d.c. | d.c. | d.c. | d.c. | VT_EN | 1 | 0 |

TPS65311-Q1

SLVSCA6C – OCTOBER 2013 – REVISED OCTOBER 2017

www.ti.com

| BIT NAME | BIT NO. | DESCRIPTION |
|----------|---------|---|
| HS_CLDIS | 3 | LED and high-side switch current limit counter disable bit 0: LED and high-side switch current limit counter enabled 1: LED and high-side switch current limit counter disabled |

| BIT NAME | BIT NO. | DESCRIPTION |
|----------|---------|--|
| VT_EN | 2 | VT enable bit 0: VT monitor disabled 1: VT monitor enabled |

The VT monitor cannot be turned on after it was turned off. Turn on only happens during power up in the VTCHECK state.

| BIT NAME | BIT NO. | DESCRIPTION |
|----------|---------|--|
| RSV | 1 | Voltage reference enable bit 0: not recommended setting 1: default setting |

| BIT NAME | BIT NO. | DESCRIPTION |
|----------|---------|---|
| RSV | 0 | Reserved - keep this bit at 1 0: default setting 1: not recommended setting |

| CLOCK_CONFIG 0x33 | | | | | | | | |
|---------------------|------|-------|---------|------|------|------|------|------|
| | Bit7 | Bit6 | Bit5 | Bit4 | Bit3 | Bit2 | Bit1 | Bit0 |
| Default after RESET | 0 | 0 | 0 | 1 | 0 | 0 | 0 | 0 |
| Read | F_EN | SS_EN | SS_MODE | F4 | F3 | F2 | F1 | F0 |
| Write | F_EN | SS_EN | SS_MODE | F4 | F3 | F2 | F1 | F0 |

| BIT NAME | BIT NO. | DESCRIPTION |
|----------|---------|---|
| F_EN | 7 | Frequency tuning enable register 0: Off – Setting of Bit4...Bit0 are not effective, setting of Bit6 and Bit5 become effective 1: On – Setting of Bit4...Bit0 become effective, setting of Bit6 and Bit5 are not effective |

| BIT NAME | BIT NO. | DESCRIPTION |
|----------|---------|---|
| SS_EN | 6 | Spread spectrum mode enable 0: Spread spectrum option for all switching regulators disabled 1: Spread spectrum option for all switching regulators enabled (only when F_EN = 0) |

When enabled, the switching frequency of BUCK1/2/3 and BOOST is modulated between $0.8 \times f_{osc}$ and f_{osc}

| BIT NAME | BIT NO. | DESCRIPTION |
|----------|---------|---|
| SS_MODE | 5 | Spread spectrum mode select (effective only when F_EN = 0) 0: Pseudo random 1: Triangular |

| BIT NAME | BIT NO. | DESCRIPTION |
|--------------------|---------|--|
| F4, F3, F2, F1, F0 | 4-0 | Frequency tuning register (effective only when F_EN = 1) |

0x10 is default value, trim range is 25% for 0x00 setting to –20% for 0x1F setting. Frequency tuning influences the switching frequency of BUCK1/2/3 and BOOST as well as the watchdog timing.

Typical Applications (continued)

9.2.1.1 Design Requirements

For this design example, use the parameters listed in [Table 2](#).

Table 2. Design Parameters

| DESIGN PARAMETER | EXAMPLE VALUE |
|---|---------------|
| Input voltage | 12 V |
| Output voltage (V_{BUCK1}) | 3.3 V |
| Maximum output current ($I_{\text{max_peak_coil}}$) | 2.3 A |
| Load Step ΔI_{OUT} | 1 A |
| Output current ripple $I_{\text{L_ripple}}$ | 500 mA |
| Output voltage ripple | 3 mV |
| Allowed voltage step on output ΔV_{OUT} | 0.198 (or 6%) |
| Switching frequency (f_{SWBUCK1}) | 490 kHz |
| Bandwidth (F_{BW}) | ≈ 60 kHz |

9.2.1.2 Detailed Design Procedure

9.2.1.2.1 Adjusting the Output Voltage for the BUCK1 Controller

A resistor divider from the output node to the VSENSE1 pin sets the output voltage. TI recommends using 1% tolerance or better divider resistors. Start with 16 k Ω for the R1 resistor and use [Equation 1](#) to calculate R2 (see [Figure 26](#)).

$$R_2 = \frac{R_1 \times (V_{\text{BUCK1}} - 0.8 \text{ V})}{0.8 \text{ V}} \quad (1)$$

Therefore, for the value of V_{BUCK1} to equal to 3.3 V, the value of R2 must be 50 k Ω .

For voltage monitoring of the BUCK1 output voltage, placing an additional resistive divider with the exact same values from the output node to the VMON1 pin is recommended for safety reasons (see [Figure 26](#)). If no safety standard must be fulfilled in the application, the VMON1 pin can be directly connected to VSENSE1 pin without the need for this additional resistive divider.

9.2.1.2.2 Output Inductor, Sense Resistor, and Capacitor Selection for the BUCK1 Controller

An external resistor senses the current through the inductor. The current sense resistor pins (S1 and S2) are fed into an internal differential amplifier which supports the range of V_{BUCK1} voltages. The sense resistor R_s must be chosen so that the maximum forward peak current in the inductor generates a voltage of 75 mV across the sense pins. This specified typical value is for low duty cycles only. At typical duty-cycle conditions around 28% (assuming 3.3-V output and 12-V input), 50 mV is a more reasonable value, considering tolerances and mismatches. The typical characteristics (see [Figure 2](#)) provide a guide for using the correct current-limit sense voltage.

$$R_s = \frac{60 \text{ mV}}{I_{\text{max_peak}}} \quad (2)$$

Optimal slope compensation which is adaptive to changes in input voltage and duty cycle allows stable operation at all conditions. In order to specify optimal performance of this circuit, the following condition must be satisfied in the choice of inductor and sense resistor:

$$L = 410 \times R_s$$

where

- L = inductor in μH
 - R_s = sense resistor in Ω
- (3)

The current sense pins S1 and S2 are high impedance pins with low leakage across the entire V_{BUCK1} range. This allows DCR current sensing (see [Figure 16](#)) using the DC resistance of the inductor for better efficiency.

For selecting the output capacitance and its ESR resistance, the following set of equations can be used:

$$C_{OUT} > \frac{2 \times \Delta I_{OUT}}{f_{SW} \times \Delta V_{OUT}}$$

$$C_{OUT} > \frac{1}{8 \times f_{SW}} \times \frac{I_{L_ripple}}{V_{o_ripple}}$$

$$R_{ESR} < \frac{V_{o_ripple}}{I_{L_ripple}}$$

where

- f_{sw} is the 490-kHz switching frequency
 - ΔI_{OUT} is the worst-case load step from the application
 - ΔV_{OUT} is the allowed voltage step on the output
 - V_{o_ripple} is the allowed output voltage ripple
 - I_{L_ripple} is the ripple current in the coil
- (4)

9.2.1.2.3 Compensation of the Buck Controller

The main buck controller requires external type 2 compensation on pin COMP1 for normal mode operation. The components can be calculated as follows.

1. Select a value for the bandwidth, F_{BW} , to be between $f_{SWBUCK1} / 6$ (faster response) and $f_{SWBUCK1} / 10$ (more conservative)
2. Use Equation 5 to select a value for R3 (see Figure 16).

$$R3 = \frac{2\pi \times F_{BW} \times V_{OUT1} \times C_{OUT1}}{gm \times K_{CFB} \times V_{refBUCK}}$$

where

- C_{OUT1} is the load capacitance of BUCK1
 - gm is the error amplifier transconductance
 - $K_{CFB} = 0.125 / R_s$
 - $V_{refBUCK}$ is the internal reference voltage
- (5)

3. Use Equation 6 to select a value for C1 (in series with R3, see Figure 16) to set the zero frequency close to $F_{BW} / 10$.

$$C1 = \frac{10}{2\pi \times R3 \times F_{BW}}$$

(6)

4. Use Equation 7 to select a value for C2 (parallel with R3, C1, see Figure 16) to set the second pole below $f_{SWBUCK1} / 2$

$$C2 = \frac{1}{2\pi \times R3 \times F_{BW} \times 3}$$

(7)

For example:

$$f_{SWBUCK1} = 490 \text{ kHz}, V_{refBUCK} = 0.8 \text{ V}, F_{BW} = 60 \text{ kHz}$$

$$V_{OUT1} = 3.3 \text{ V}, C_{OUT1} = 100 \text{ } \mu\text{F}, R_s = 22 \text{ m}\Omega$$

$$\text{Selected values: } R3 = 24 \text{ k}\Omega, C1 = 1.2 \text{ nF}, C2 = 33 \text{ pF}$$

$$\text{Resulting in } F_{BW}: 58 \text{ kHz}$$

$$\text{Resulting in zero frequency: } 5.5 \text{ kHz}$$

$$\text{Resulting in second pole frequency: } 201 \text{ kHz}$$

Stability and load step response must be verified in measurements to fine tune the values of the compensation components.

9.2.1.2.4 Bootstrap Capacitor for the BUCK1 Controller

The BUCK1 controller requires a bootstrap capacitor. This bootstrap capacitor must be 0.1 μF . The bootstrap capacitor is located between the PH1 pin and the BOOT1 pin (see Figure 26). The bootstrap capacitor must be a high-quality ceramic type with X7R or X5R grade dielectric for temperature stability.

9.2.1.3 BUCK 1 Application Curve

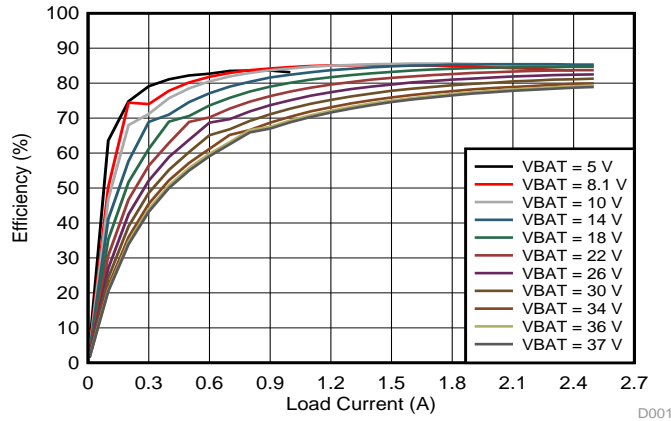
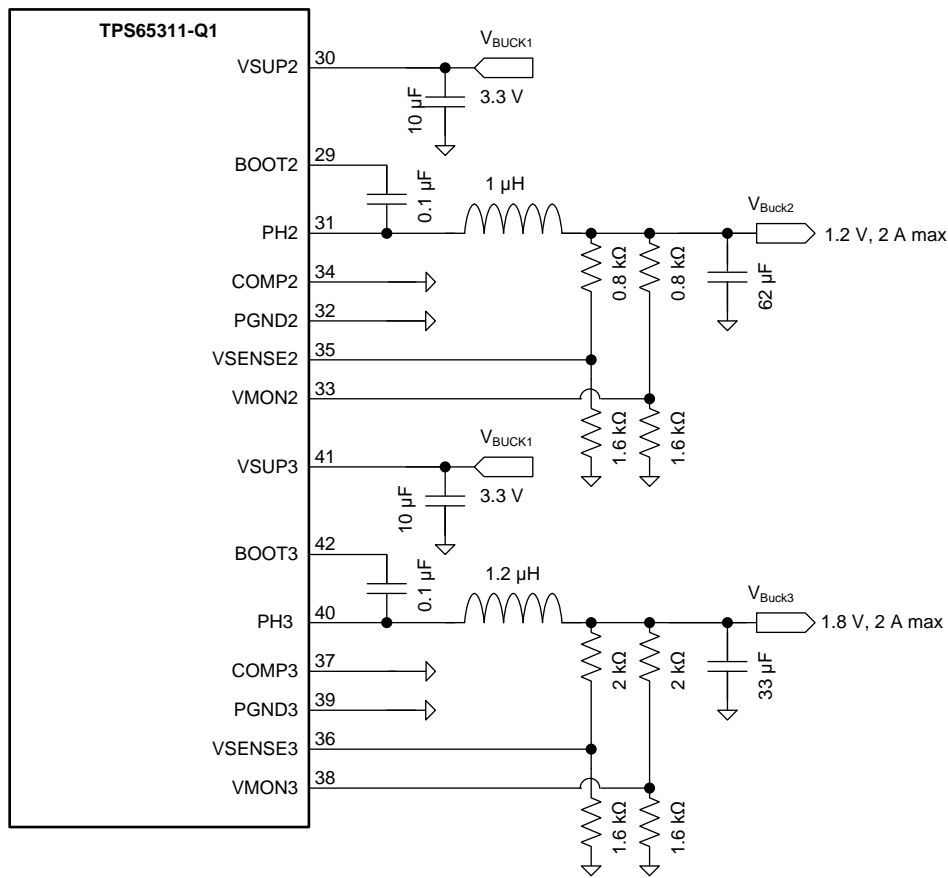

Figure 27. Efficiency Results of Buck1

9.2.2 Synchronous Buck Converters BUCK2 and BUCK3



Copyright © 2017, Texas Instruments Incorporated

Figure 28. Synchronous Buck Converter Schematic

9.2.2.1 Design Requirements

For this design example, use the parameters listed in [Table 3](#).

Table 3. Design Parameters

| DESIGN PARAMETER | EXAMPLE VALUE |
|---|----------------|
| Input voltage | 3.3 V |
| Output voltage ($V_{\text{BUCK2/3}}$) | 1.2 V 1.8 V |
| Maximum output current ($I_{\text{max_peak}}$) | 2 A |
| Output current ripple $\Delta I_{\text{L_PP}}$ | 300 mA |
| Switching frequency ($f_{\text{SWBUCK2/3}}$) | 2.45 MHz |

9.2.2.2 Detailed Design Procedure

9.2.2.2.1 Adjusting the Output Voltage for the BUCK2 and BUCK3 Converter

A resistor divider from the output node to the VSENSE2 to ground respectively between the VSENSE3 to ground pin sets the output voltage (see [Figure 28](#)). TI recommends using 1% tolerance or better divider resistors. Start by selecting 1.6 k Ω for the value of the R_x resistor between the VSENSE2 to ground respectively between the VSENSE3 to ground pin VSENSE3 pin and use [Equation 8](#) to calculate the value for the R_y resistor between BUCK2 and BUCK3 output and the VSENSE2 to ground respectively between the VSENSE3 to ground pin.

$$R_y = \frac{R_x \times (V_{\text{BUCK2/3}} - 0.8 \text{ V})}{0.8 \text{ V}} \quad (8)$$

Therefore, for V_{BUCK2} to equal to 1.2 V, the value of R_y must be 0.8 k Ω . For V_{BUCK3} to equal to 1.8 V, the value of R_y must be 2 k Ω .

For voltage monitoring of the BUCK2 and BUCK3 output voltage, placing an additional resistive divider with exact same values from the output node to the VMON2 and VMON3 pins is recommended for safety reasons (see [Figure 28](#)). If no safety standard must be fulfilled in the application, the VMON2 and VMON3 pins can be directly connected to VSENSE2 and VSENSE3 pins without the need for this additional resistive divider.

9.2.2.2.2 Output Inductor Selection for the BUCK2 and BUCK3 Converter

The inductor value L depends on the allowed ripple current $\Delta I_{\text{L_PP}}$ in the coil at chosen input voltage V_{IN} and output voltage V_{OUT} , and given switching frequency f_{sw} :

$$L = \frac{V_{\text{OUT}} \times (V_{\text{IN}} - V_{\text{OUT}})}{\Delta I_{\text{L_PP}} \times V_{\text{IN}} \times f_{\text{sw}}} \quad (9)$$

For example:

$$\begin{aligned} V_{\text{IN}} &= 3.3 \text{ V (from BUCK1)} \\ V_{\text{OUT}} &= 1.2 \text{ V} \\ \Delta I_{\text{L_PP}} &= 300 \text{ mA} \\ f_{\text{sw}} &= 2.45 \text{ MHz} \\ \rightarrow L &\approx 1 \mu\text{H} \end{aligned}$$

9.2.2.2.3 Compensation of the BUCK2 and BUCK3 Converters

The regulators operate in forced continuous mode, and have internal frequency compensation. The frequency response can be adjusted to the selected LC filter by setting the COMP2 and COMP3 pin low, high, or floating. After selecting the output inductor value as previously described, the output capacitor must be chosen so that the $L \times C_{OUT} \times V_{BUCK2/3}$ product is equal to or less than one of the three values, as listed in Table 4.

Table 4. Compensation Settings

| COMP 2/3 | $L \times C_{OUT} \times V_{BUCK2/3}$ | EXAMPLE COMPONENTS |
|----------|--|--|
| = 0 V | $80 \mu\text{F} \times \mu\text{H} \times \text{V}$ | $30 \mu\text{F} \times 2.2 \mu\text{H} \times 1.2 \text{V}$ |
| = OPEN | $160 \mu\text{F} \times \mu\text{H} \times \text{V}$ | $50 \mu\text{F} \times 1.8 \mu\text{H} \times 1.8 \text{V}$ |
| = VREG | $320 \mu\text{F} \times \mu\text{H} \times \text{V}$ | $150 \mu\text{F} \times 2.2 \mu\text{H} \times 1.2 \text{V}$ |

Larger output capacitors can be used if a feed-forward capacitor is placed across the upper resistance, R_y , of the feedback divider. This works effectively for output voltages $> 2 \text{V}$. With an RC product greater than $10 \mu\text{s}$, the effective $V_{BUCK2/3}$ at higher frequencies can be assumed as 0.8V , thus allowing an output capacitor increase by a factor equal to the ratio of the output voltage to 0.8V .

9.2.2.2.4 Bootstrap Capacitor for the BUCK2/3 Converters

The BUCK2 and BUCK3 converters require a bootstrap capacitor. This bootstrap capacitor must be $0.1 \mu\text{F}$. The bootstrap capacitor is located between the PH2 pin and the BOOT2 pin and between the PH3 pin and the BOOT3 pin (see Figure 28). The bootstrap capacitor must be a high-quality ceramic type with X7R or X5R grade dielectric for temperature stability.

9.2.2.3 BUCK2 and BUCK3 Application Curves

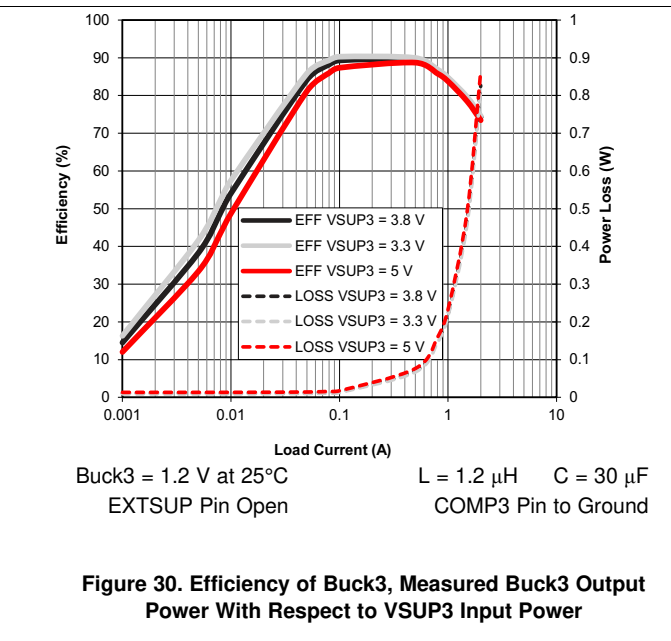
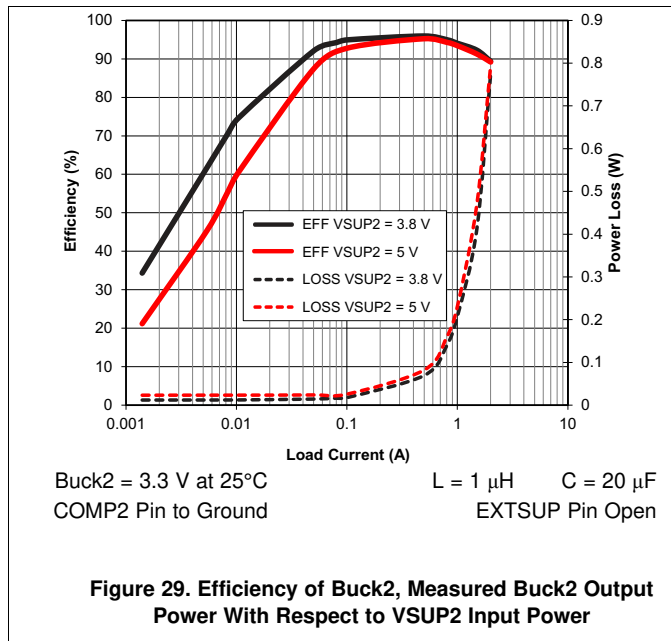

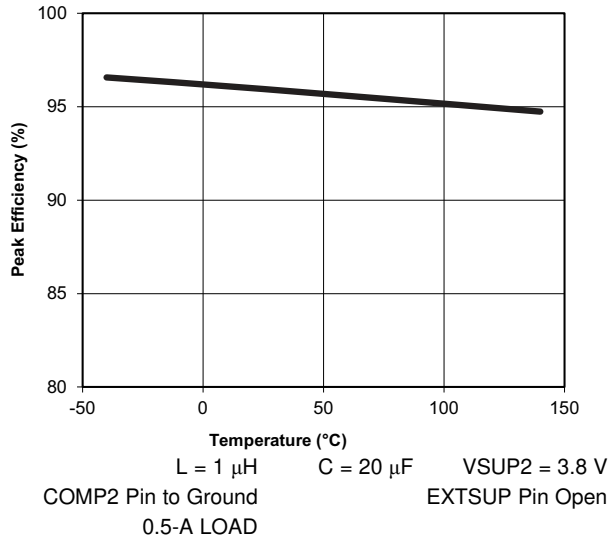

Figure 31. Buck2 = 3.3-V Efficiency at 0.5 A Versus Temperature, Measured Buck2 Output Power With Respect to VSUP2 Input Power

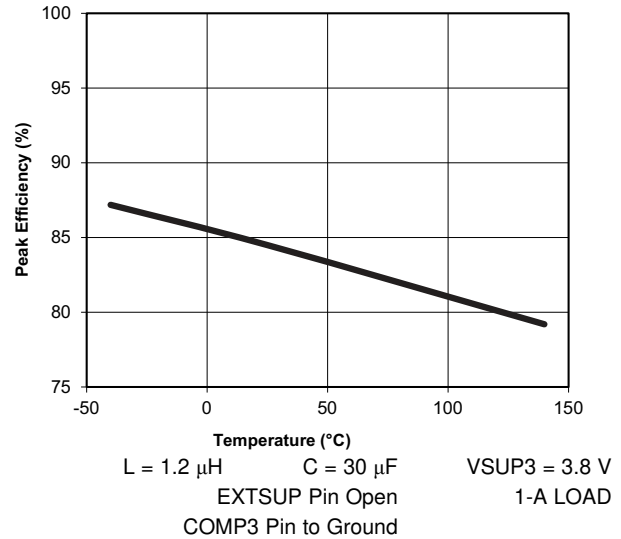

Figure 32. Buck3 = 1.2-V Efficiency at 1 A Versus Temperature, Measured Buck3 Output Power With Respect to VSUP3 Input Power

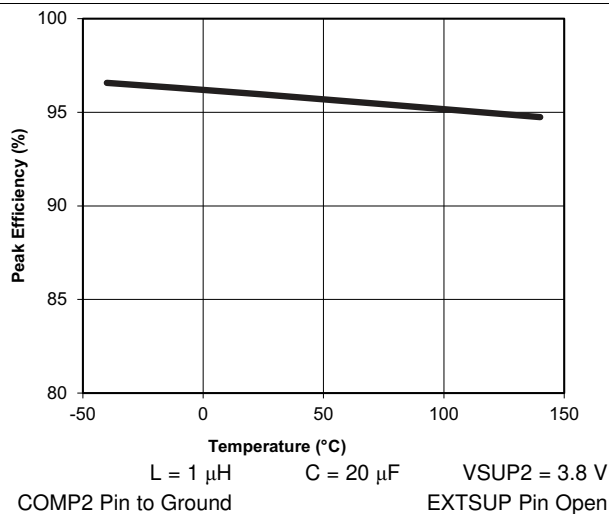

Figure 33. Buck2 = 3.3-V Peak Efficiency Versus Temperature, Measured Buck2 Output Power With Respect to VSUP2 Input Power

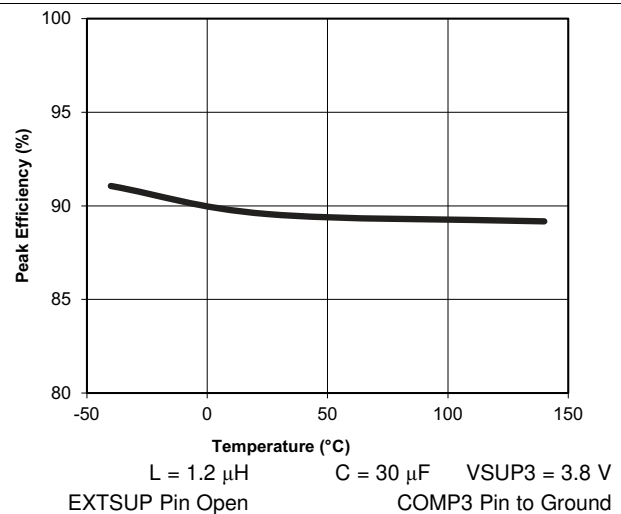
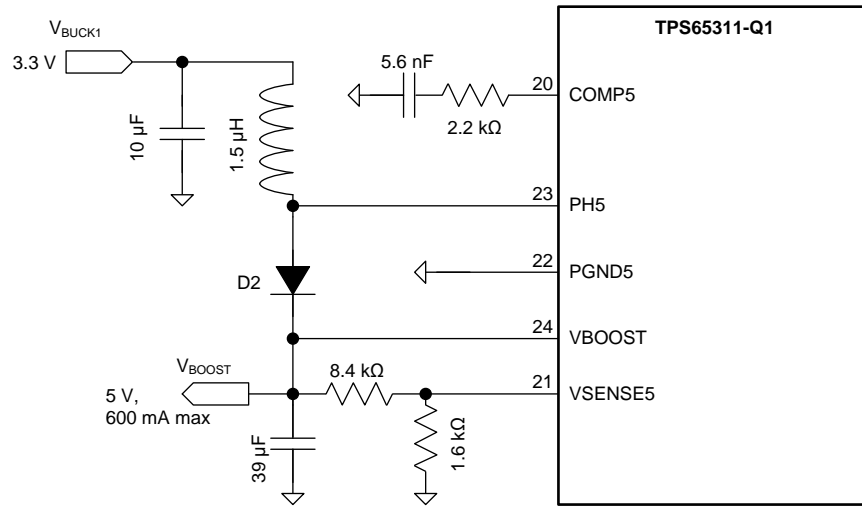

Figure 34. Buck3 = 1.2-V Peak Efficiency Versus Temperature, Measured Buck3 Output Power With Respect to VSUP3 Input Power

9.2.3 BOOST Converter



Copyright © 2017, Texas Instruments Incorporated

Figure 35. BOOST Converter Schematic

9.2.3.1 Design Requirements

For this design example, use the parameters listed in Table 5.

Table 5. Design Parameters

| DESIGN PARAMETER | EXAMPLE VALUE |
|---|---------------|
| Input voltage | 3.3 V |
| Output voltage (V _{BOOST}) | 5 V |
| Peak coil current (I _{peak_coil}) | 1 A |
| Maximum output current I _{OUT} | ≈ 600 mA |
| Output current ripple ΔI _{L_PP} | 300 mA |
| Switching frequency (f _{SWBOOST}) | 2.45 MHz |

9.2.3.2 Detailed Design Procedure

9.2.3.2.1 Adjusting the Output Voltage for the Boost Converter

A resistor divider from the output node to the VSENSE5 pin sets the output voltage. TI recommends using 1% tolerance or better divider resistors. Start with a value of 1.6 kΩ for the R_x resistor and use Equation 10 to calculate R_y (see Figure 35).

$$R_y = \frac{R_x \times (V_{BOOST} - 0.8 \text{ V})}{0.8 \text{ V}} \tag{10}$$

Therefore, for the value of V_{BOOST} to equal to 5 V, the value of R_y must be 8.4 kΩ.

9.2.3.2.2 Output Inductor and Capacitor Selection for the BOOST Converter

The inductor value L depends on the allowed ripple current ΔI_{L_PP} in the coil at chosen input voltage V_{IN} and output voltage V_{OUT}, and given switching frequency f_{sw}:

$$L = \frac{V_{IN} \times (V_{OUT} - V_{IN})}{\Delta I_{L_PP} \times V_{OUT} \times f_{sw}} \tag{11}$$

For example:

$$V_{IN} = 3.3 \text{ V (from BUCK1)}$$

$$V_{OUT} = 5 \text{ V}$$

$$\begin{aligned}\Delta I_{L_PP} &= 300 \text{ mA (30\% of 1-A peak current)} \\ f_{sw} &= 2.45 \text{ MHz} \\ \rightarrow L &\approx 1.5 \text{ }\mu\text{H}\end{aligned}$$

The capacitor value C_{OUT} must be selected such that the L-C double-pole frequency F_{LC} is in the range of 10 kHz–15 kHz. The F_{LC} is given by [Equation 12](#):

$$F_{LC} = \frac{V_{IN}}{2 \times \pi \times V_{OUT} \times \sqrt{L \times C_{OUT}}} \quad (12)$$

The right half-plane zero F_{RHPZ} , as given in [Equation 13](#), must be > 200 kHz:

$$F_{RHPZ} = \frac{V_{IN}^2}{2 \times \pi \times L \times I_{OUT} \times V_{OUT}} > 200 \text{ kHz}$$

where

- I_{OUT} represents the load current (13)

If the condition $F_{RHPZ} > 200$ kHz is not satisfied, L and therefore C_{OUT} have to be recalculated.

9.2.3.2.3 Compensation of the BOOST Converter

The BOOST converter requires an external R-C network for compensation (see [Figure 15](#), COMP5). The components can be calculated using [Equation 14](#) and [Equation 15](#):

$$R = 120 \times V_{IN} \times \left(\frac{F_{BW}}{F_{LC}} \right)^2 \quad (14)$$

$$C = \frac{1}{2 \times \pi \times R \times F_{LC}}$$

where

- F_{BW} represents the bandwidth of the regulation loop, and must be set to 30 kHz
- F_{LC} represents the L-C double-pole frequency, as mentioned previously (15)

For example:

$$\begin{aligned}V_{IN} &= 3.3 \text{ V (from BUCK1)} \\ V_{OUT} &= 5 \text{ V} \\ L &= 1.5 \text{ }\mu\text{H} \\ C &= 39 \text{ }\mu\text{F} \\ \rightarrow F_{LC} &= 13.7 \text{ kHz} \\ F_{BW} &= 30 \text{ kHz} \\ \rightarrow R &\approx 2.2 \text{ k}\Omega \\ \rightarrow C &\approx 5.6 \text{ nF}\end{aligned}$$

Stability and load step response must be verified in measurements to fine tune the values of the compensation components.

9.2.3.2.4 Output Diode for the BOOST Converter

The BOOST converter requires an external output diode between the PH5 pin and VBOOST pin (see [Figure 35](#), component D2). The selected diode must have a reverse voltage rating equal to or greater than the V_{BOOST} output voltage. The peak current rating of the diode must be greater than the maximum inductor current. The diode must also have a low forward voltage in order to reduce the power losses. Therefore, Schottky diodes are typically a good choice for the catch diode.

Also, select a diode with an appropriate power rating, because the diode conducts the output current during the off-time of the internal power switch.

9.2.3.3 BOOST Converter Application Curves

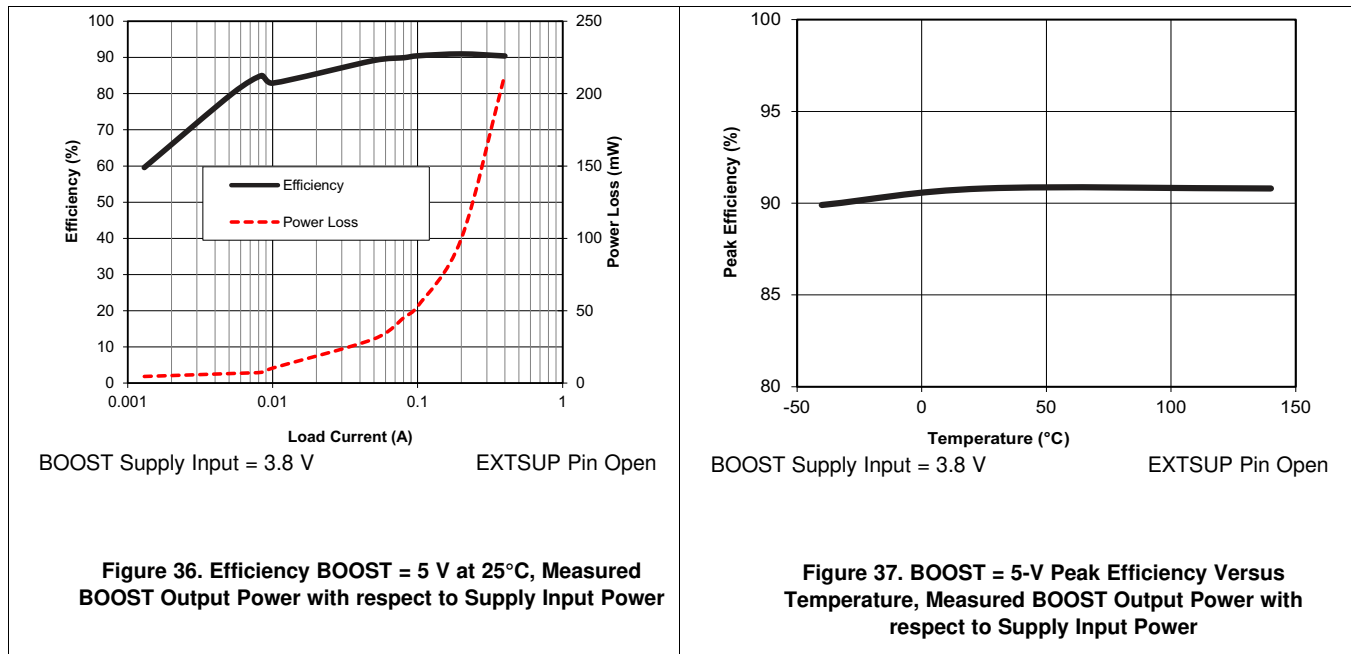

9.2.4 Linear Regulator

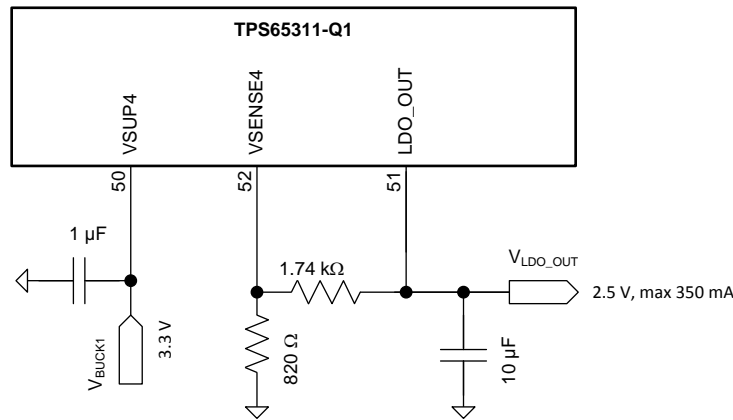

Copyright © 2017, Texas Instruments Incorporated

Figure 38. Linear Regulator Schematic

9.2.4.1 Design Requirements

For this design example, use the parameters listed in Table 6.

Table 6. Design Parameters

| DESIGN PARAMETER | EXAMPLE VALUE |
|--|---------------|
| Input voltage | 3.3 V |
| Output voltage (V _{LDO_OUT}) | 2.5 V |
| Maximum output current (I _{OUT}) | 350 mA |

9.2.4.2 Detailed Design Procedure

9.2.4.2.1 Adjusting the Output Voltage for the Linear Regulator

A resistor divider from the output node to the VSENSE4 pin sets the output voltage. TI recommends using 1% tolerance or better divider resistors. In order to get the minimum required load current of 1 mA for the linear regulator, start with a value of 820 Ω for the R_x resistor and use Equation 16 to calculate R_y (see Figure 38).

$$R_y = \frac{R_x \times (V_{LDO_OUT} - 0.8 \text{ V})}{0.8 \text{ V}} \quad (16)$$

Therefore, for the value of V_{LDO_OUT} to equal to 2.5 V, the value of R_y must be 1.74 kΩ.

9.2.4.2.2 Output Capacitance for the Linear Regulator

The linear regulator requires an external output capacitance with a value between 6 μF and 50 μF.

9.2.4.3 Linear Regulator Application Curve

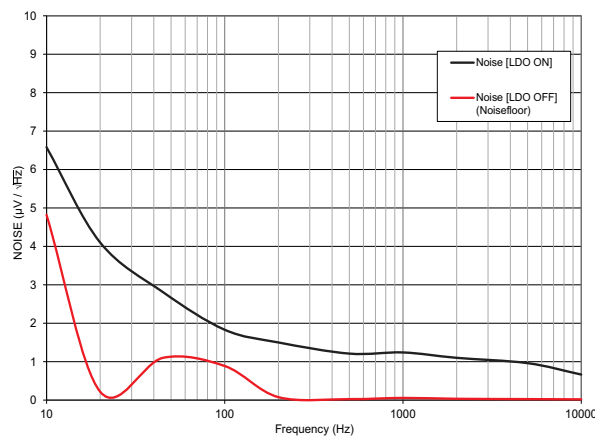

Figure 39. LDO Noise Density

10 Power Supply Recommendations

The device is designed to operate from an input voltage supply range between 4 V and 40 V (see Figure 40 for reference). This input supply must be well regulated. In case the supply voltage in the application is likely to exceed 40 V, the external PMOS protection device as explained in External Protection must be applied between VIN and VINPROT pins. Furthermore, if the supply voltage in the application is likely to reach negative voltage (for example, reverse battery), a forward diode must be placed between the VSSENSE and VIN pins. A ceramic bypass capacitor with a value of 100 μF (typical) is recommended to be placed close to the VINPROT pin. For the VIN pin, a small ceramic capacitor of typical 1 μF is recommended. Also place 1-μF (typical) bypass capacitors to the DVDD and VREF pins, and 100-nF (typical) bypass capacitors to VIO pin. Furthermore, the VREG pin requires a bypass capacitor of 2.2 μF (typical).

The BUCK1 output voltage is the recommended input supply for the BUCK2, BUCK3, and BOOST regulators. Place local, 10-μF (typical) bypass capacitors at the VSUP2 and VSUP3 pins and at the supply input of the BOOST in front of the BOOST-inductor. Also place a local, 1-μF (typical) bypass capacitor at the VSUP4 pin.

The EXTSUP pin can be used to improve efficiency. For the EXTSUP pin to improve efficiency, a voltage of more than 4.8 V is required in order to have VREG regulator supplied from EXTSUP pin. If the EXSUP pin is not used, the VINPROT pin supplies the VREG regulator. The EXTSUP pin requires a 100-nF (typical) bypass capacitor.

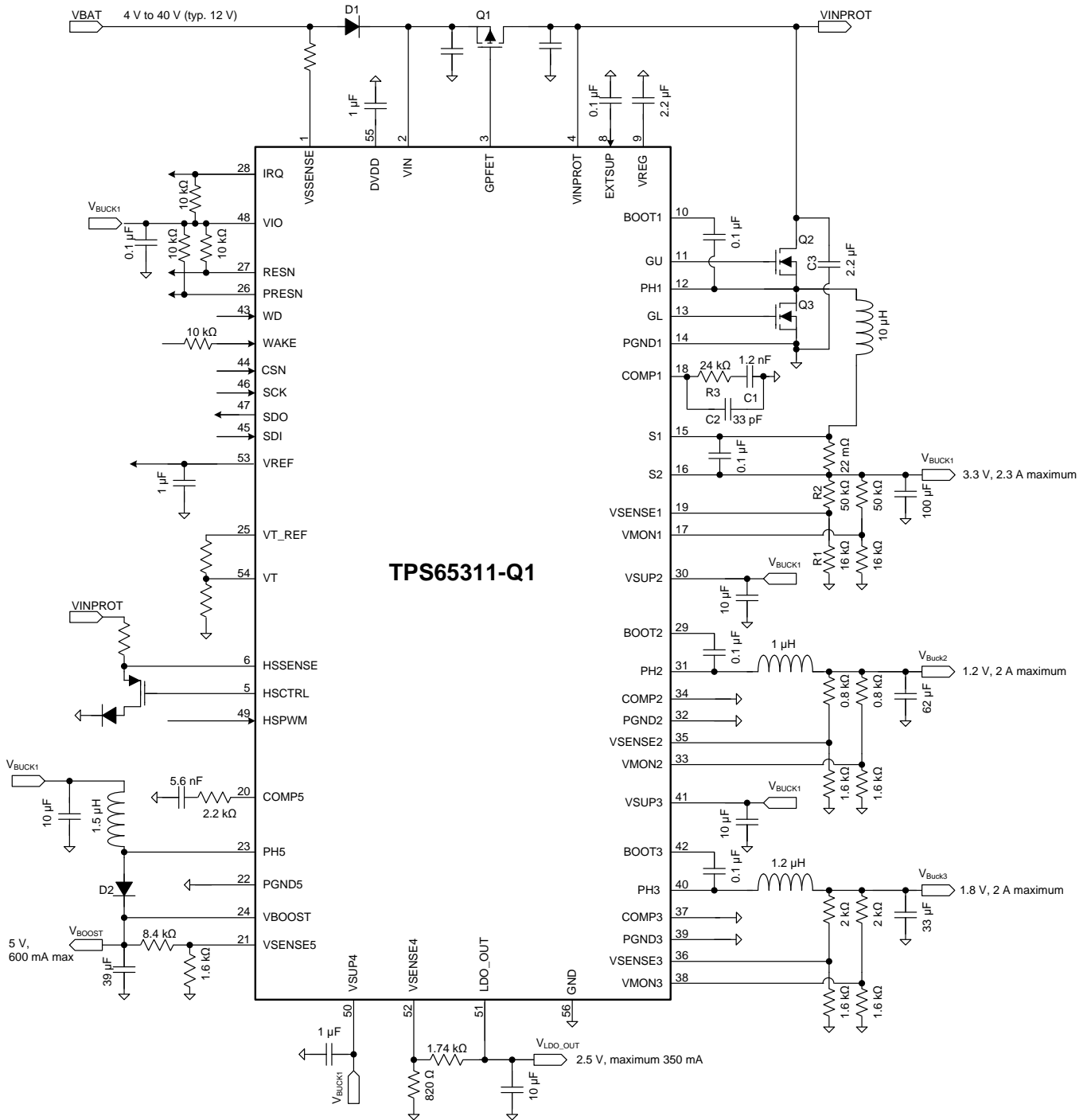

Copyright © 2017, Texas Instruments Incorporated

Figure 40. Typical Application Schematic

11 Layout

11.1 Layout Guidelines

11.1.1 Buck Controller

- Connect a local decoupling capacitor between the drain of Q3 and the source of Q2. The length of this trace loop should be short.
- The Kelvin-current sensing for the shunt resistor should have traces with minimum spacing, routed in parallel with each other. Place any filtering capacitor for noise near the S1-S2 pins.
- The resistor divider for sensing the output voltage connects between the positive pin of the output capacitor and the GND pin (IC signal ground). Do not locate these components and their traces near any switching nodes or high-current traces. The resistor divider for monitoring the output voltage is to be placed as close as possible to the sensing resistor divider, and should be connected to same traces.
- Connect the boot-strap capacitance between the PH1 and BOOT1 pins, and keep the length of these trace loops as short as possible.
- Connect the compensation network between the COMP1 pin and GND pin (IC signal ground).
- Connect a local decoupling capacitor between the VREG and PGND1 pin, and between the EXTSUP and PGND1 pin. The length of this trace loop should be short.

11.1.2 Buck Converter

- Connect a local decoupling capacitor between VSUP2 and PGND2 respectively VSUP3 and PGND3 pins. The length of this trace loop should be short.
- The resistor divider for sensing the output voltage connects between the positive pin of the output capacitor and the GND pin (IC signal ground). Do not locate these components and their traces near any switching nodes or high-current traces. The resistor divider for monitoring the output voltage is to be placed as close as possible to the sensing resistor divider, and should be connected to same traces.
- Connect the boot-strap capacitance between the PH2 and BOOT2 respectively PH3 and BOOT3 pins, and keep the length of this trace loop as short as possible.
- If COMP2 and/or COMP3 are chosen to be connected to ground, use the signal ground trace connected to GND pin for this.

11.1.3 Boost Converter

- The path formed from the input capacitor to the inductor and the PH5 pin should have short trace length. The same applies for the trace from the inductor to Schottky diode D2 to the output capacitor and the VBOOST pin. Connect the negative pin of the input capacitor and the PGND5 pin together with short trace lengths.
- The resistor divider for sensing the output voltage connects between the positive pin of the output capacitor and the GND pin (IC signal ground). Do not locate these components and their traces near any switching nodes or high-current traces.
- Connect the compensation network between the COMP5 pin and GND pin (IC signal ground).

11.1.4 Linear Regulator

- Connect a local decoupling capacitor between VSUP4 and GND (IC signal ground) pins. The length of this trace loop should be short.
- The resistor divider for sensing the output voltage connects between the positive pin of the output capacitor and the GND pin (IC signal ground). Do not locate these components and their traces near any switching nodes or high-current traces.

11.1.5 Other Considerations

- Short PGNDx and GND to the thermal pad.
- Use a star ground configuration if connecting to a non-ground plane system. Use tie-ins for the compensation-network ground, voltage-sense feedback ground, and local biasing bypass capacitor ground networks to this star ground.

11.2 Layout Example

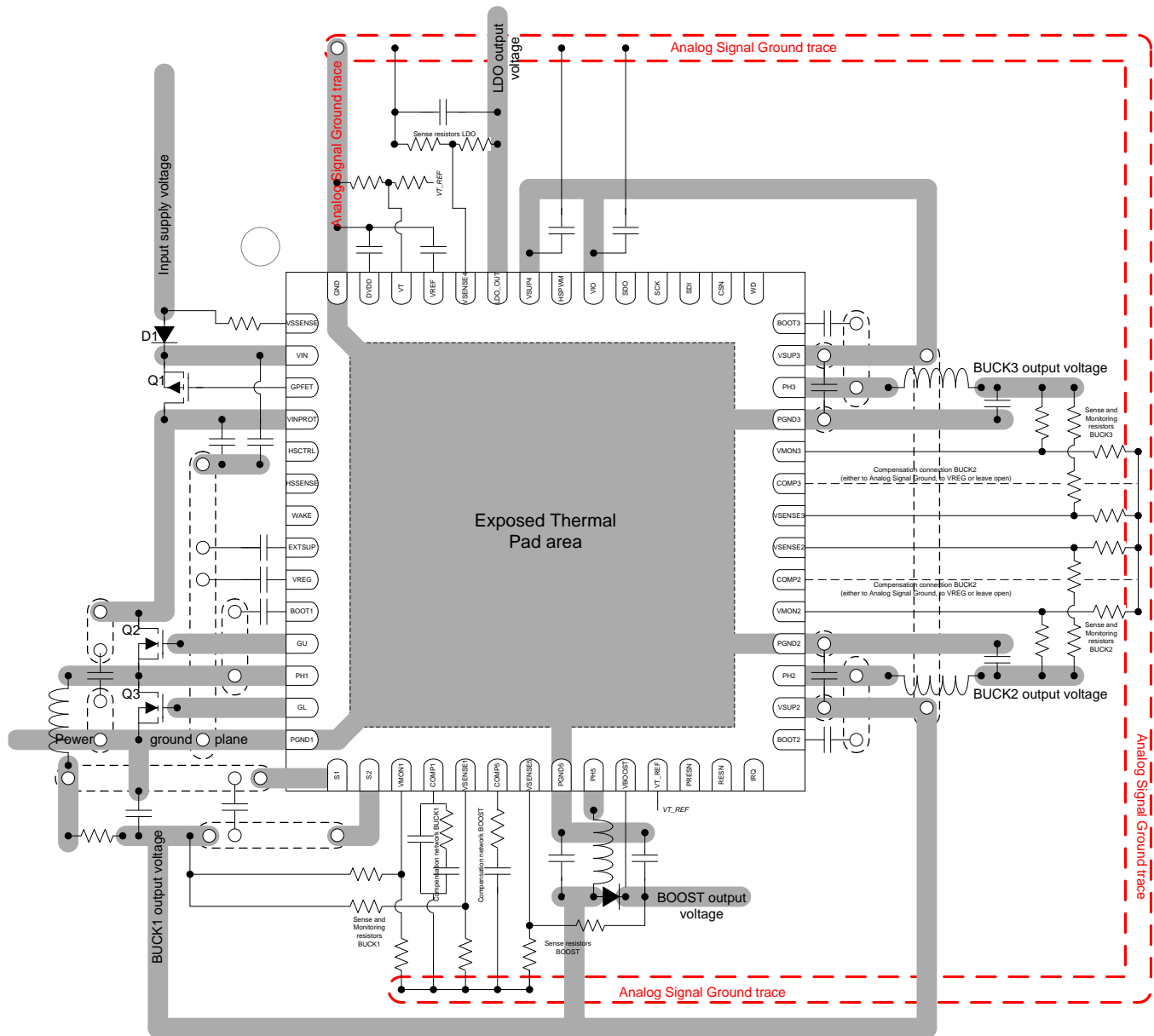

Figure 41. TPS65311-Q1 Layout Example

12 Device and Documentation Support

12.1 Documentation Support

For related documentation see the following:

- Texas Instruments, [TPS65310A-Q1 Efficiency application report](#)
- Texas Instruments, [TPS65310AEVM and TPS65311EVM Evaluation Module user's guide](#)
- Texas Instruments, [TPS65311-Q1 BUCK1 Controller DCR Current Sensing application report](#)
- Texas Instruments, [TPS65311-Q1/TPS65310A-Q1 GPFET Soft Start Using a Capacitor Between GPFET Pin and PMOS-Protection Switch Source Pin application report](#)
- Texas Instruments, [TPS65311-Q1/TPS65310A-Q1 Monitoring and Diagnostic Mechanism Definitions application report](#)

12.2 Receiving Notification of Documentation Updates

To receive notification of documentation updates, navigate to the device product folder on ti.com. In the upper right corner, click on *Alert me* to register and receive a weekly digest of any product information that has changed. For change details, review the revision history included in any revised document.

12.3 Community Resources

The following links connect to TI community resources. Linked contents are provided "AS IS" by the respective contributors. They do not constitute TI specifications and do not necessarily reflect TI's views; see TI's [Terms of Use](#).

TI E2E™ Online Community *TI's Engineer-to-Engineer (E2E) Community*. Created to foster collaboration among engineers. At e2e.ti.com, you can ask questions, share knowledge, explore ideas and help solve problems with fellow engineers.

Design Support *TI's Design Support* Quickly find helpful E2E forums along with design support tools and contact information for technical support.

12.4 Trademarks

E2E is a trademark of Texas Instruments.
All other trademarks are the property of their respective owners.

12.5 Electrostatic Discharge Caution



This integrated circuit can be damaged by ESD. Texas Instruments recommends that all integrated circuits be handled with appropriate precautions. Failure to observe proper handling and installation procedures can cause damage.

ESD damage can range from subtle performance degradation to complete device failure. Precision integrated circuits may be more susceptible to damage because very small parametric changes could cause the device not to meet its published specifications.

12.6 Glossary

[SLYZ022](#) — *TI Glossary*.

This glossary lists and explains terms, acronyms, and definitions.

13 Mechanical, Packaging, and Orderable Information

The following pages include mechanical packaging and orderable information. This information is the most current data available for the designated devices. This data is subject to change without notice and revision of this document. For browser-based versions of this data sheet, refer to the left-hand navigation.

PACKAGING INFORMATION

| Orderable Device | Status (1) | Package Type | Package Drawing | Pins | Package Qty | Eco Plan (2) | Lead finish/ Ball material (6) | MSL Peak Temp (3) | Op Temp (°C) | Device Marking (4/5) | Samples |
|------------------|---------------|--------------|--------------------|------|----------------|-----------------|--------------------------------------|----------------------|--------------|-------------------------|---------|
| TPS65311QRVJRQ1 | ACTIVE | VQFN | RVJ | 56 | 2000 | RoHS & Green | NIPDAU | Level-3-260C-168 HR | -40 to 125 | TPS65311 | Samples |

(1) The marketing status values are defined as follows:

ACTIVE: Product device recommended for new designs.

LIFEBUY: TI has announced that the device will be discontinued, and a lifetime-buy period is in effect.

NRND: Not recommended for new designs. Device is in production to support existing customers, but TI does not recommend using this part in a new design.

PREVIEW: Device has been announced but is not in production. Samples may or may not be available.

OBSOLETE: TI has discontinued the production of the device.

(2) **RoHS:** TI defines "RoHS" to mean semiconductor products that are compliant with the current EU RoHS requirements for all 10 RoHS substances, including the requirement that RoHS substance do not exceed 0.1% by weight in homogeneous materials. Where designed to be soldered at high temperatures, "RoHS" products are suitable for use in specified lead-free processes. TI may reference these types of products as "Pb-Free".

RoHS Exempt: TI defines "RoHS Exempt" to mean products that contain lead but are compliant with EU RoHS pursuant to a specific EU RoHS exemption.

Green: TI defines "Green" to mean the content of Chlorine (Cl) and Bromine (Br) based flame retardants meet JS709B low halogen requirements of <=1000ppm threshold. Antimony trioxide based flame retardants must also meet the <=1000ppm threshold requirement.

(3) MSL, Peak Temp. - The Moisture Sensitivity Level rating according to the JEDEC industry standard classifications, and peak solder temperature.

(4) There may be additional marking, which relates to the logo, the lot trace code information, or the environmental category on the device.

(5) Multiple Device Markings will be inside parentheses. Only one Device Marking contained in parentheses and separated by a "-" will appear on a device. If a line is indented then it is a continuation of the previous line and the two combined represent the entire Device Marking for that device.

(6) Lead finish/Ball material - Orderable Devices may have multiple material finish options. Finish options are separated by a vertical ruled line. Lead finish/Ball material values may wrap to two lines if the finish value exceeds the maximum column width.

Important Information and Disclaimer: The information provided on this page represents TI's knowledge and belief as of the date that it is provided. TI bases its knowledge and belief on information provided by third parties, and makes no representation or warranty as to the accuracy of such information. Efforts are underway to better integrate information from third parties. TI has taken and continues to take reasonable steps to provide representative and accurate information but may not have conducted destructive testing or chemical analysis on incoming materials and chemicals. TI and TI suppliers consider certain information to be proprietary, and thus CAS numbers and other limited information may not be available for release.

In no event shall TI's liability arising out of such information exceed the total purchase price of the TI part(s) at issue in this document sold by TI to Customer on an annual basis.

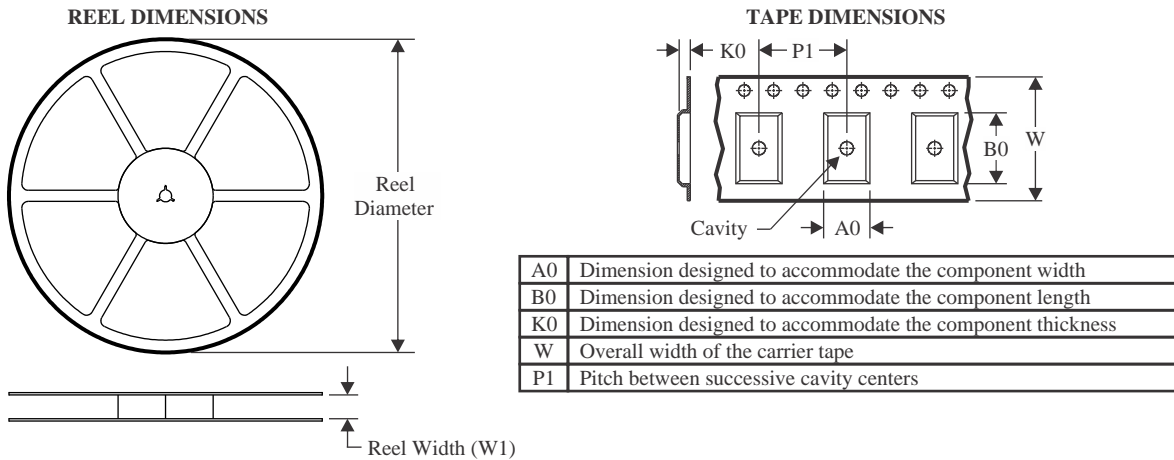
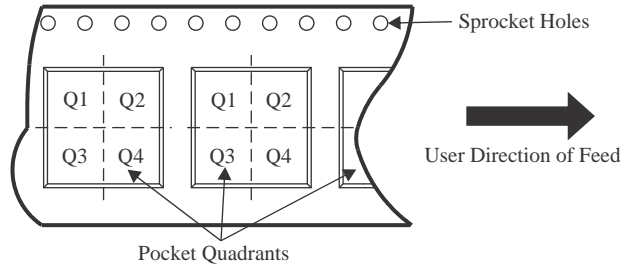
TAPE AND REEL INFORMATION

QUADRANT ASSIGNMENTS FOR PIN 1 ORIENTATION IN TAPE

*All dimensions are nominal

| Device | Package Type | Package Drawing | Pins | SPQ | Reel Diameter (mm) | Reel Width W1 (mm) | A0 (mm) | B0 (mm) | K0 (mm) | P1 (mm) | W (mm) | Pin1 Quadrant |
|-----------------|--------------|-----------------|------|------|--------------------|--------------------|---------|---------|---------|---------|--------|---------------|
| TPS65311QRVJRQ1 | VQFN | RVJ | 56 | 2000 | 330.0 | 16.4 | 8.3 | 8.3 | 1.1 | 12.0 | 16.0 | Q2 |

TAPE AND REEL BOX DIMENSIONS

*All dimensions are nominal

| Device | Package Type | Package Drawing | Pins | SPQ | Length (mm) | Width (mm) | Height (mm) |
|-----------------|--------------|-----------------|------|------|-------------|------------|-------------|
| TPS65311QRVJRQ1 | VQFN | RVJ | 56 | 2000 | 367.0 | 367.0 | 35.0 |

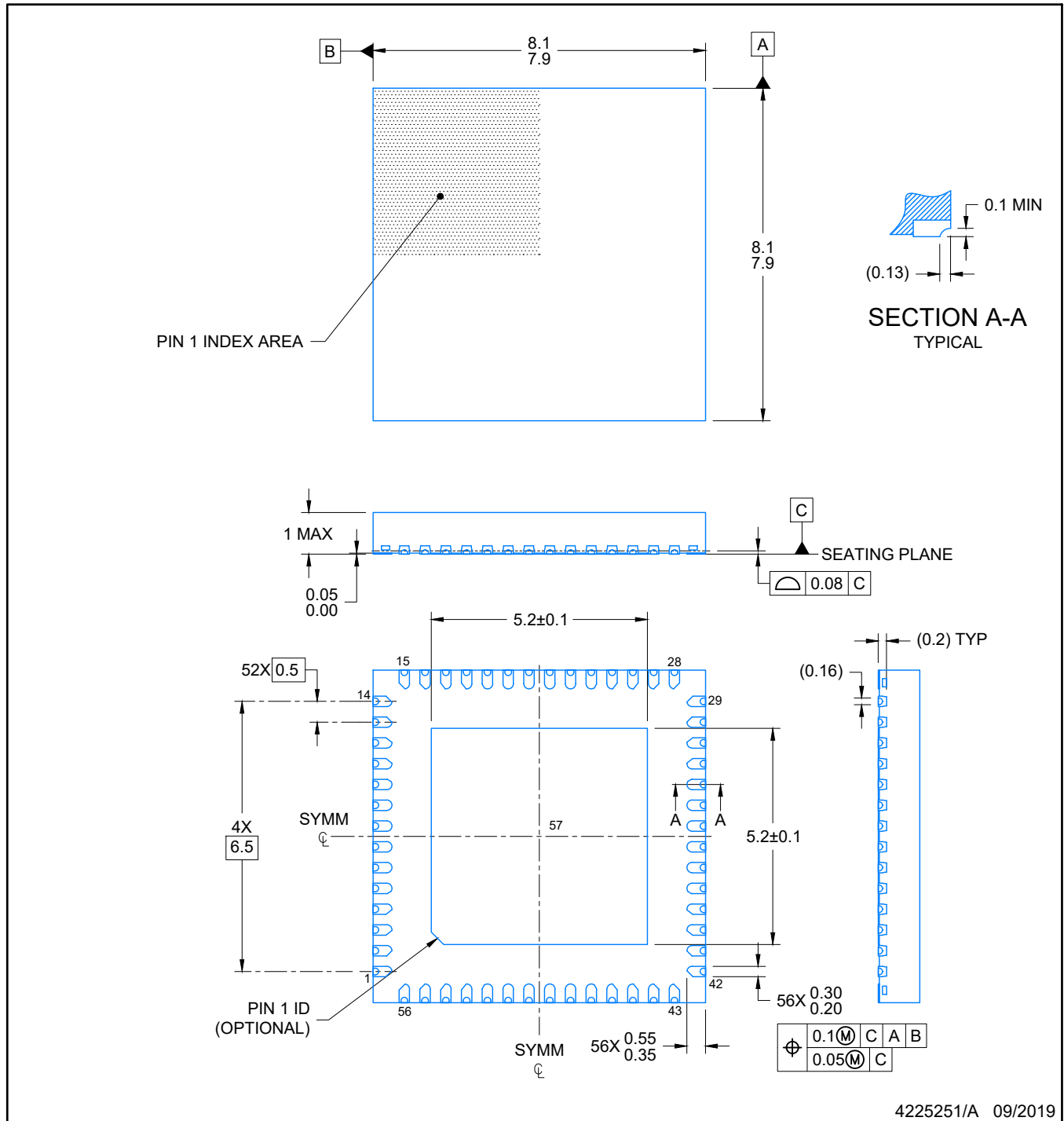

NOTES:

1. All linear dimensions are in millimeters. Any dimensions in parenthesis are for reference only. Dimensioning and tolerancing per ASME Y14.5M.
2. This drawing is subject to change without notice.
3. The package thermal pad must be soldered to the printed circuit board for optimal thermal and mechanical performance.

EXAMPLE BOARD LAYOUT

RVJ0056A

VQFN - 1 mm max height

PLASTIC QUAD FLATPACK- NO LEAD

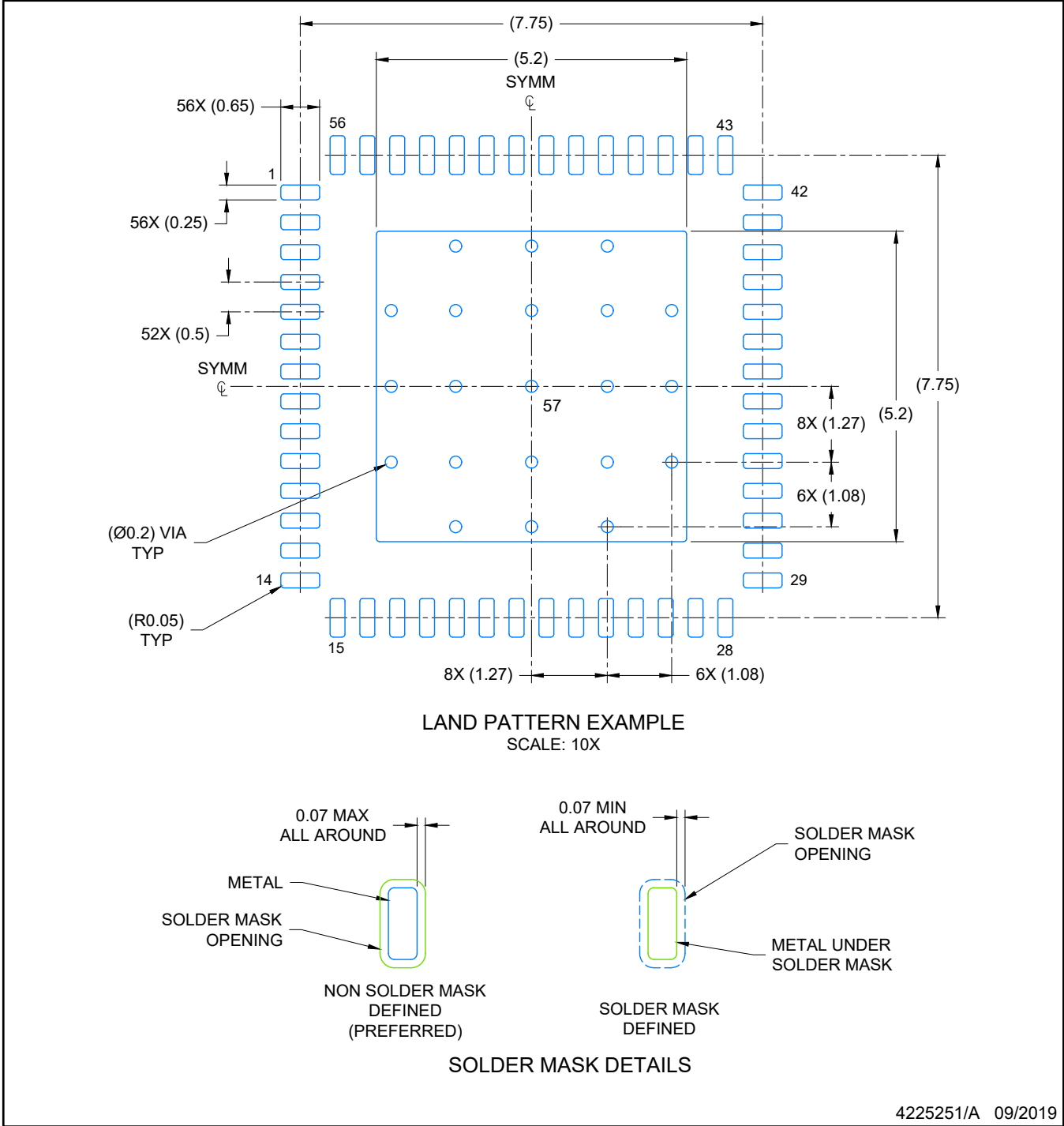

NOTES: (continued)

- 4. This package is designed to be soldered to a thermal pad on the board. For more information, see Texas Instruments literature number SLUA271 (www.ti.com/lit/slua271).
- 5. Vias are optional depending on application, refer to device data sheet. If any vias are implemented, refer to their locations shown on this view. It is recommended that vias under paste be filled, plugged or tented.

EXAMPLE STENCIL DESIGN

RVJ0056A

VQFN - 1 mm max height

PLASTIC QUAD FLATPACK- NO LEAD

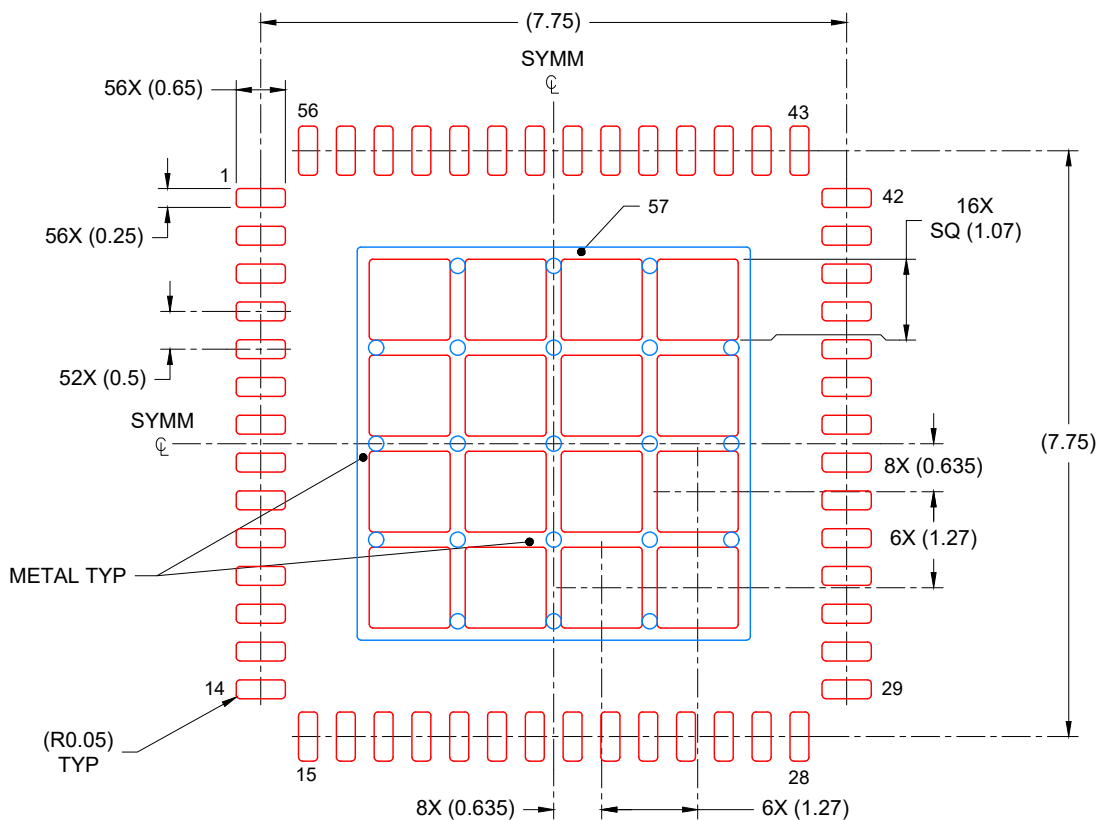

SOLDER PASTE EXAMPLE
BASED ON 0.125 mm THICK STENCIL

EXPOSED PAD
67% PRINTED COVERAGE BY AREA
SCALE: 10X

4225251/A 09/2019

NOTES: (continued)

6. Laser cutting apertures with trapezoidal walls and rounded corners may offer better paste release. IPC-7525 may have alternate design recommendations.

IMPORTANT NOTICE AND DISCLAIMER

TI PROVIDES TECHNICAL AND RELIABILITY DATA (INCLUDING DATA SHEETS), DESIGN RESOURCES (INCLUDING REFERENCE DESIGNS), APPLICATION OR OTHER DESIGN ADVICE, WEB TOOLS, SAFETY INFORMATION, AND OTHER RESOURCES "AS IS" AND WITH ALL FAULTS, AND DISCLAIMS ALL WARRANTIES, EXPRESS AND IMPLIED, INCLUDING WITHOUT LIMITATION ANY IMPLIED WARRANTIES OF MERCHANTABILITY, FITNESS FOR A PARTICULAR PURPOSE OR NON-INFRINGEMENT OF THIRD PARTY INTELLECTUAL PROPERTY RIGHTS.

These resources are intended for skilled developers designing with TI products. You are solely responsible for (1) selecting the appropriate TI products for your application, (2) designing, validating and testing your application, and (3) ensuring your application meets applicable standards, and any other safety, security, regulatory or other requirements.

These resources are subject to change without notice. TI grants you permission to use these resources only for development of an application that uses the TI products described in the resource. Other reproduction and display of these resources is prohibited. No license is granted to any other TI intellectual property right or to any third party intellectual property right. TI disclaims responsibility for, and you will fully indemnify TI and its representatives against, any claims, damages, costs, losses, and liabilities arising out of your use of these resources.

TI's products are provided subject to [TI's Terms of Sale](#) or other applicable terms available either on [ti.com](https://www.ti.com) or provided in conjunction with such TI products. TI's provision of these resources does not expand or otherwise alter TI's applicable warranties or warranty disclaimers for TI products.

TI objects to and rejects any additional or different terms you may have proposed.

Mailing Address: Texas Instruments, Post Office Box 655303, Dallas, Texas 75265
Copyright © 2023, Texas Instruments Incorporated