

REVISION E

DO NOT SCALE FROM THIS PRINT

- NOTES:
1. MINIMUM PUSHOUT FORCE: 1.2N
 2. PARTS TO BE PACKAGED IN TAPE & REEL.
 3. SEE SHT 2 FOR PROCESSING INFORMATION
 4. ORDERS WILL BE PACKAGED ACCORDING TO THE SAMTEC PACKAGING EFFICIENCY STANDARDS [SPES] FOUND ON WWW.SAMTEC.COM.
 5. ATTACH LABEL-4X2 TO EACH REEL.

DESIGNED AND DIMENSIONED IN MILLIMETERS[INCHES]
ALL DIMENSIONS REFERENCE EXCEPT AS SHOWN

SOME CENTER FEATURES NOT SHOWN FOR CLARITY

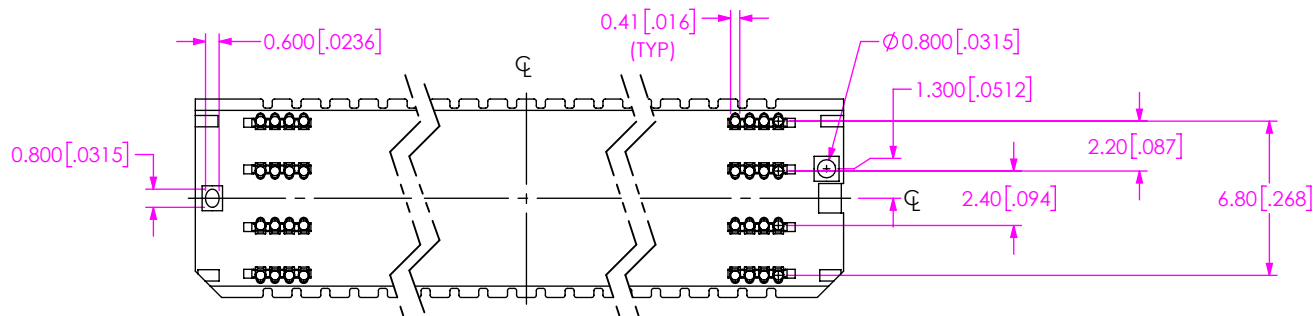
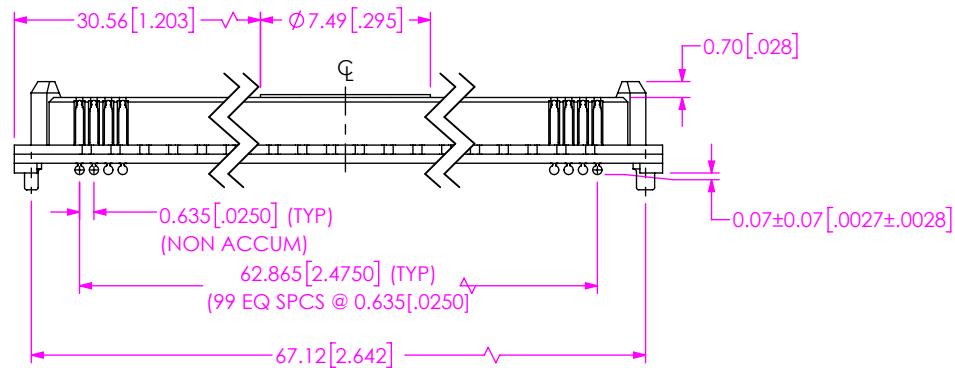
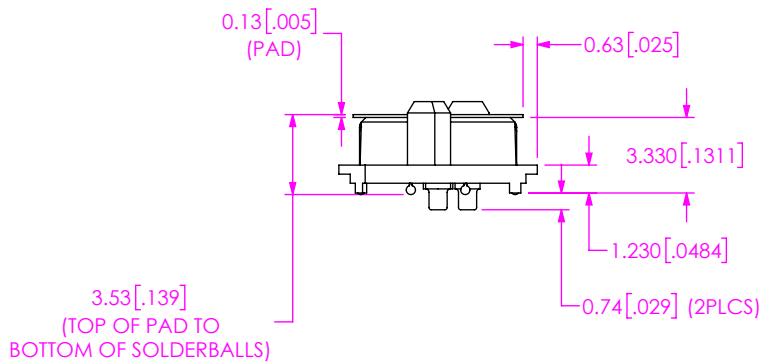
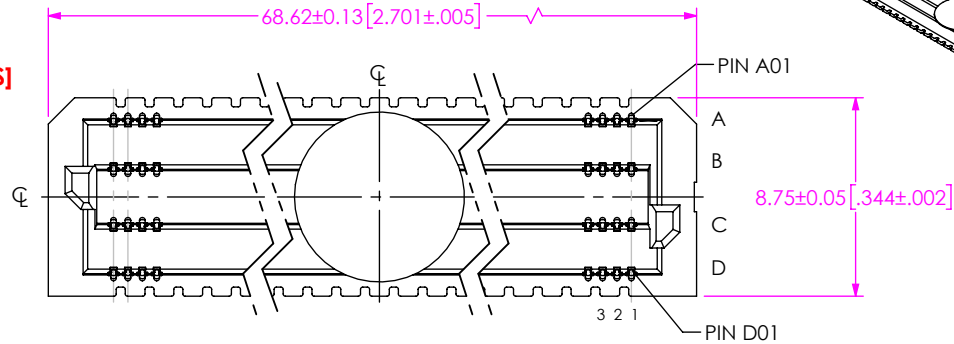
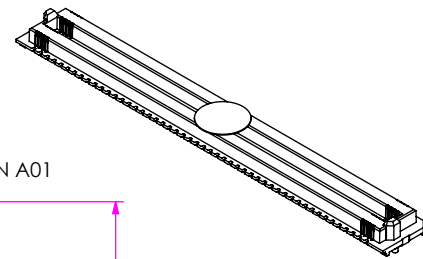

FIG 1
(ASP-214802-01 SHOWN)

PROPRIETARY NOTE
THIS DOCUMENT CONTAINS CONFIDENTIAL AND PROPRIETARY INFORMATION AND ALL DESIGN, MANUFACTURING, REPRODUCTION, USE, PATENT RIGHTS AND SALES RIGHTS ARE EXPRESSLY RESERVED BY SAMTEC, INC. THIS DOCUMENT SHALL NOT BE DISCLOSED, IN WHOLE OR PART, TO ANY UNAUTHORIZED PERSON OR ENTITY NOR REPRODUCED, TRANSFERRED OR INCORPORATED IN ANY OTHER PROJECT IN ANY MANNER WITHOUT THE EXPRESS WRITTEN CONSENT OF SAMTEC, INC.

DO NOT SCALE DRAWING SHEET SCALE: 3:1

MATERIAL:
INSULATOR: LCP, COLOR: NATURAL
TERMINAL: COPPER ALLOY

PLATING:
CONTACT AREA: .00010" GOLD OVER .000050" NICKEL
REMAINDER: .000200" REF TIN OVER .000050" NICKEL

F:\DWG\MISC\MKTG\ASP-214802-01-MKT.SLDDRW



520 PARK EAST BLVD, NEW ALBANY, IN 47150
PHONE: 812-944-6733 FAX: 812-948-5047
e-Mail info@SAMTEC.com code 53322

DESCRIPTION:
CUSTOM COM HPC MALE ASSEMBLY

DWG. NO. ASP-214802-01

BY: R CURRY 10/17/2019 SHEET 1 OF 8

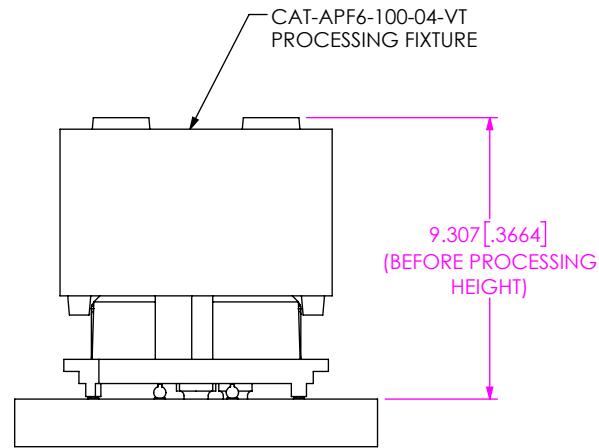

PROCESSING VIEW
 DIMENSION INDICATES CONNECTOR/FIXTURE HEIGHT ON PCB
 TO GUARANTEE ENOUGH REFLOW OVEN WORKING SPACE.
 DIMENSION, PCB THICKNESS, AND THE HEIGHT OF THE COMPONENTS
 ON THE OTHER SIDE OF THE BOARD NEED TO BE CONSIDERED.

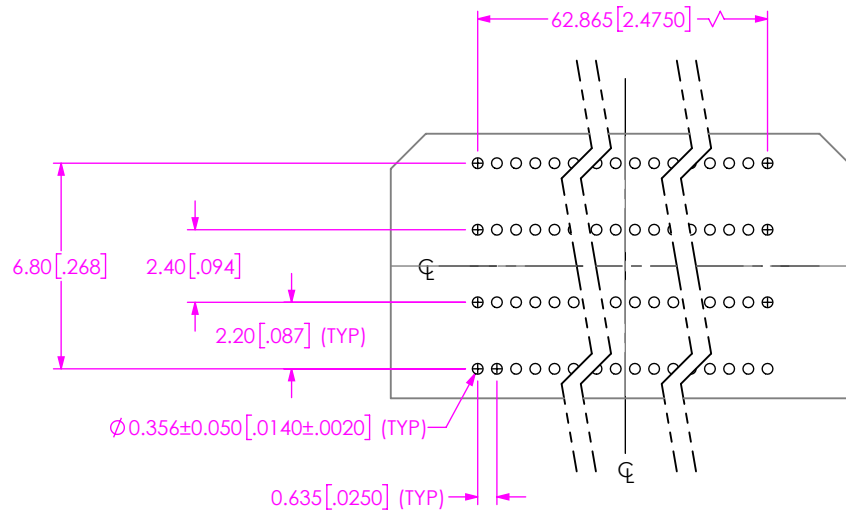

RECOMMENDED STENCIL LAYOUT
 ALL DIMENSIONS SYMMETRIC ABOUT CENTERLINE
 (STENCIL TO BE 0.125 [.0050] THICK)

PROPRIETARY NOTE

THIS DOCUMENT CONTAINS CONFIDENTIAL AND PROPRIETARY INFORMATION AND ALL DESIGN, MANUFACTURING, REPRODUCTION, USE, PATENT RIGHTS AND SALES RIGHTS ARE EXPRESSLY RESERVED BY SAMTEC, INC. THIS DOCUMENT SHALL NOT BE DISCLOSED, IN WHOLE OR PART, TO ANY UNAUTHORIZED PERSON OR ENTITY NOR REPRODUCED, TRANSFERRED OR INCORPORATED IN ANY OTHER PROJECT IN ANY MANNER WITHOUT THE EXPRESS WRITTEN CONSENT OF SAMTEC, INC.



520 PARK EAST BLVD, NEW ALBANY, IN 47150
 PHONE: 812-944-6733 FAX: 812-948-5047
 e-Mail info@SAMTEC.com code 55322

SHEET SCALE: 1:1

DESCRIPTION:
 CUSTOM COM HPC MALE ASSEMBLY

DWG. NO.
 ASP-214802-01

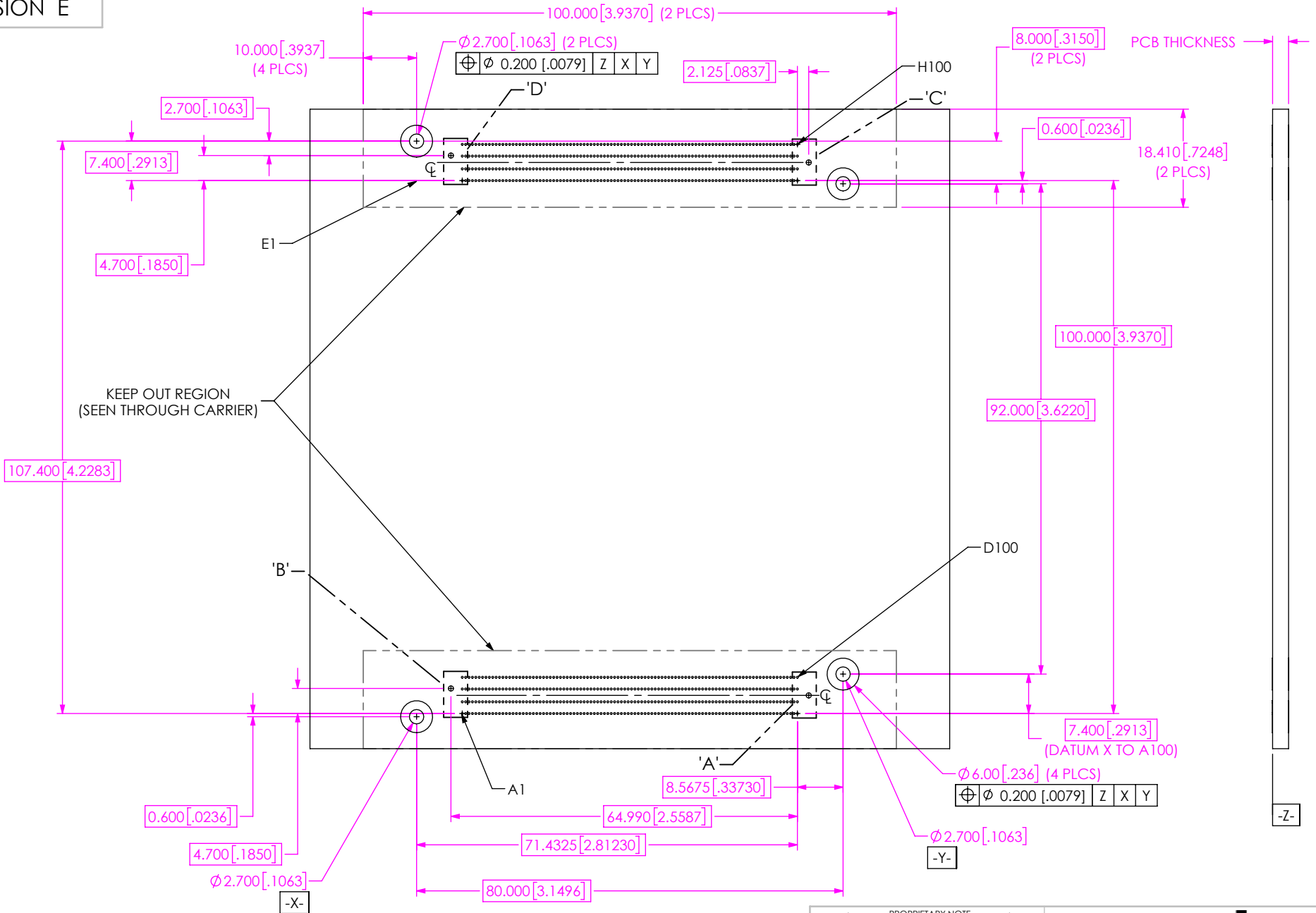
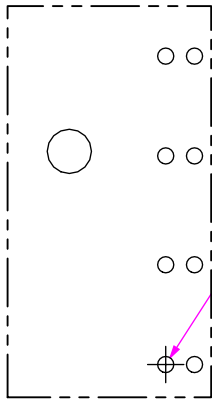

FIG 2
 (RECOMMENDED ASP-214802-01)
 (LAYOUT FOR COM-HPC® MODULE SIZE A & B)

<p>PROPRIETARY NOTE</p> <p>THIS DOCUMENT CONTAINS CONFIDENTIAL AND PROPRIETARY INFORMATION AND ALL DESIGN, MANUFACTURING, REPRODUCTION, USE, PATENT RIGHTS AND SALES RIGHTS ARE EXPRESSLY RESERVED BY SAMTEC, INC. THIS DOCUMENT SHALL NOT BE DISCLOSED, IN WHOLE OR PART, TO ANY UNAUTHORIZED PERSON OR ENTITY NOR REPRODUCED, TRANSFERRED OR INCORPORATED IN ANY OTHER PROJECT IN ANY MANNER WITHOUT THE EXPRESS WRITTEN CONSENT OF SAMTEC, INC.</p>	<p>samtec</p> <p>520 PARK EAST BLVD., NEW ALBANY, IN 47150 PHONE: 812-944-6733 FAX: 812-948-5047 e-Mail: info@SAMTEC.com code 55322</p>
<p>SHEET SCALE: 1:1</p>	<p>DESCRIPTION: CUSTOM COM HPC MALE ASSEMBLY</p>
<p>F:\DWG\MISC\MKTG\ASP-214802-01-MKT.SLDRW</p>	<p>DWG. NO. ASP-214802-01</p> <p>BY: R CURRY 10/17/2019 SHEET 3 OF 8</p>



$\varnothing 0.356 \pm 0.030 [0.140 \pm 0.012]$

\varnothing	0.100	[.0039]	Z	U	V
\varnothing	0.200	[.0079]	Z	S	T
-T-					

DETAIL 'D'
SCALE 6 : 1

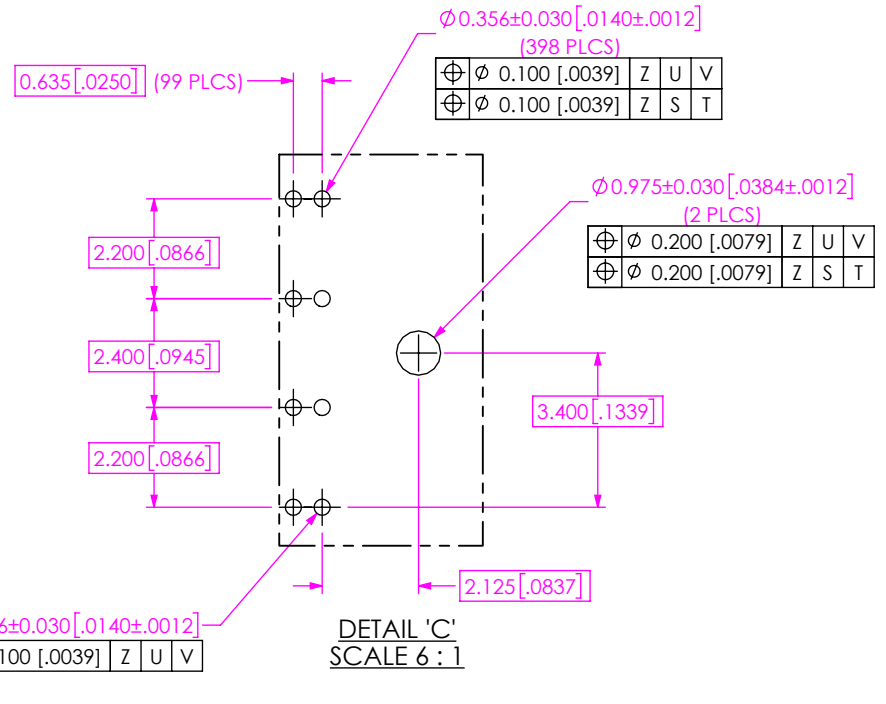

$\varnothing 0.356 \pm 0.030 [0.140 \pm 0.012]$

\varnothing	0.100	[.0039]	Z	U	V
-S-					

DETAIL 'C'
SCALE 6 : 1

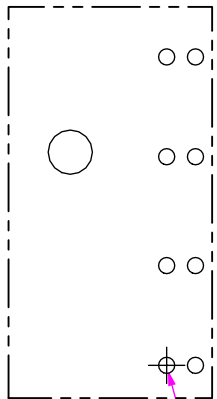

$\varnothing 0.356 \pm 0.030 [0.140 \pm 0.012]$

\varnothing	0.200	[.0079]	Z	X	Y
\varnothing	0.100	[.0039]	Z	U	
-V-					

DETAIL 'B'
SCALE 6 : 1

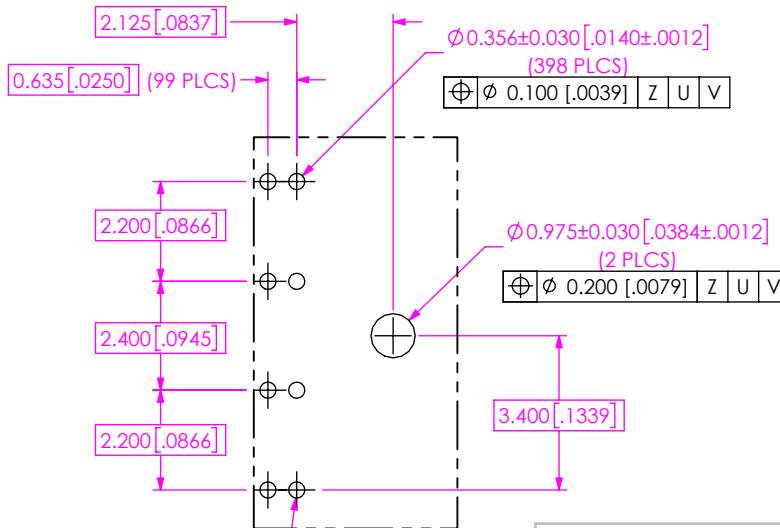

$\varnothing 0.356 \pm 0.030 [0.140 \pm 0.012]$

\varnothing	0.200	[.0079]	Z	X	Y
-U-					

DETAIL 'A'
SCALE 6 : 1

PROPRIETARY NOTE
 THIS DOCUMENT CONTAINS CONFIDENTIAL AND PROPRIETARY INFORMATION AND ALL DESIGN, MANUFACTURING, REPRODUCTION, USE, PATENT RIGHTS AND SALES RIGHTS ARE EXPRESSLY RESERVED BY SAMTEC, INC. THIS DOCUMENT SHALL NOT BE DISCLOSED, IN WHOLE OR PART, TO ANY UNAUTHORIZED PERSON OR ENTITY NOR REPRODUCED, TRANSFERRED OR INCORPORATED IN ANY OTHER PROJECT IN ANY MANNER WITHOUT THE EXPRESS WRITTEN CONSENT OF SAMTEC, INC.

SHEET SCALE: 1:1

F:\DWG\MISC\MKTG\ASP-214802-01-MKT.SLDDRW

samtec
 520 PARK EAST BLVD, NEW ALBANY, IN 47150
 PHONE: 812-944-6733 FAX: 812-948-5047
 e-Mail: info@SAMTEC.com code 55322

DESCRIPTION:
 CUSTOM COM HPC MALE ASSEMBLY

DWG. NO.
ASP-214802-01

BY: R CURRY 10/17/2019 SHEET 4 OF 8

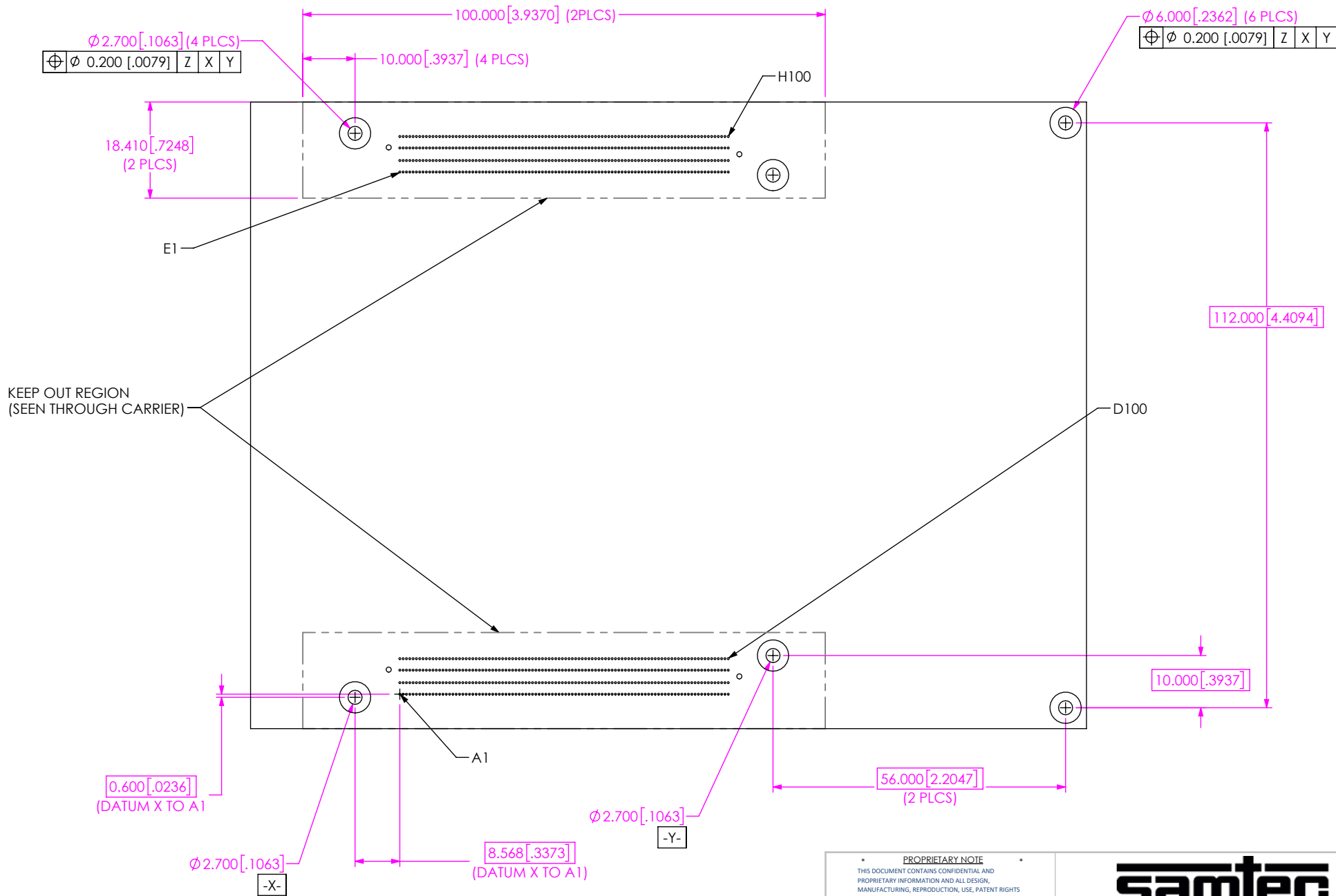



FIG 3
 (RECOMMENDED ASP-214802-01)
 (SAME AS FIG 2, EXCEPT AS SHOWN)
 (LAYOUT FOR COM-HPC® MODULE SIZE C)

<p>PROPRIETARY NOTE</p> <p>THIS DOCUMENT CONTAINS CONFIDENTIAL AND PROPRIETARY INFORMATION AND ALL DESIGN, MANUFACTURING, REPRODUCTION, USE, PATENT RIGHTS AND SALES RIGHTS ARE EXPRESSLY RESERVED BY SAMTEC, INC. THIS DOCUMENT SHALL NOT BE DISCLOSED, IN WHOLE OR PART, TO ANY UNAUTHORIZED PERSON OR ENTITY NOR REPRODUCED, TRANSFERRED OR INCORPORATED IN ANY OTHER PROJECT IN ANY MANNER WITHOUT THE EXPRESS WRITTEN CONSENT OF SAMTEC, INC.</p>	 520 PARK EAST BLVD. NEW ALBANY, IN 47150 PHONE: 812-944-6733 FAX: 812-948-5047 e-Mail: info@SAMTEC.com code 55322	
	SHEET SCALE: 1:1	DESCRIPTION: CUSTOM COM HPC MALE ASSEMBLY
DWG. NO.		ASP-214802-01
BY: R CURRY		10/17/2019
F:\DWG\MISC\MKTG\ASP-214802-01-MKT.SLDRW		SHEET 5 OF 8

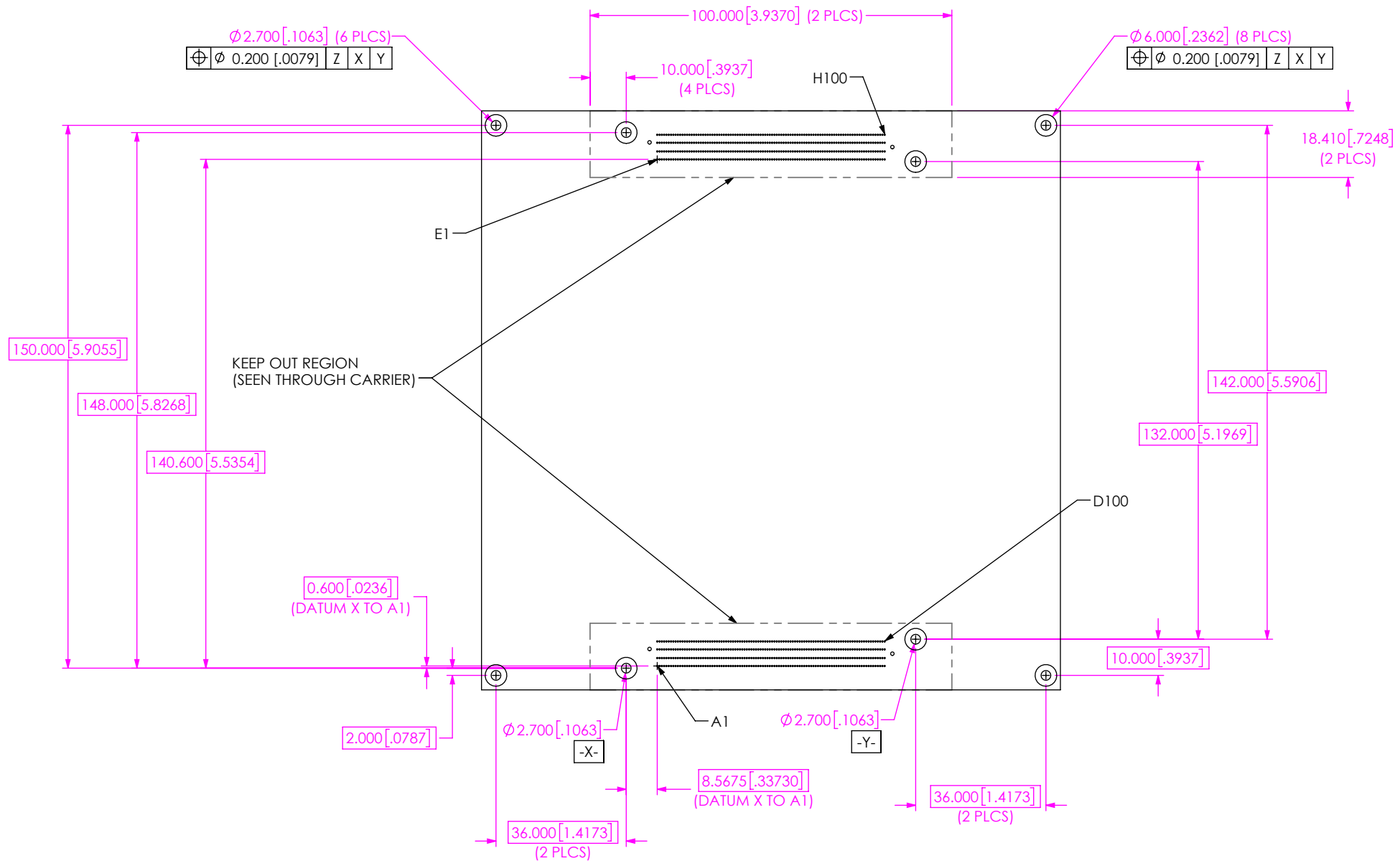

FIG 4
 (RECOMMENDED ASP-214802-01)
 (SAME AS FIG 2, EXCEPT AS SHOWN)
 (LAYOUT FOR COM-HPC® MODULE SIZE D)

<p>PROPRIETARY NOTE</p> <p>THIS DOCUMENT CONTAINS CONFIDENTIAL AND PROPRIETARY INFORMATION AND ALL DESIGN, MANUFACTURING, REPRODUCTION, USE, PATENT RIGHTS AND SALES RIGHTS ARE EXPRESSLY RESERVED BY SAMTEC, INC. THIS DOCUMENT SHALL NOT BE DISCLOSED, IN WHOLE OR PART, TO ANY UNAUTHORIZED PERSON OR ENTITY NOR REPRODUCED, TRANSFERRED OR INCORPORATED IN ANY OTHER PROJECT IN ANY MANNER WITHOUT THE EXPRESS WRITTEN CONSENT OF SAMTEC, INC.</p>	<p>samtec</p> <p>520 PARK EAST BLVD., NEW ALBANY, IN 47150 PHONE: 812-944-6733 FAX: 812-948-5047 e-Mail info@SAMTEC.com code 55322</p>		
	<p>DESCRIPTION: CUSTOM COM HPC MALE ASSEMBLY</p>	<p>DWG. NO. ASP-214802-01</p>	
<p>SHEET SCALE: 1:1</p>	<p>BY: R CURRY</p>	<p>10/17/2019</p>	<p>SHEET 6 OF 8</p>

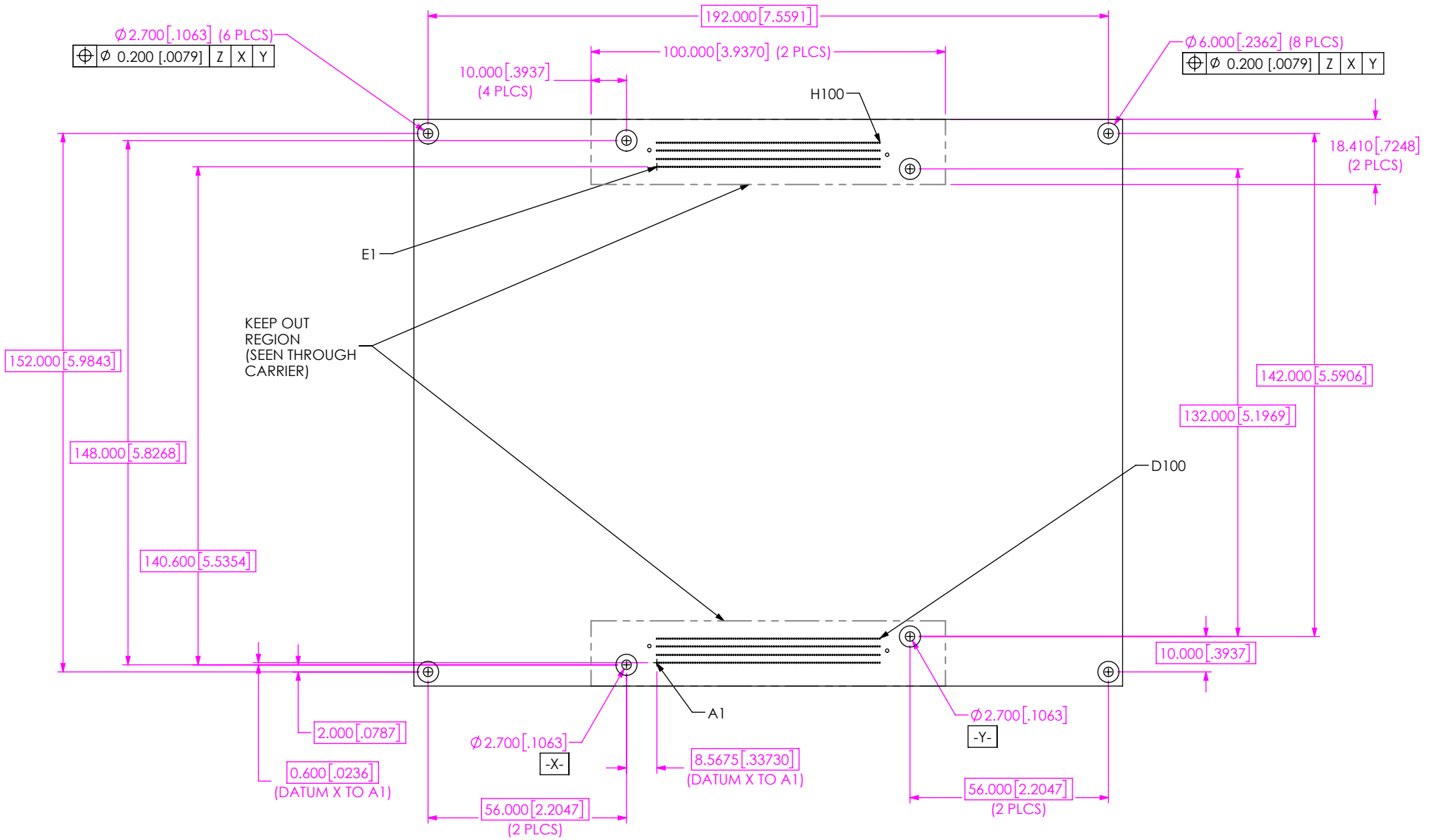

FIG 5
 (RECOMMENDED ASP-214802-01)
 (SAME AS FIG 2, EXCEPT AS SHOWN)
 (LAYOUT FOR COM-HPC® MODULE SIZE E)

PROPRIETARY NOTE
 * THIS DOCUMENT CONTAINS CONFIDENTIAL AND PROPRIETARY INFORMATION AND ALL DESIGN, MANUFACTURING, REPRODUCTION, USE, PATENT RIGHTS AND SALES RIGHTS ARE EXPRESSLY RESERVED BY SAMTEC, INC. THIS DOCUMENT SHALL NOT BE DISCLOSED, IN WHOLE OR PART, TO ANY UNAUTHORIZED PERSON OR ENTITY NOR REPRODUCED, TRANSFERRED OR INCORPORATED IN ANY OTHER PROJECT IN ANY MANNER WITHOUT THE EXPRESS WRITTEN CONSENT OF SAMTEC, INC.



520 PARK EAST BLVD., NEW ALBANY, IN 47150
 PHONE: 812-944-6733 FAX: 812-948-5047
 e-Mail info@SAMTEC.com code 55322

SHEET SCALE: 1:1

DESCRIPTION:
 CUSTOM COM HPC MALE ASSEMBLY

DWG. NO.
ASP-214802-01

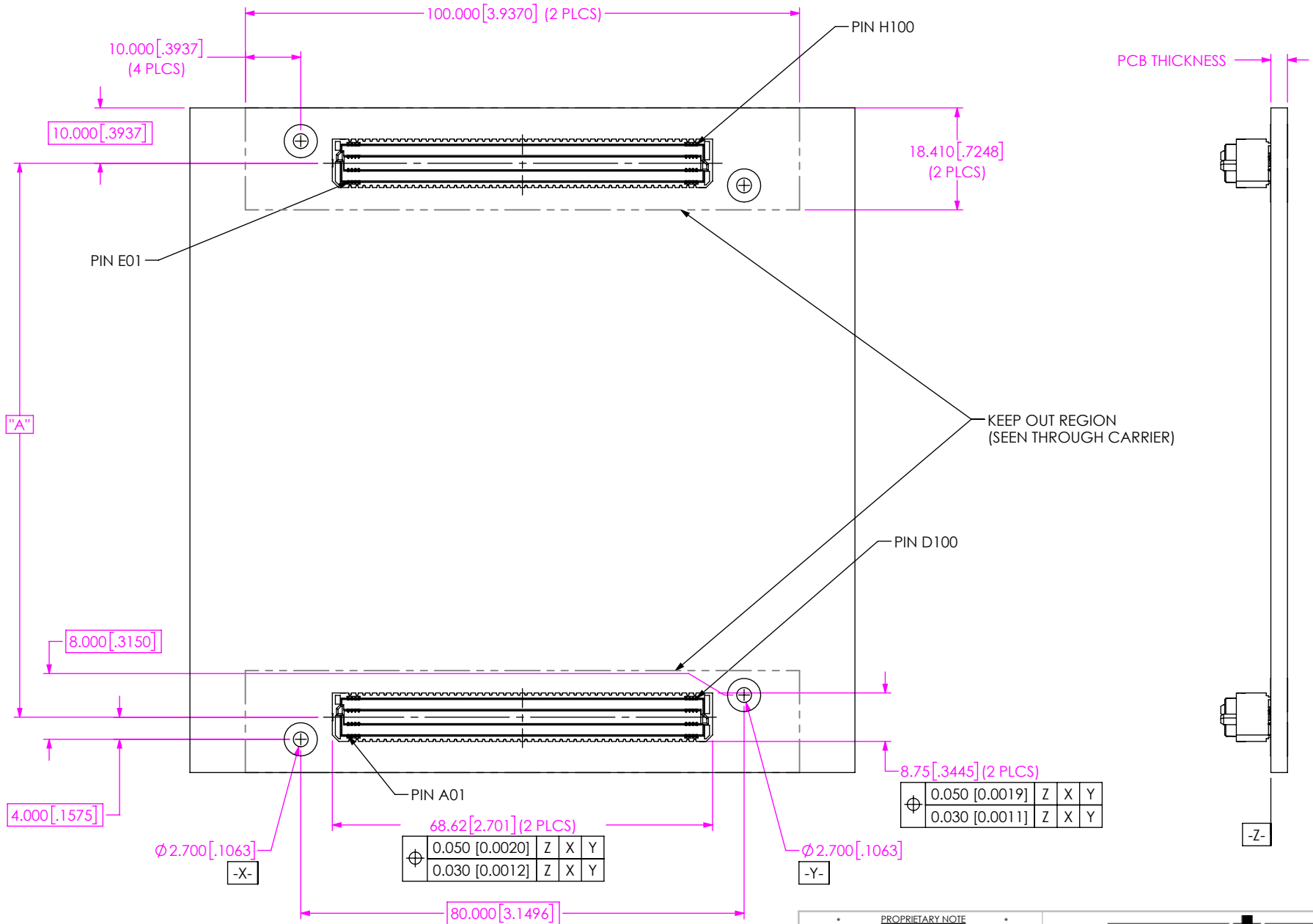

FIG 6
COM-HPC® ASSEMBLY APPLICATION
(RECOMMENDED ASP-214802-01 LAYOUT FOR COM-HPC®)

TABLE 1	
COM-HPC® MODULE	"A"
SIZE A	100.000 [3.937]
SIZE B	100.000 [3.937]
SIZE C	100.000 [3.937]
SIZE D	140.000 [5.512]
SIZE E	140.000 [5.512]

⊕	0.050 [0.0019]	Z	X	Y
	0.030 [0.0011]	Z	X	Y

⊕	0.050 [0.0020]	Z	X	Y
	0.030 [0.0012]	Z	X	Y

PROPRIETARY NOTE
 THIS DOCUMENT CONTAINS CONFIDENTIAL AND PROPRIETARY INFORMATION AND ALL DESIGN, MANUFACTURING, REPRODUCTION, USE, PATENT RIGHTS AND SALES RIGHTS ARE EXPRESSLY RESERVED BY SAMTEC, INC. THIS DOCUMENT SHALL NOT BE DISCLOSED, IN WHOLE OR PART, TO ANY UNAUTHORIZED PERSON OR ENTITY NOR REPRODUCED, TRANSFERRED OR INCORPORATED IN ANY OTHER PROJECT IN ANY MANNER WITHOUT THE EXPRESS WRITTEN CONSENT OF SAMTEC, INC.

SHEET SCALE: 1:1

F:\DWG\MISC\MKTG\ASP-214802-01-MKT.SLDDRW

samtec
 520 PARK EAST BLVD., NEW ALBANY, IN 47150
 PHONE: 812-944-6733 FAX: 812-948-5047
 e-Mail info@SAMTEC.com code 55322

DESCRIPTION:
 CUSTOM COM HPC MALE ASSEMBLY

DWG. NO.
ASP-214802-01

BY: R CURRY 10/17/2019 SHEET 8 OF 8