

24DCT Athlonix™

Ø 24 mm • Graphite-Copper commutation • 14.47 mNm

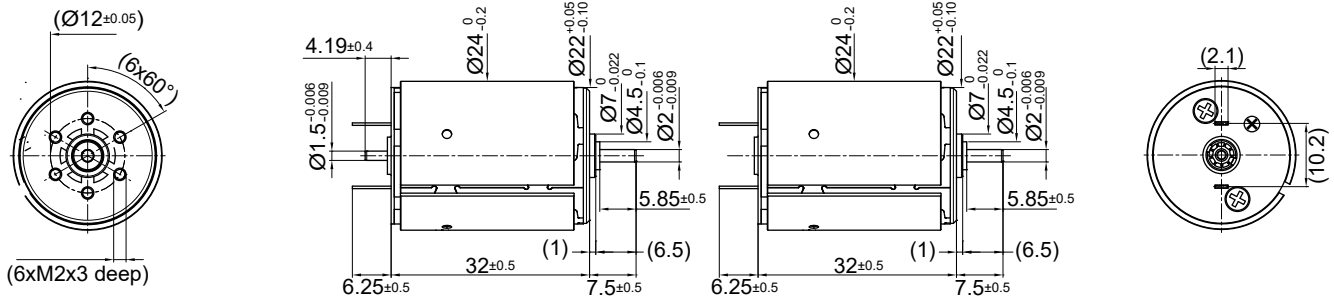

24DCT 32G2 2

24DCT 32G2 1

Dimensions in mm.

Electrical Data	Symbol	24DCT 32G2 *						Unit
		226P	221P	216P	215P	213P	212P	
1 Nominal Voltage	V	3	6	9	12	15	18	Volt
2 No-Load Speed	n_0	5651	7324	6414	7613	7342	7342	rpm
3 No-Load Current	I_0	90.3	58.0	33.9	30.1	23.2	19.3	mA
4 Terminal Resistance	R	0.6	0.9	2.2	2.7	4.3	6.1	Ω
5 Output Power	P_{2max}	3.6	7.1	6.9	8.8	8.7	8.8	W
6 Stall Torque	mNm	25.95 (3.68)	49.3 (6.99)	54.54 (7.73)	66 (9.35)	66.88 (9.48)	67.8 (9.61)	mNm (oz-in)
7 Efficiency	η_{max}	76	82	83	84	84	84	%
8 Max Continuous Speed	$n_{e max}$	10000	10000	10000	10000	10000	10000	rpm
9 Max Continuous Torque	$M_{e max}$	10.07 (1.43)	12.29 (1.75)	13.87 (1.97)	14.01 (1.99)	14.37 (2.04)	14.47 (2.05)	mNm (oz-in)
10 Max Continuous Current	$I_{e max}$	2.11	1.64	1.07	0.96	0.76	0.64	A
11 Back-EMF Constant	k_E	0.52	0.81	1.39	1.57	2.03	2.44	mV/rpm
12 Torque Constant	k_M	4.98	7.75	13.29	14.95	19.38	23.26	mNm/A
13 Motor Regulation	R/k^2	22.80	15.56	12.31	12.08	11.49	11.34	10 ³ /Nms
14 Friction Torque	T_F	0.45 (0.07)	0.45 (0.07)	0.45 (0.07)	0.45 (0.07)	0.45 (0.07)	0.45 (0.07)	mNm (oz-in)
15 Mechanical Time Constant	τ_m	10.78	7.47	5.88	5.70	5.45	5.33	ms
16 Rotor Inertia	J	4.73	4.80	4.78	4.72	4.74	4.70	g-cm ²

General Data

17 Thermal Resistance (rotor/body)	R_{th1}/R_{th2}	6/22						°C/W
18 Thermal Time Constant (rotor/stator)	t_{W1}/t_{W2}	9/550						S
19 Operating Temperature Range:	motor rotor	-30°C to 85°C (-22°F to 185°F) 100°C (212°F)						°C (°F) °C (°F)
20 Shaft Load Max.: (5 mm. from bearing)	-radial -axial	With sleeve bearings 3 (10.79) 100 (359.6)						N (oz) N (oz)
21 Shaft Play:	-radial -axial	0.03 (0.0012) 0.15 (0.0059)						mm (inch) mm (inch)
22 Weight	g	72 (2.54)						g (oz)
23 Commutation Segment	-	9						segment

*Also available with ball bearing

Execution Table

Gearbox	Single Shaft	MR2	E9
R22	4	5	6
K24	7	8	9
K27	1	2	3
R22HT	11	Upon Request	Upon Request

Note:

G1: standard commutation

G2: special commutation for double shaft version

- ▶ Motor shaft rotates CW when seen from motor front face when +ve and -ve supply is given to respective terminals.

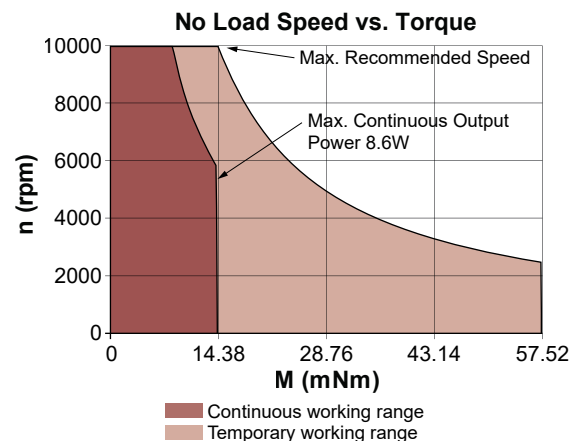

24DCT Athlonix™

Ø 24 mm • Graphite-Copper commutation • 14.47 mNm

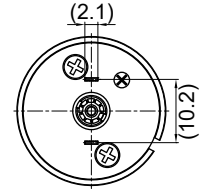
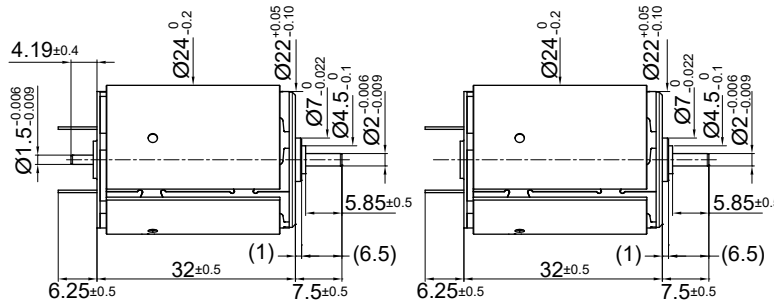
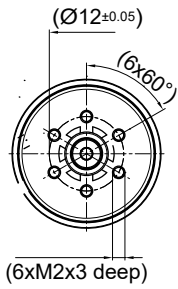

24DCT 32G2 2

24DCT 32G2 1

Dimensions in mm.

Electrical Data	Symbol	24DCT 32G2 *					Unit
		215E	214E	213E	212E	210E	
1 Nominal Voltage	V	21	24	30	36	48	Volt
2 No-Load Speed	n_0	6952	7048	7810	7810	7602	rpm
3 No-Load Current	I_0	15.7	13.9	12.4	10.3	7.5	mA
4 Terminal Resistance	R	10.1	13.0	16.4	23.6	46.3	Ω
5 Output Power	P_{2max}	7.7	7.8	9.0	9.0	8.4	W
6 Stall Torque	mNm	59.2 (8.39)	59.34 (8.41)	66.32 (9.4)	66.15 (9.37)	61.6 (8.73)	mNm (oz-in)
7 Efficiency	h_{max}	83	83	84	84	84	%
8 Max Continuous Speed	$n_{e max}$	10000	10000	10000	10000	10000	rpm
9 Max Continuous Torque	$M_{e max}$	13.88 (1.97)	13.8 (1.96)	13.86 (1.97)	13.84 (1.97)	13.53 (1.92)	mNm (oz-in)
10 Max Continuous Current	$I_{e max}$	0.50	0.44	0.39	0.32	0.23	A
11 Back-EMF Constant	k_E	3.00	3.38	3.82	4.58	6.27	mV/rpm
12 Torque Constant	k_M	28.63	32.27	36.44	43.72	59.86	mNm/A
13 Motor Regulation	R/k^2	12.30	12.44	12.33	12.36	12.92	10 ³ /Nms
14 Friction Torque	T_F	0.45 (0.07)	0.45 (0.07)	0.45 (0.07)	0.45 (0.07)	0.45 (0.07)	mNm (oz-in)
15 Mechanical Time Constant	τ_m	5.91	5.87	5.84	5.81	5.77	ms
16 Rotor Inertia	J	4.81	4.72	4.74	4.70	4.47	g-cm ²

General Data				
17 Thermal Resistance (rotor/body)	R_{th1}/R_{th2}	6/22		°C/W
18 Thermal Time Constant (rotor/stator)	t_{w1}/t_{w2}	9/550		S
19 Operating Temperature Range:	motor	-30°C to 85°C (-22°F to 185°F)		°C (°F)
	rotor	100°C (212°F)		°C (°F)
20 Shaft Load Max.: (5 mm. from bearing)	-radial	3 (10.79)		N (oz)
	-axial	100 (359.6)		N (oz)
21 Shaft Play:	-radial	0.03 (0.0012)		mm (inch)
	-axial	0.15 (0.0059)		mm (inch)
22 Weight	g	72 (2.54)		g (oz)
23 Commutation Segment	-	9		segment

*Also available with ball bearing

Execution Table

Gearbox	Single Shaft	MR2	E9
R22	4	5	6
K24	7	8	9
K27	1	2	3
R22HT	11	Upon Request	Upon Request

Note:
G1: standard commutation
G2: special commutation for double shaft version

► Motor shaft rotates CW when seen from motor front face when +ve and -ve supply is given to respective terminals.

