

THIS DRAWING IS UNPUBLISHED. RELEASED FOR PUBLICATION
 © COPYRIGHT BY TYCO ELECTRONICS CORPORATION. ALL RIGHTS RESERVED.

LOC	DIST	REVISIONS					
FT	0	P	LTR	DESCRIPTION	DATE	DWN	APVD
		AU		REVISED PER 0G3B-0288-04	4/5/04	SS	GS
		AU1		REVISED PER ECO-10-000443	13JAN10	KK	HMR

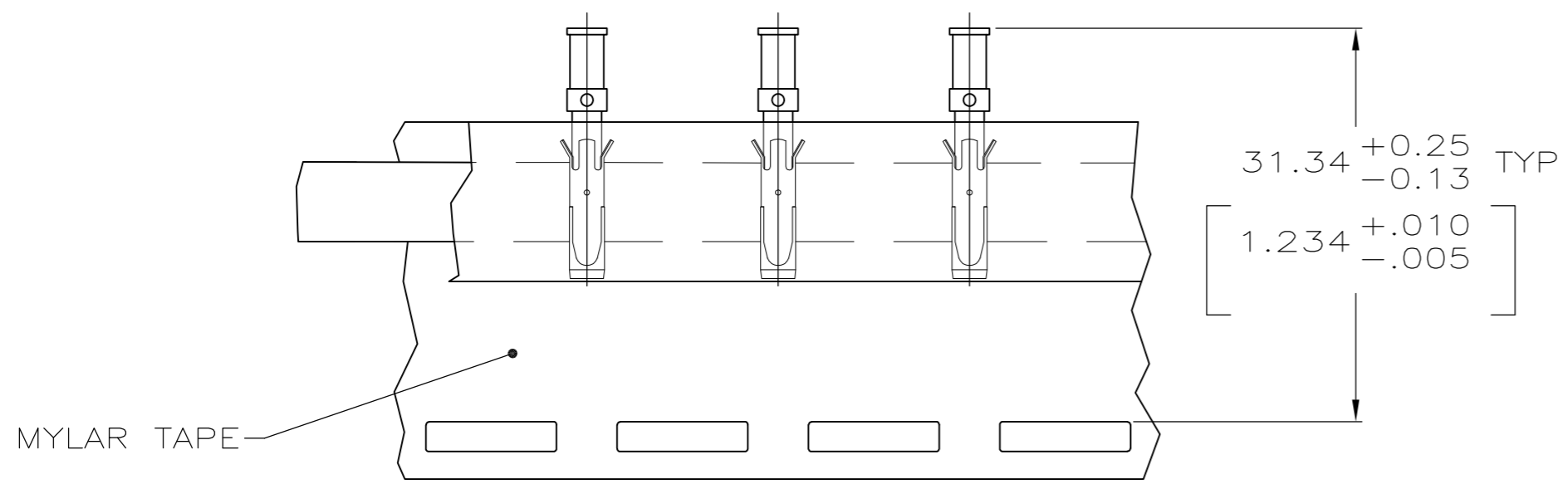
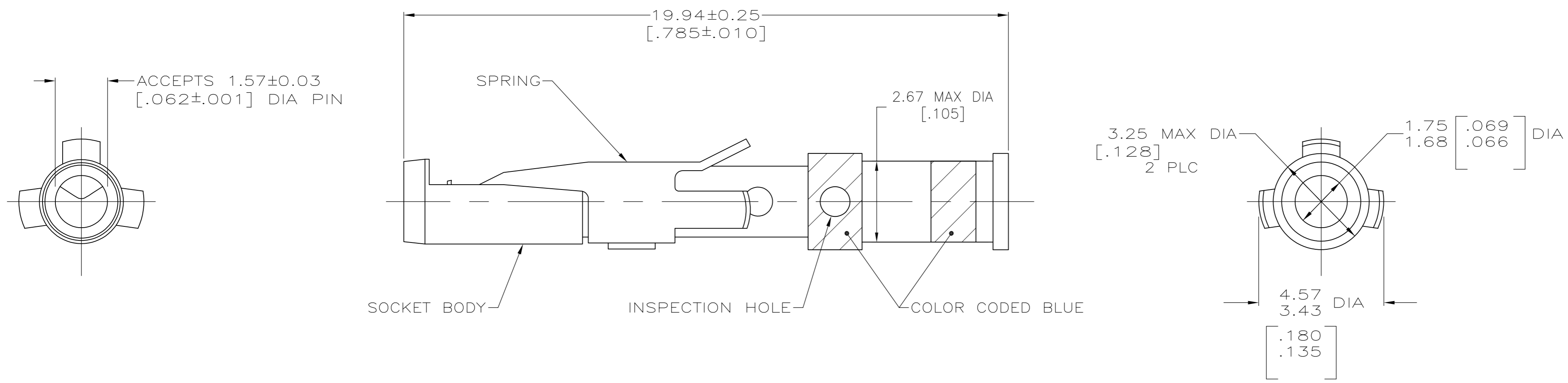

TAPE MTG DETAIL
SCALE 2:1

- ① 0.76µm [.000030] MIN GOLD OVER 1.27µm [.000050] MIN NICKEL.
- ② 1.27µm [.000050] MIN GOLD OVER 1.27µm [.000050] MIN NICKEL.
- ③ WHEN ORDERING CONTACT ASSEMBLY ON TAPE, ORDER BY THE TAPE NUMBER PLUS THE PACKAGING CODE AS FOLLOWS:
 1. FOR USE WITH AMP TAPETRONIC, PNEUMATIC TOOL—
 - A. 1000 PARTS TO A BOX ADD PACKAGING CODE: 1MBOX
 2. FOR USE WITH 4/8 INDENT STRIPPER CRIMPER—
 - A. 1000 PARTS TO A REEL ADD PACKAGING CODE: 1MREEL
 - B. 5000 PARTS TO A REEL ADD PACKAGING CODE: 5MREEL
- ④ NO COLOR CODING.
- ⑤ PRELIMINARY PART NUMBER.
- ⑥ OBSOLETE PARTS: OBSOLETE CIS STREAMLINING PER D.RENAUD/D.SINISI

PACKAGING TYPE	SOCKET BODY FINISH	PART NO.
STANDARD	①	1-200333-9
SMALL PACK	①	1-200333-8
STANDARD	②	1-200333-4
TAPE MTG (SEE DETAIL) ③	①	200333-8
STANDARD	①	200333-1

THIS DRAWING IS A CONTROLLED DOCUMENT.		DWN D.GELTZ 04/05/93	Tyco Electronics Corporation Harrisburg, Pa 17105-3608	
DIMENSIONS: INCHES		CHK R.STONE 4-26-93	NAME CONTACT ASSEMBLY, SOCKET, #16, TYPE II	
TOLERANCES UNLESS OTHERWISE SPECIFIED:		APVD -	PRODUCT SPEC -	
0 PLC ± -		APPLICATION SPEC -		
1 PLC ± -		WEIGHT -		
2 PLC ± -		SIZE A2		
3 PLC ± -		CAGE CODE 00779		
4 PLC ± -		DRAWING NO C=200333		
ANGLES ± -		RESTRICTED TO -		
FINISH		SCALE 10:1		
SOCKET BODY: COPPER ALLOY		SHEET 1 OF 1		
SPRING: STAINLESS STEEL		REV AU1		
CUSTOMER DRAWING				