

PART NAME: HANDLE

SCALE: 1:1

DATE: 12/7/16

DR. BY: JAM



P/N: 4571BB

THIS DRAWING IS THE PROPERTY OF DAVIES MOLDING COMPANY, IS SUBMITTED SOLELY AS A DESIGN OR ENGINEERING PROJECT
WE ACCEPT NO RESPONSIBILITY WHATSOEVER FOR THE PRACTICAL APPLICATION OF THE PIECES MADE TO THIS DESIGN.

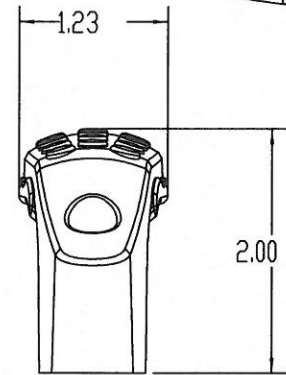
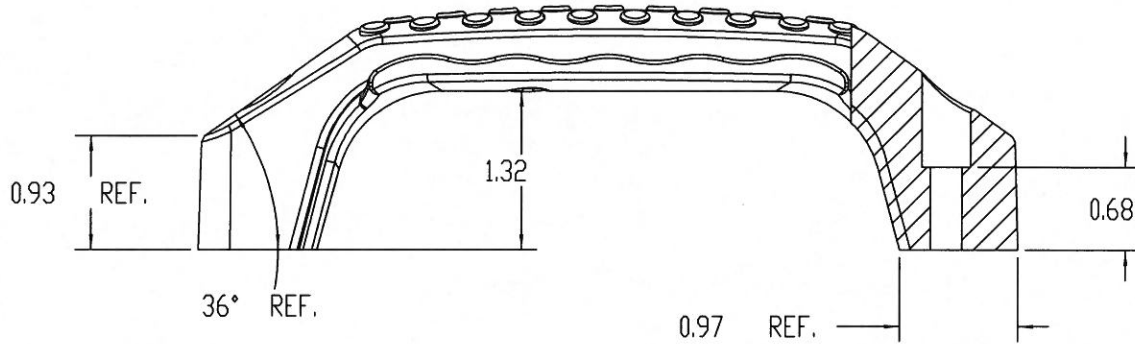
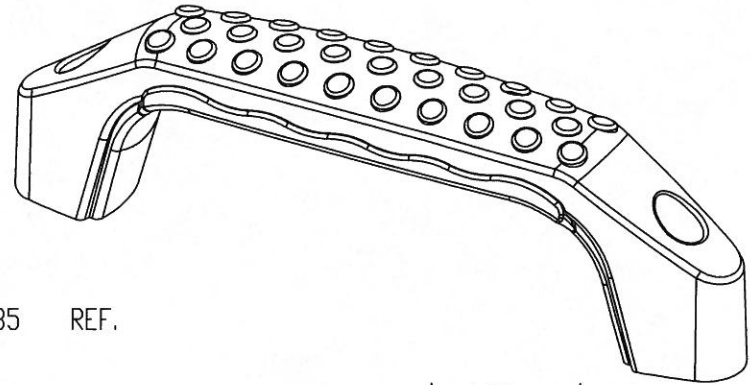
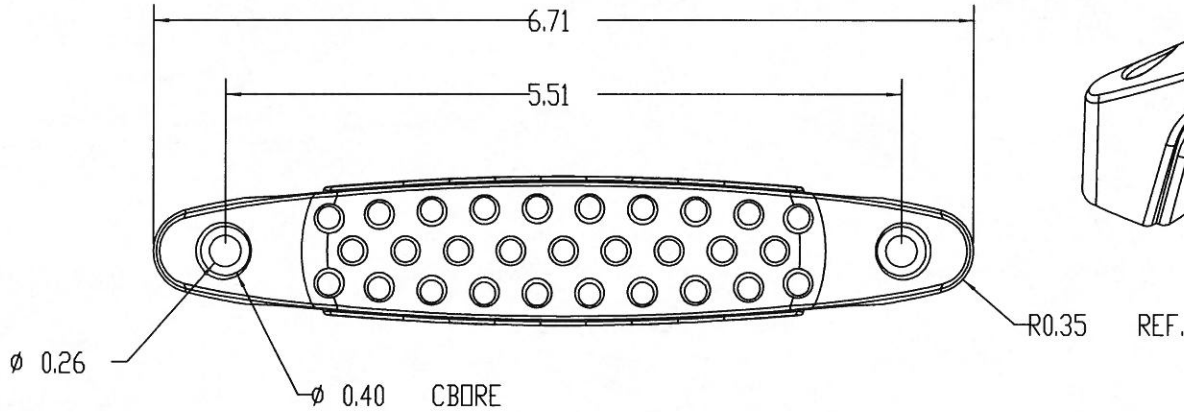

SUBSTRATE MATERIAL: 33% GLASS FILLED NYLON
COLOR: BLACK

OVERMOLD MATERIAL: TPE
COLOR: BLACK

| | | | | |
|---|---------------------------------|---------|--|--|
| TOLERANCES: UNLESS OTHERWISE SPECIFIED | DO NOT SCALE DRAWING | | | |
| DECIMALS: X.XXX ± .005 X.XX ± .015 | MM: X.XX ± 0.15MM XX ± 0.4MM | | | |
| FRACTIONS ± 1/64 | ANG. ± 1° | CHANGES | | |