



Automotive application guide

We make cars clean, safe and smart.



www.infineon.com/automotive



Contents

We make cars clean, safe and smart.	3	Powertrain applications	36
Safety applications	5	48 V micro-hybrid	37
Airbag system	6	Automatic transmission – hydraulic control	38
Reversible seatbelt pretensioner	7	Double-clutch transmission – hydraulic control	39
Brake Vehicle Stability Control (VSC)	8	Double-clutch transmission – electrical control	40
Electric brake booster	9	Gasoline multi-port injection – discrete solution	41
Electric parking brake	10	Gasoline multi-port injection – integrated solution	42
Electric Power Steering (EPS)	11	Gasoline direct injection	43
Active suspension control system	12	Diesel direct injection	44
Chassis domain control	13	LIN alternator regulator	45
Automotive 77 GHz radar system	14	Electric water pump	46
Automotive 24 GHz radar system	15	Fuel pump	47
Multi-purpose camera	16	Small engine starter kit	48
Sensor fusion	17	Small 1-cylinder combustion engine solution	49
Tire Pressure Monitoring System (TPMS)	18	(H)EV applications	50
In-cabin sensing applications	19	(H)EV – main inverter	52
Body and convenience applications	21	(H)EV – auxiliary inverter	53
Central body control module	22	(H)EV – auxiliary HV/LV DC-DC	54
High-feature body control module	23	(H)EV – AC-DC (battery charger)	55
Low-cost body control module	24	Car security	56
Gateway	25	Trusted driving with secured connectivity	56
HVAC control module	26	Telematics control unit	57
Decentralized front light module	27	Infineon PRO-SIL™	58
LED rear light module	28	Infineon's next level of Zero Defect program	59
Roof control module with interior and ambient light control	29		
Interior light control with capacitive touch sensor	30		
Power distribution for start-stop systems with a dual-battery approach	31		
Seat control module	32		
Decentralized mirror module	33		
Smart window lift/roof control module	34		
System-on-chip 3-phase motor control	35		

We make cars clean, safe and smart.

Infineon Technologies is a leading player and pioneer in automotive electronics. Our enduring success in this field is due to a clear strategic focus on automotive applications and standards, along with the understanding and insights that have emerged from over 40 years of dedicated experience and our ability to continually innovate this market with a broad portfolio of outstanding quality. Our sensors, microcontrollers and power semiconductors help automotive manufacturers achieve their increasingly challenging safety, affordability and efficiency targets. Above all, we are helping to create more sustainable mobility choices by lowering emissions and fuel consumption.

Paving the way for more sustainable mobility choices

In an increasingly mobile society, carbon dioxide emissions are rising and fossil fuel reserves are dwindling. The automotive industry faces the challenge of powering today's mobile lifestyle while simultaneously reducing its carbon footprint. Electronic components play a key role in increasing energy efficiency.

The demand for alternative, more energy-efficient forms of mobility is increasingly geared toward electromobility. Drivetrain electrification, whether in hybrid electric vehicles or – ultimately – fully electric vehicles, has the advantages of higher energy efficiency and zero tailpipe emissions. As the world leader in automotive and advanced power electronics, with over ten years of experience in electromobility, Infineon delivers a broad suite of best-in-class microcontrollers, power semiconductors and sensors that are helping to solve today's electromobility challenges.

As we transition toward greater electromobility, Infineon is also working with leading car manufacturers and system suppliers to improve the energy efficiency of combustion engines and the various subsystems in today's vehicles. We offer a range of dedicated products and solutions targeting hotspots such as demand-driven accessories, energy management and electric power distribution. These solutions embody Infineon's commitment to the exceptional quality and reliability that the world's leading vehicle manufacturers expect.

Reducing road fatalities

New Car Assessment Programs (NCAP) and governments all over the world have set ambitious road fatality reduction targets. The automotive industry actively contributes to road safety by developing and evolving technologies that reduce the likelihood or impact of accidents, for example by improving of reactive airbag and stability control systems. Similarly, new active safety features include adaptive cruise control and lane departure warning, where the vehicle acts proactively before a crash occurs.

Infineon is continuously optimizing the chipsets that enable the safety features designed to reduce the number of road accidents. With the most rigorous Euro NCAP in mind, we lead the field in many safety innovations for passive, active and preventive safety systems, such as RADAR technologies.

Complying with functional safety requirements

The increasing number of electronic systems leads to ever more considerations regarding the functional safety of vehicle systems. Infineon has adopted the ISO Standard 26262 for designing the appropriate products but also for setting up the appropriate processes for the development of such products.

Meeting increased data security demands

As system complexity increases in cars, so too does the volume of data to be processed and distributed. Auto-makers therefore need to ensure that information is processed securely and protected against external access and manipulation (e.g. car tuning or counterfeit spare parts). Furthermore, new payment methods, such as parking fees or road tolls, require a secure flow of transaction data. Infineon can draw on years of expertise in chip card and identification systems to propel automotive data security to the next level.



Safety applications

Both customer demands and government legislation continue to improve traffic safety. Electric and electronic safety systems play a key role in this trend. Electric power steering is a good example of how a safety application perfectly combines improved fuel efficiency with enhanced comfort.

Infineon is the broadest supplier with a portfolio extending from intelligent sensors and microcontrollers through automotive power standard products and Application-Specific Standard Products (ASSPs) to highly integrated customized Application-Specific ICs (ASICs). This comprehensive product portfolio – combined with our application expertise gained during four decades of activity in the automotive industry – positions us ideally to help customers overcome their key challenges. These include ongoing application optimization plus the implementation of new features to meet stringent safety requirements. The ISO 26262 safety standard is one example of the exacting standards that apply today.

To help customers to reach the desired Automotive Safety Integrity Level (ASIL) certification, Infineon has already introduced its own PRO-SIL™ concept. This trademark clearly identifies the products which contain “SIL-supporting” features. The Infineon PRO-SIL™ concept includes safety-focused organization and business processes for the generation of hardware and software safety features, including safety documentation.

The functional complexity and levels of integration of real-time safety-critical applications continue to increase exponentially. In addition, the product life cycle of these applications has to meet stringent safety standards. The ISO 26262 mandates more robust and comprehensive product development processes and functional safety concepts in automotive applications.

Airbag system

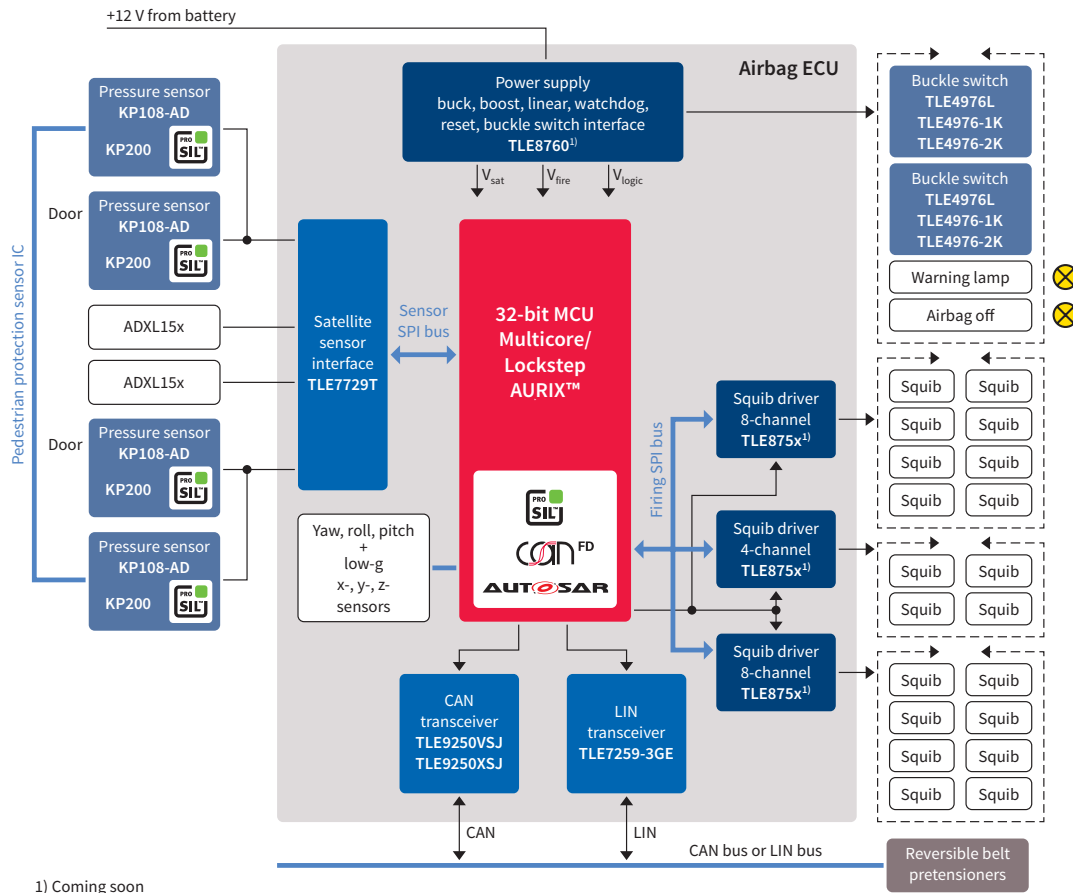

System benefits

- > Airbag systems are standard in most cars and are mandatory equipment in many countries, saving thousands of lives
- > Infineon’s broad product spectrum supports scalability and flexibility for building systems from 4 to over 20 firing loops
- > Full range of airbag ASSPs ranging from pressure sensors for side crash detection to driver and transceiver ICs
- > High-performance 32-bit AURIX™ MCU family with dedicated safety features enables the integration of multiple functions
- > The parts are optimized in terms of both system interoperability and the best price-performance ratio
- > These systems are mandatory in order to achieve the highest possible scores in the various “New Car Assessment Programs” (NCAP) throughout the world and are even required by law in some countries

Suggested products



Product name	Description
AURIX™	High-performance 32-bit multicore microcontroller family (PRO-SIL™)
TLE8754/8758	Airbag deployment ASSPs
TLE7729	Airbag satellite receiver
TLE9250VSJ/XSJ	CAN transceivers
TLE7259-3GE	LIN transceiver
KP108	Application-specific sensor for side airbag pressure sensing
KP200	Application-specific sensor for side airbag pressure sensing; fully PSIS-compliant (PRO-SIL™)
KP201	Application-specific sensor for pedestrian protection sensing (PRO-SIL™)
TLE4976	Hall switches for buckle switch application

Reversible seatbelt pretensioner

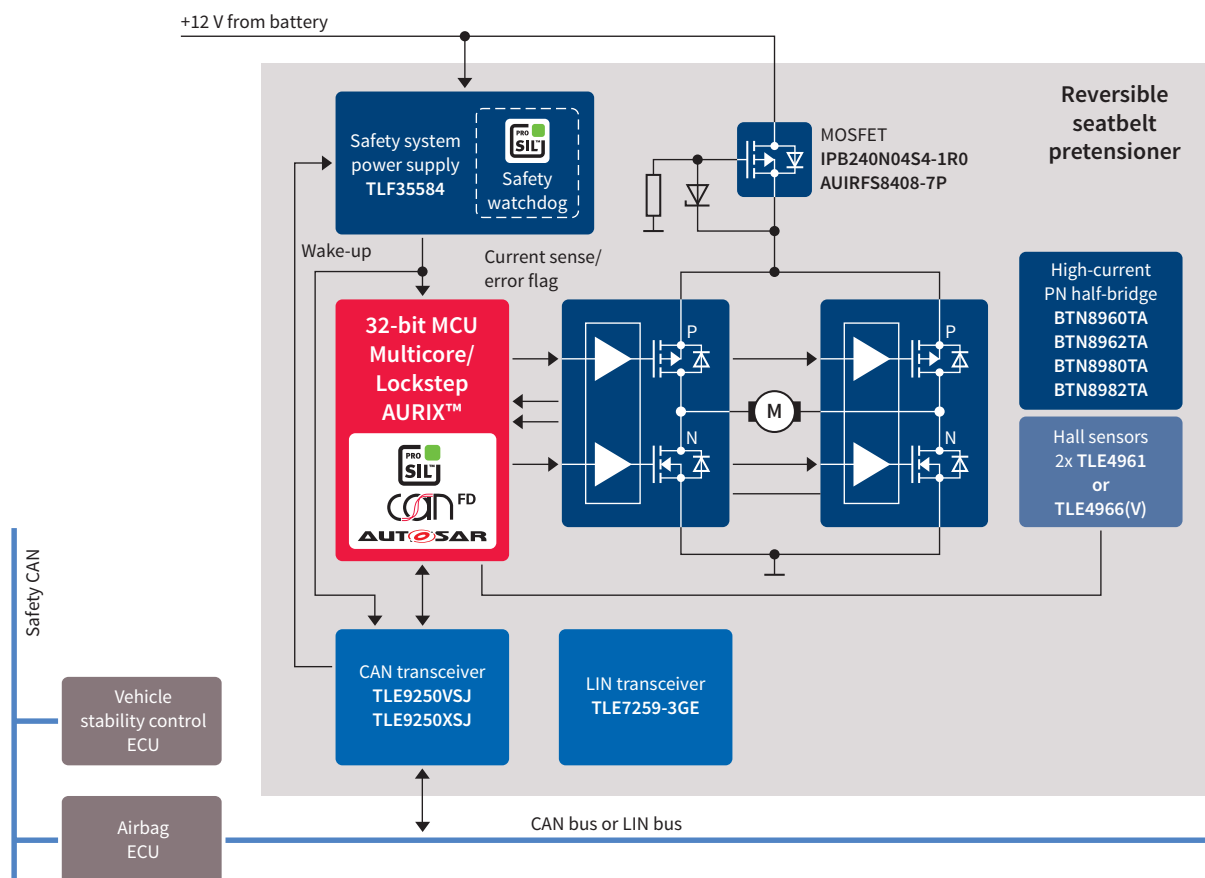

System benefits

- › Seatbelts are still the primary safety feature for protecting car passengers from severe harm
- › Correct belt tension before a crash reduces the severity of injuries while also increasing passenger comfort during normal use
- › Safety experts predict that reversible seatbelt pretensioners will become mainstream in the future
- › The illustration shows the partitioning of an Infineon system solution for this application which includes supply, microcontroller, sensor, power and communication ICs

Suggested products



Product name	Description
AURIX™	High-performance 32-bit multicore microcontroller family (PRO-SIL™)
TLF35584	System power supply with integrated watchdog (PRO-SIL™)
TLE9250VSJ/XSJ	CAN transceivers
TLE7259-3GE	LIN transceiver
TLE4961/TLE4966(V)	Hall switches for position/rotation sensing and rotor index counting
BTN89xx	High-current PN half-bridge ICs

Brake Vehicle Stability Control (VSC)

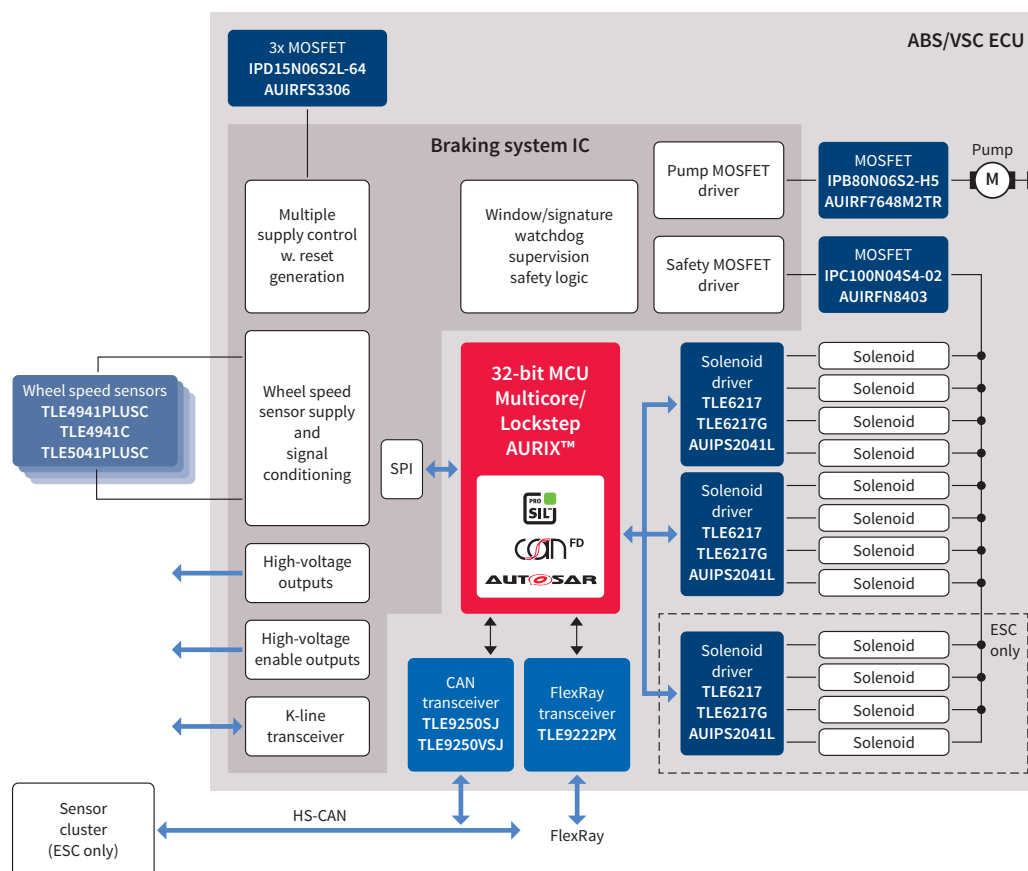

System benefits

- › Vehicle stability control systems can be found in all car classes on our roads, providing safety while reducing braking distances and keeping the car under control in critical situations
- › These systems are mandatory in order to achieve the highest possible scores in the various “New Car Assessment Programs” (NCAP) throughout the world and are even required by law in some countries
- › Infineon’s range of products for braking systems stretches from scalable microcontrollers, state-of-the-art wheel speed sensors, CAN and FlexRay transceivers to MOSFETs and valve drivers

Suggested products



Product name	Description
AURIX™	High-performance 32-bit multicore microcontroller family (PRO-SIL™)
TLE9250SJ/VSJ	CAN transceivers
TLE6217	Quad solenoid driver
IPD60Nxxx	OptiMOS™ N-Channel MOSFET family
TLE4941/42, TLE5041	Wheel speed sensors
TLE425x/TLS1xx	Linear voltage trackers for supplying sensors

Electric brake booster

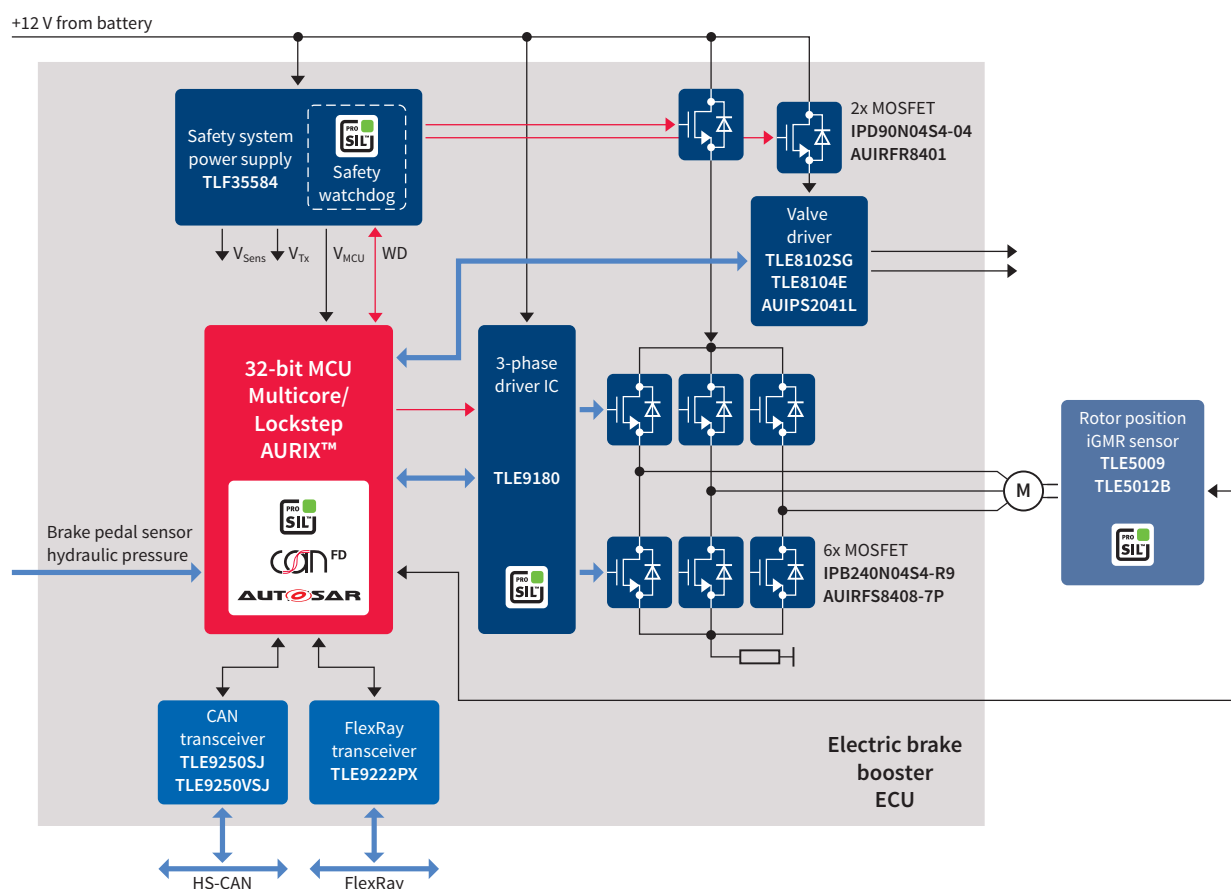

System benefits

- > Next-generation drivetrains, such as hybrid and electric vehicles and even contemporary highly efficient combustion engines, require a new braking assistance system
- > Current systems are mainly dependent on vacuums generated by the combustion engine or vacuum pumps, which use up electrical energy as well as package space under the hood and are not flexible enough for the driver assistance systems of tomorrow
- > The above illustration shows the new concept of a fully electric brake booster, incorporating vehicle stability control functionality with an efficient and flexible design

Suggested products



Product name	Description
AURIX™	High-performance 32-bit multicore microcontroller family (PRO-SIL™)
TLF35584	System power supply with integrated watchdog (PRO-SIL™)
TLE9180	3-phase bridge driver IC for automotive safety applications (PRO-SIL™)
TLE9250SJ/VSJ	CAN transceivers
TLE9222PX	FlexRay transceiver
IPB180N04S401 AUIRFR8401	OptiMOS™-T 40 V N-Channel MOSFET family, optimized for EPS applications
TLE499x	Linear Hall sensor family for torque and current sensing
TLE5009/12	iGMR sensors for rotor position sensing
TLE425x/TLS1xx	Linear voltage trackers for supplying sensors

Electric parking brake

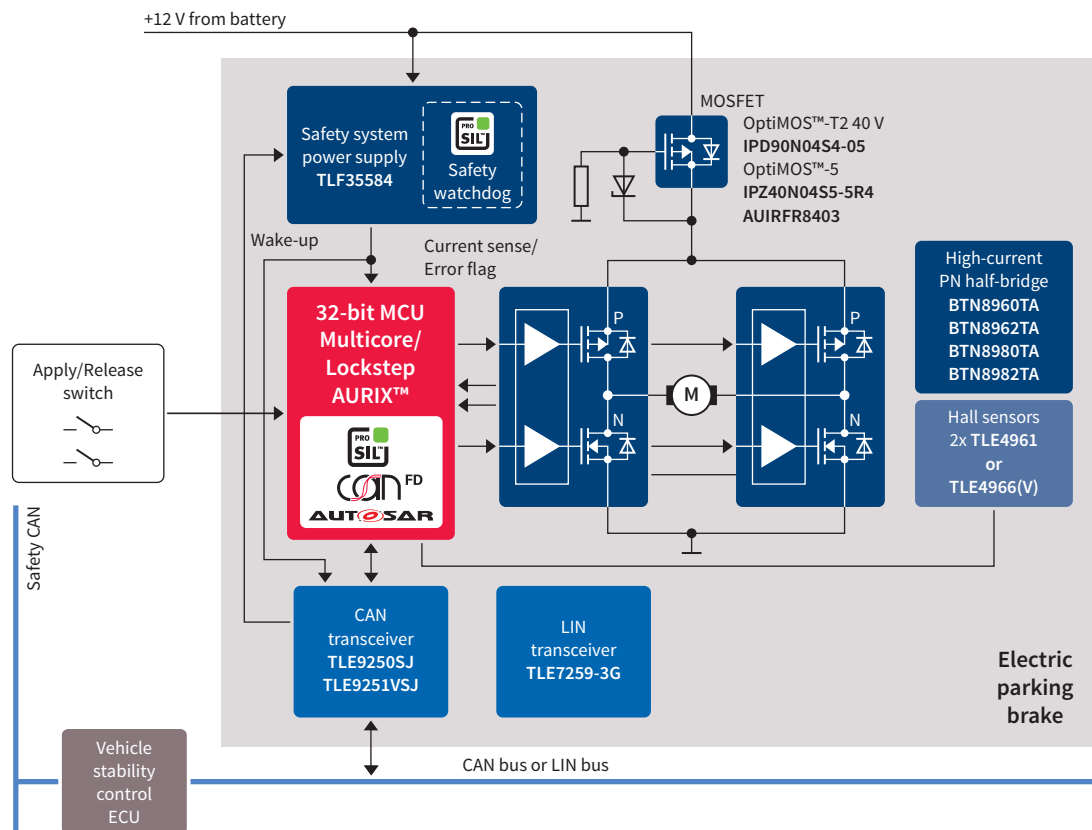

System benefits

- › The electric parking brake provides drivers with many more comfort and convenience features than the standard mechanical system
- › Hill hold, launch control and roll-away prevention are all possible
- › These convenience features are in many cases safety-relevant and should therefore be implemented using safety-compliant hardware (according ISO 26262)

Suggested products



Product name	Description
AURIX™	High-performance 32-bit multicore microcontroller family (PRO-SIL™)
TLF35584	System power supply with integrated watchdog (PRO-SIL™)
TLE9250SJ/TLE9251VSJ	CAN transceivers
TLE7259-3G	LIN transceiver
TLE4961/TLE4966(V)	Hall switches for position/rotation sensing and rotor index counting
BTN89xx	High-current PN half-bridge ICs
TLE425x/TLS1xx	Linear voltage trackers for supplying sensors

Electric Power Steering (EPS)

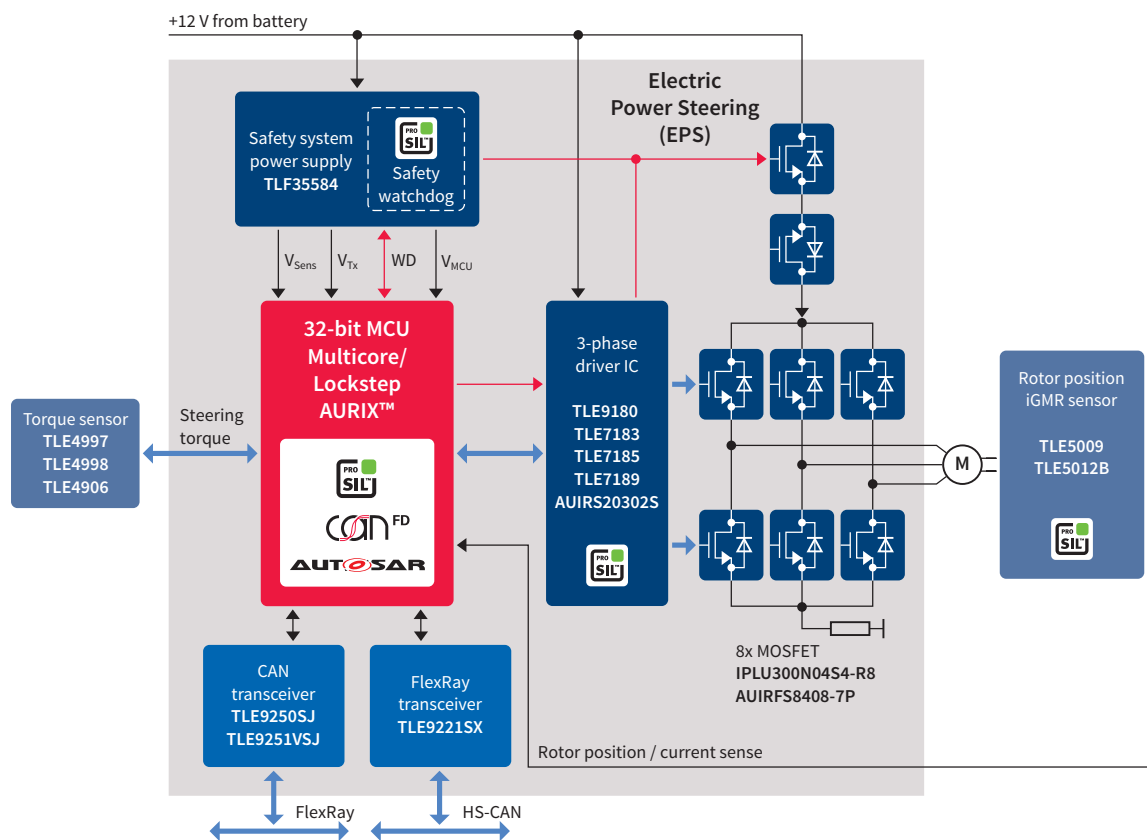

System benefits

- › Electric Power Steering (EPS) improves fuel efficiency by approximately 3 percent, while also having a positive impact on car handling, the overall driving experience and comfort
- › It combines a compact design with reduced mounting costs
- › EPS can be adapted via software to suit diverse car models as well as dedicated driving modes
- › EPS is the steering technology needed to enable advanced driver assistance systems such as side-wind compensation, lane assist/keeping and parking assistance systems
- › Infineon has over ten years of experience in this exciting application and provides the full range of ICs, from sensors to microcontrollers, and from bridge drivers to world-class MOSFETs

Suggested products

Product name	Description
AURIX™	High-performance 32-bit multicore microcontroller family (PRO-SIL™)
TLF35584	System power supply with integrated watchdog (PRO-SIL™)
TLE9180	3-phase bridge driver IC for automotive safety applications (PRO-SIL™)
TLE9250SJ/TLE9251VSJ	CAN transceivers
TLE9221SX	FlexRay transceiver
IPB180N04S4-01	OptiMOS™-T 40 V N-Channel MOSFET family in a TOLL package, optimized for EPS applications
TLE499x	Linear Hall sensor family for torque and current sensing
TLE5009/12	iGMR sensors for rotor position sensing
TLE425x/TLS1xx	Linear voltage trackers for supplying sensors



Active suspension control system

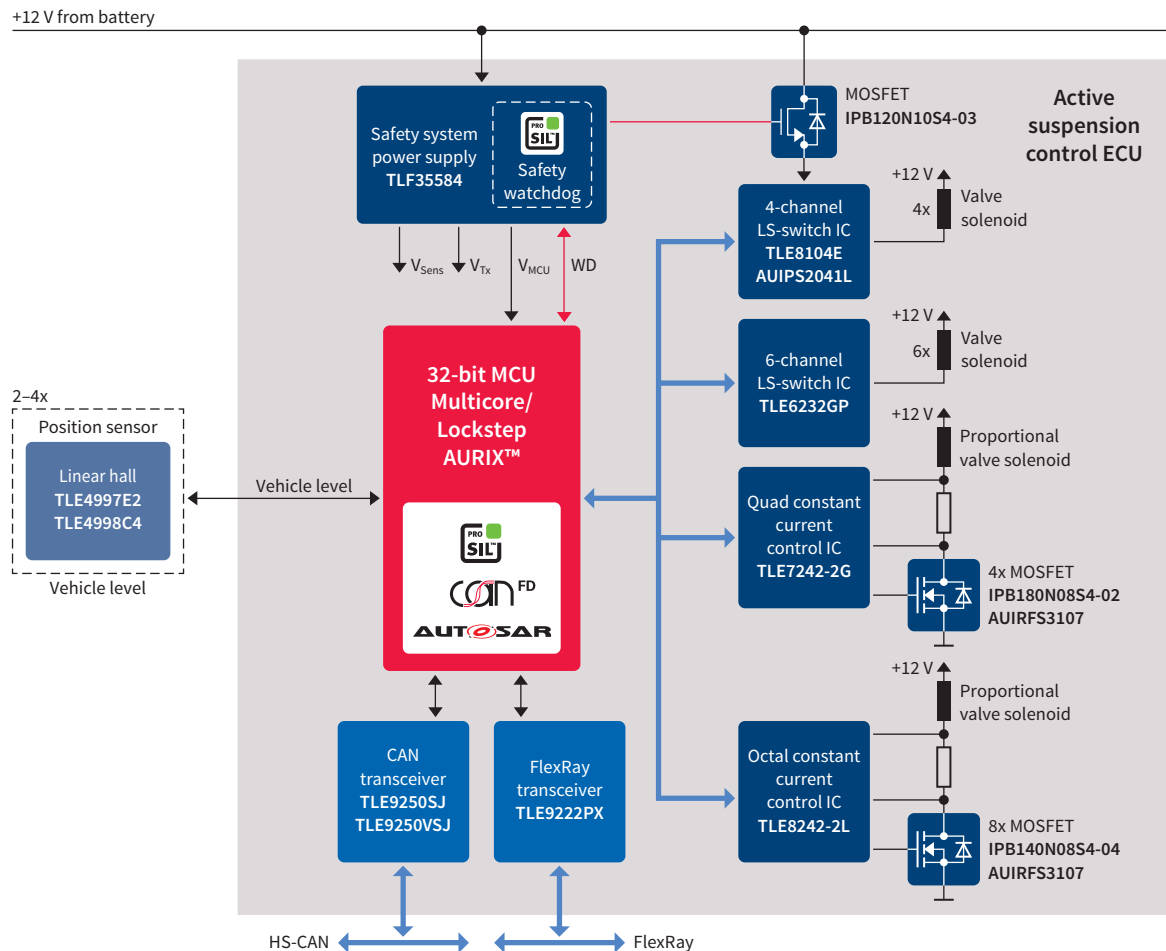

System benefits

- Advanced suspension systems originally used in high-end sports and luxury cars are now prevalent in the mid-market car segment
- By adapting both the vehicle's leveling and damping characteristics, these systems significantly improve car comfort, handling performance and driving safety
- Infineon's broad product spectrum – including high-end 32-bit microcontrollers as well as multi-channel drivers for bistable and analog valves – covers the full range of suspension systems, ranging from car/load leveling, semi-active to active suspension and air-suspension systems

Suggested products



Product name	Description
AURIX™	High-performance 32-bit multicore microcontroller family (PRO-SIL™)
TLF35584	System power supply with integrated watchdog (PRO-SIL™)
TLE6232GP	6-channel low-side switch IC
TLE8104E	4-channel low-side switch IC
TLE7242G	Quad constant current pre-driver IC
TLE9250SJ/VSJ	CAN transceivers
TLE9222PX	FlexRay transceiver
TLE8242-2L	Octal constant current pre-driver IC
TLE4997/98	Linear Hall sensors for vehicle level sensing
TLS202B1MEV50	Post regulator to supply CAN transceiver
TLE425x/TLS1xx	Linear-voltage trackers for supplying sensors

Chassis domain control

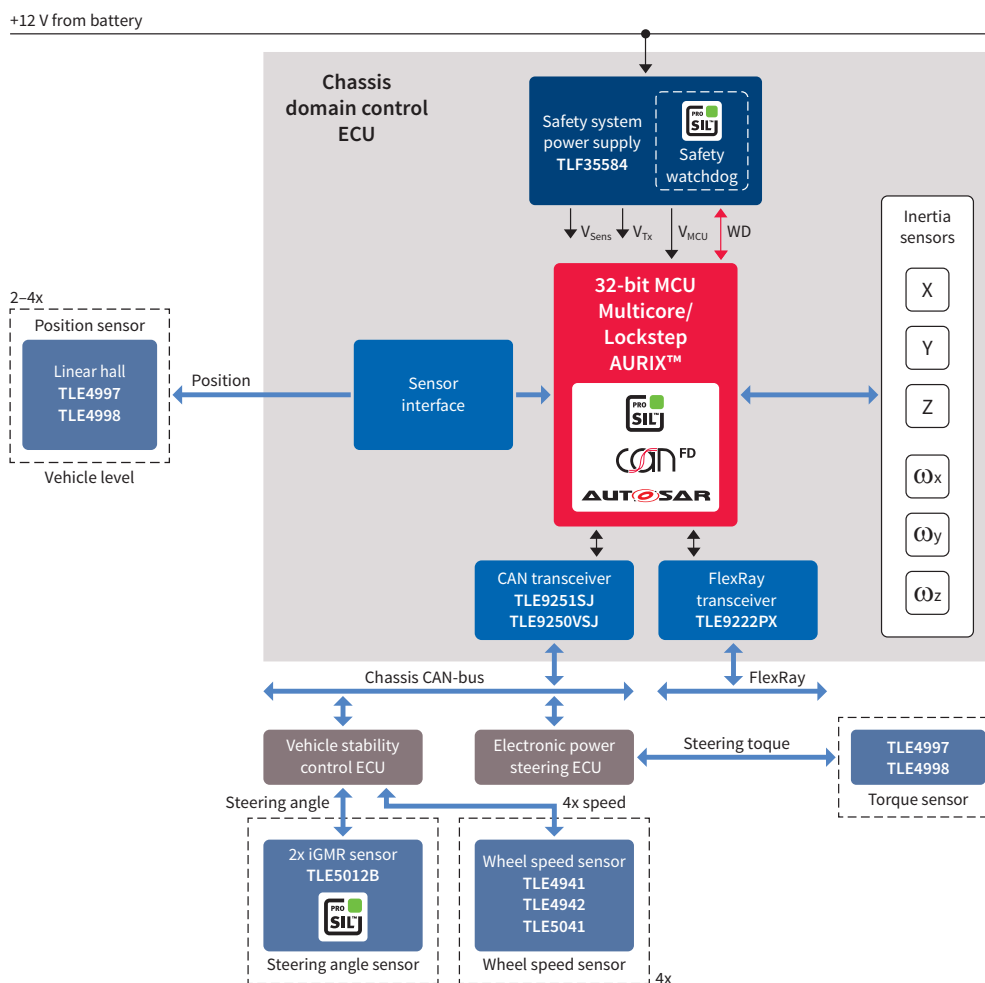

System benefits

- > The chassis domain control approach provides a high-performance, scalable and safe computing platform which already includes the sensor cluster with all its multi-axle inertia sensors
- > Domain controllers allow a cost-efficient x-check and fusion of the inertia sensor signals, as well as highly efficient and safe computing of the vehicle dynamic model
- > Consequently, the chassis domain control unit represents a promising approach to perfectly coordinating functions such as VSC, semi-active suspension and drivetrain, especially when a four-wheel drive with torque vectoring is required

Suggested products



Product name	Description
AURIX™	High-performance 32-bit multicore microcontroller family (PRO-SIL™)
TLF35584	System power supply with integrated watchdog (PRO-SIL™)
TLE9251SJ/VSJ	CAN transceivers
TLE9222PX	FlexRay transceiver
TLE5012	iGMR sensor with integrated 8-bit microcontroller
TLE4997/98	Linear Hall sensors
TLS202B1MEV50	DC-DC converter
TLE425x/TLS1xx	Linear-voltage trackers for supplying sensors

Automotive 77 GHz radar system

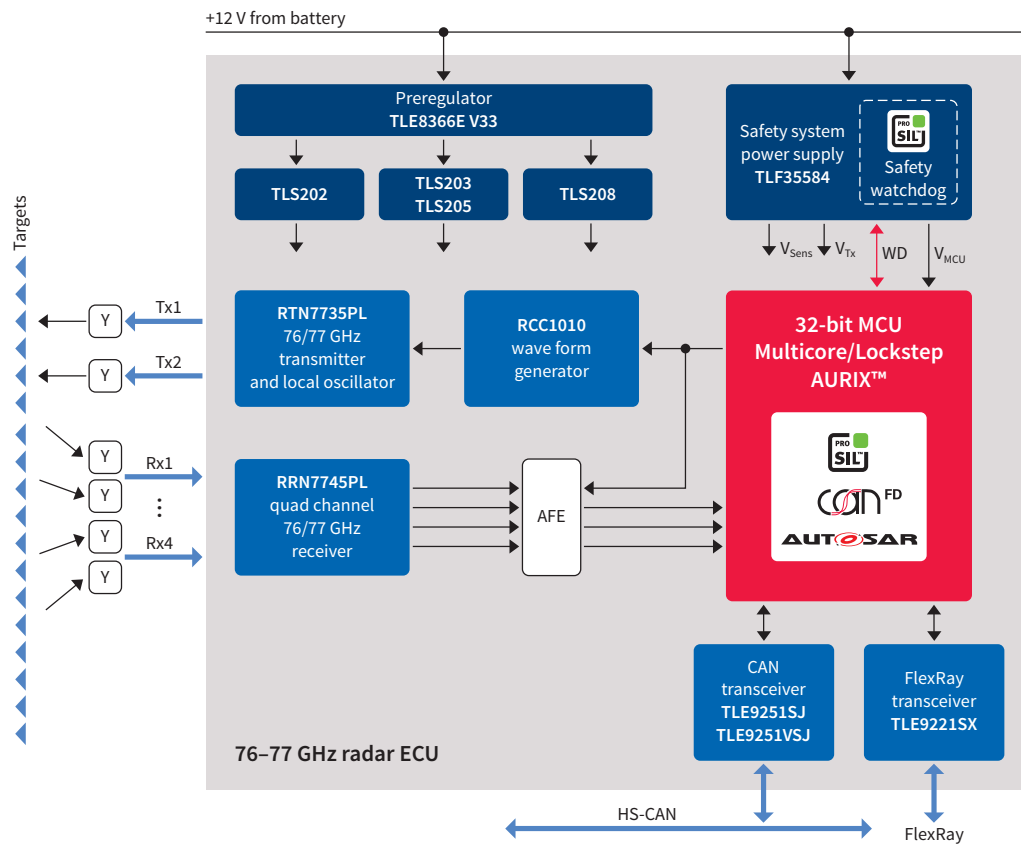

System benefits

- › Automotive radar sensors are a key technology for enabling future driver assistance functions and securing high ratings in New Car Assessment Programs (NCAP) throughout the world
- › The Radar System IC (RASIC™) series consists of a group of highly integrated functions for the 76–77 GHz range for automotive radar
- › The ICs offer a high level of integration and need only a few – if any – external components
- › Infineon’s SiGe process benefits from its origins in the volume bipolar segment. Its unique features include its high-frequency capability and robustness, making it suitable for automotive environments over the full temperature range up to full automotive qualification according to AEC-Q100
- › Infineon’s AURIX™ 32-bit multicore ADAS derivative offers a dedicated feature set for radar applications which, in many cases, renders additional DSP, external SRAM and external ADC ICs obsolete. This results in cost-efficient short-range radar implementation.

Suggested products

Product name	Description
AURIX™	Powerful 32-bit multicore microcontroller family with dedicated ADAS features (PRO-SIL™)
TLF35584	System power supply with integrated watchdog (PRO-SIL™)
TLE9251SJ/TLE9251VSJ	CAN transceivers
TLE9221SX	FlexRay transceiver
RTN7730	76/77 GHz radar 2-channel transmitter IC
RRN7740	76/77 GHz radar 4-channel receiver IC
RCC1010	Wave form generator IC
TLS20x	Low noise linear post regulators



Automotive 24 GHz radar system

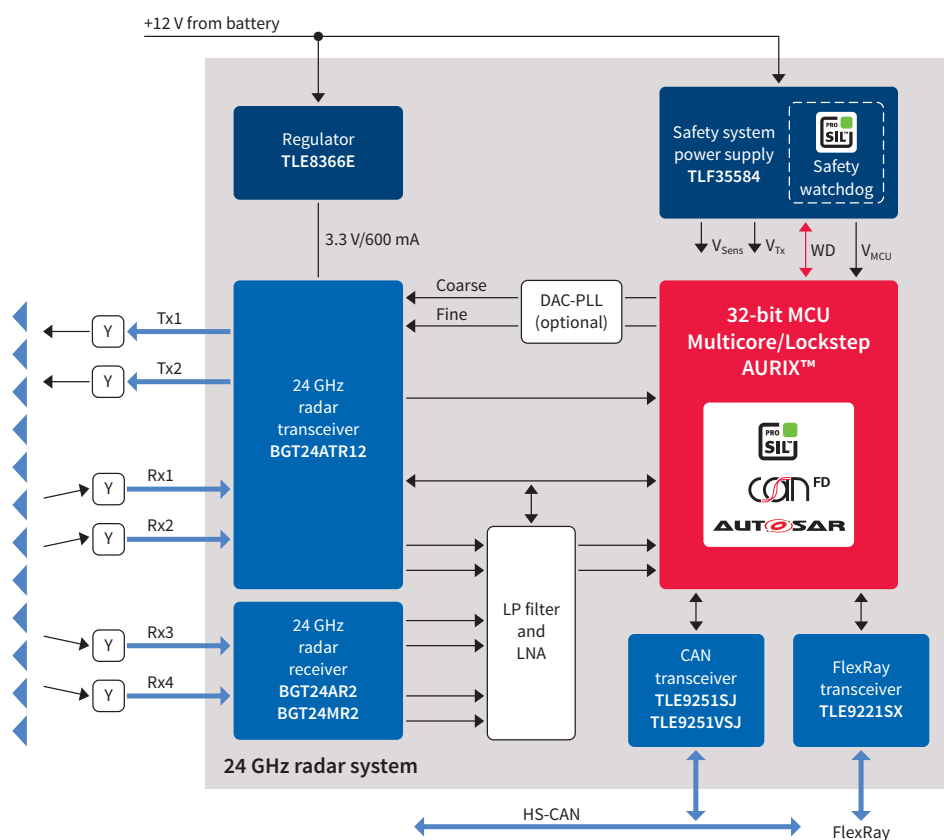

System benefits

- > Infineon's 24 GHz radar technology offers a cost-efficient solution for driver assistance systems such as blind spot detection
- > The Infineon 24 GHz transceiver is a highly integrated, SPI-controlled solution consisting of a VCO, medium-power amplifier, power amplifier, frequency dividers, several sensors and two complete IQ receivers
- > The signal generation unit is a standalone transmitter MMIC with the fully integrated IQ twin-receiver MMIC, in which two complex homodyne down-conversion mixers are combined; a lot of different system architectures can be served by combining the individual components
- > With its SiGe-based technology, Infineon is the first big market player to offer a competitive solution with a long-term roadmap approach for any kind of short-range radar ADAS applications
- > Infineon's AURIX™ 32-bit multicore ADAS derivative offers a dedicated feature set for radar applications which, in many cases, renders additional DSP, external SRAM and external ADC ICs obsolete. This results in cost-efficient short-range radar implementation

Suggested products

Product name	Description
AURIX™	Powerful 32-bit multicore microcontroller family with dedicated ADAS features (PRO-SIL™)
TLF35584	System power supply with integrated watchdog (PRO-SIL™)
TLE9251SJ/TLE9251VSJ	CAN transceivers
TLE9221SX	FlexRay transceiver
BTG24AR2	24 GHz radar 2-channel receiver IC
BGT24ATR12	24 GHz radar 1-channel transmitter, 2-channel receiver IC
TLS20x	Low noise linear post regulators



Multi-purpose camera

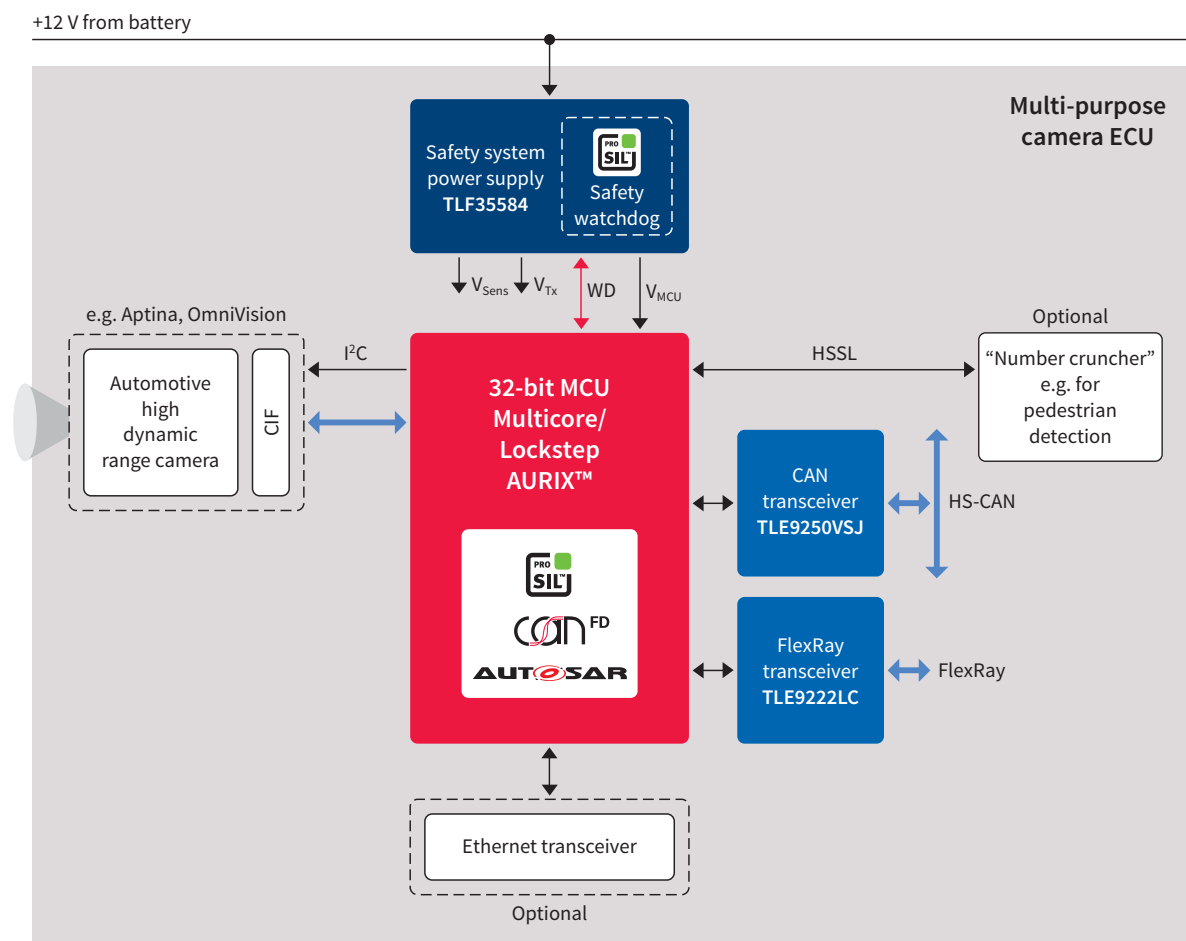

System benefits

- › The market for automotive cameras is quickly growing, enabling advanced driver assistance functions such as lane departure warning, forward collision warning, along with traffic sign and pedestrian recognition
- › Infineon offers a highly integrated solution to enable compact and efficient camera systems for the next generation of assistance functions
- › This includes ISO 26262 support, innovative supply concepts and best-in-class power consumption
- › AURIX™ multicore architecture includes encapsulation features to support freedom from interference between multiple applications

Suggested products

Product name	Description
AURIX™	High-performance 32-bit multicore microcontroller family (PRO-SIL™)
TLF35584	System power supply with integrated watchdog (PRO-SIL™)
TLE9250VSJ	CAN transceivers
TLE9222LC	FlexRay transceiver
TLS20x	Low noise linear post regulators



Sensor fusion

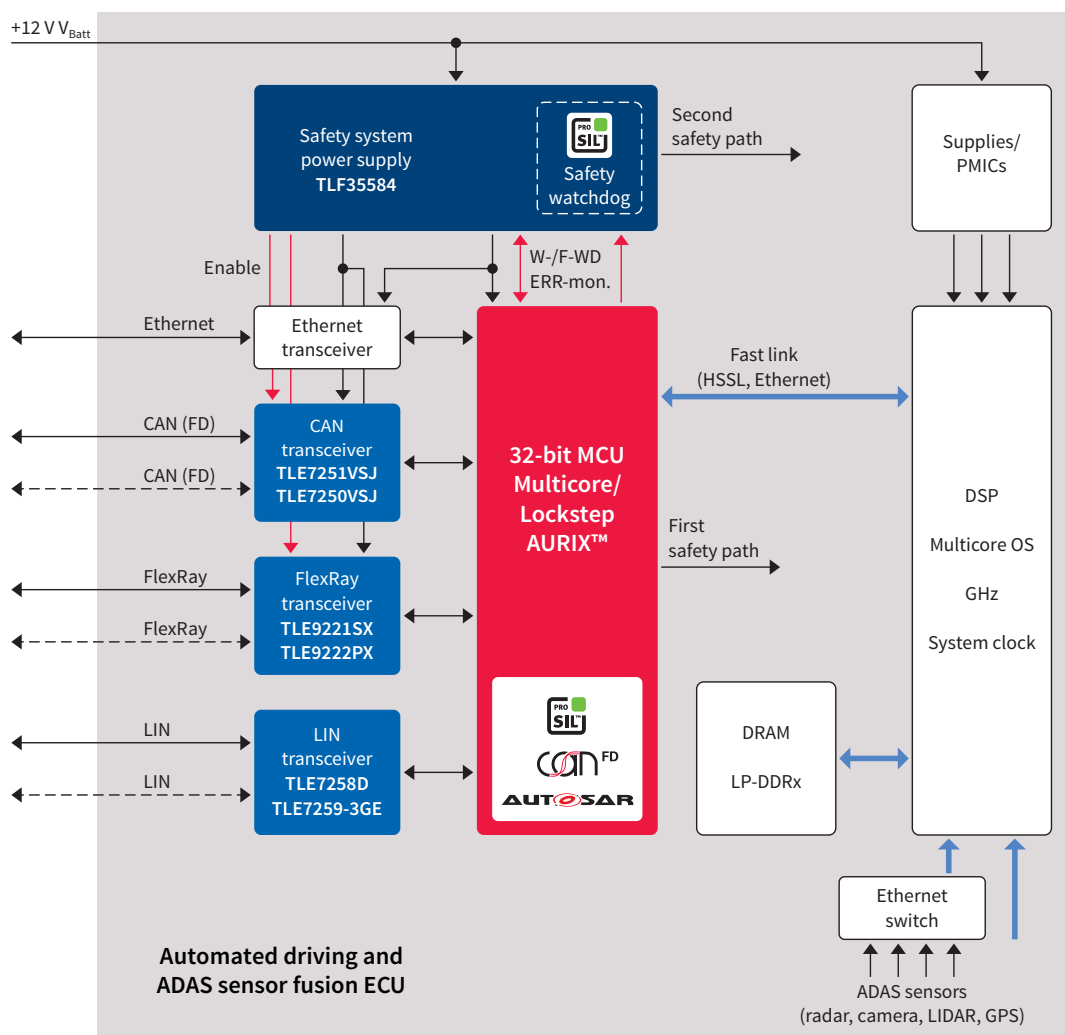

System benefits

- > Enables the sensor data fusion of several environmental sensors such as radar, camera, ultrasonic and lidar
- > Enhanced ADAS functions, such as cross traffic assist and autonomous obstacle avoidance, require the data from more than one sensor and the corresponding sensor fusion
- > Since the system can make critical, autonomous decisions, safety and security implementation is a must and is supported by Infineon’s high-performance AURIX™ micro-controller
- > AURIX™ combined with the TLF35584 safety power supply and a dedicated processor enables new and enhanced ADAS features

Suggested products

Product name	Description
AURIX™	High-performance 32-bit multicore microcontroller family (PRO-SIL™)
TLF35584	System power supply with integrated watchdog (PRO-SIL™)
TLE7251	CAN transceiver
TLE9221	FlexRay transceiver
TLE7259	Lin transceiver



Tire Pressure Monitoring System (TPMS)

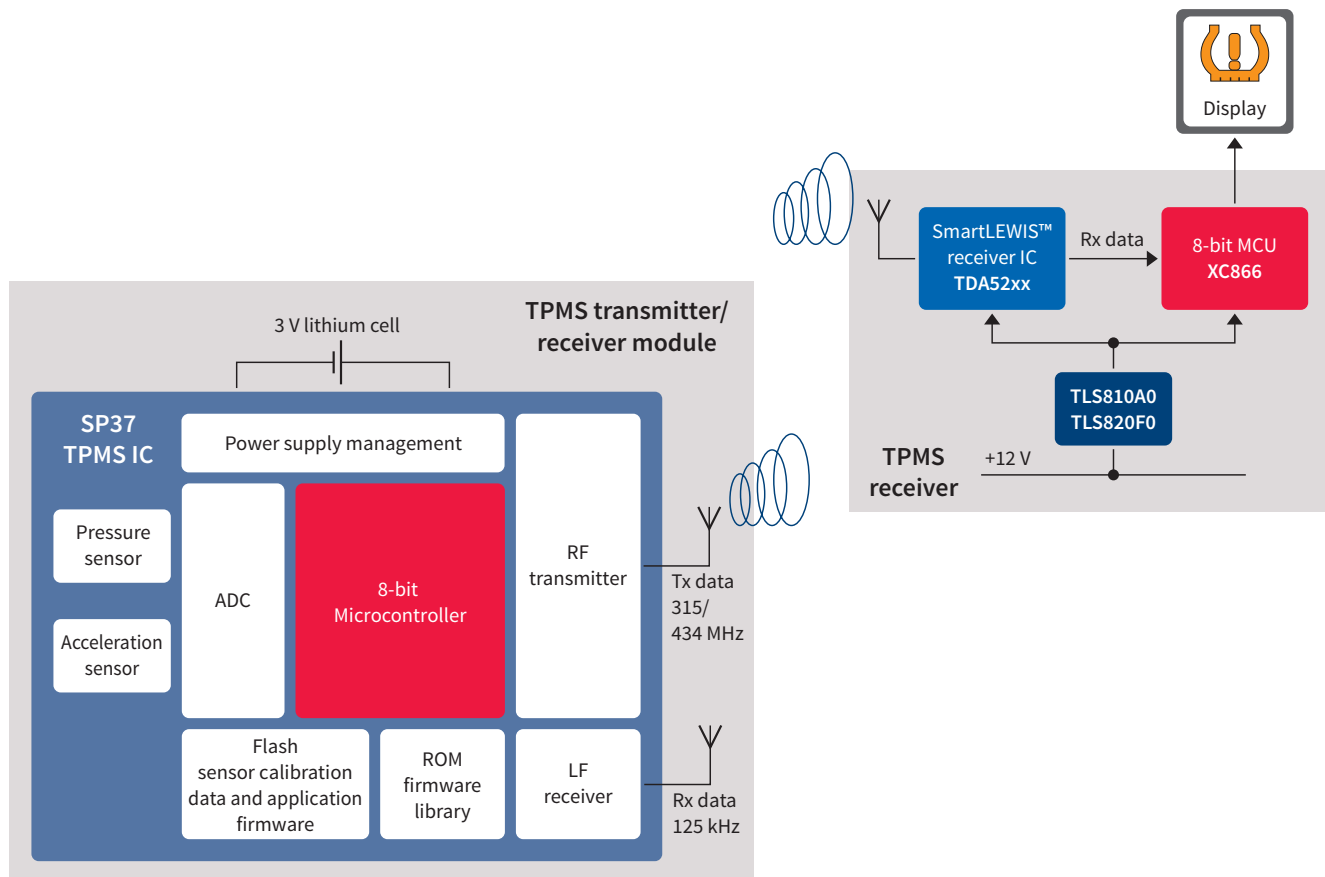

System benefits

- › TPMS ensures correct tire pressure which is essential for car safety, handling, comfortable driving and tire lifetime
- › Furthermore, accurate tire pressure prevents increased fuel consumption/CO₂ emissions
- › TPMS is already mandatory in the USA, EU and South Korea
- › Infineon’s TPMS IC SP37 provides
 - various surveillance functions ensuring reliable measurements
 - a per-calibrated pressure sensor system for instant use
 - a fully packaged sensor system proven to withstand harsh automotive environments
 - a microcontroller-based architecture that enables flexible system design
 - a high level of integration for reducing the overall system component count
 - an increased tire lifetime by up to 30 percent

Suggested products

Product name	Description
XC8xx	8-bit microcontroller family with dual-cycle 8051 core
Supply ICs	Linear voltage regulators, DC-DC converters
TDA52xx	SmartLEWIS™ RX autonomous receiver
TDK51xx	Wireless control transmitter
SP37	Highly integrated TPMS with integrated microcontroller and RF transmitter for pressure ranges 450 kPa, 900 kPa, 1300 kPa (trucks)

In-cabin sensing applications

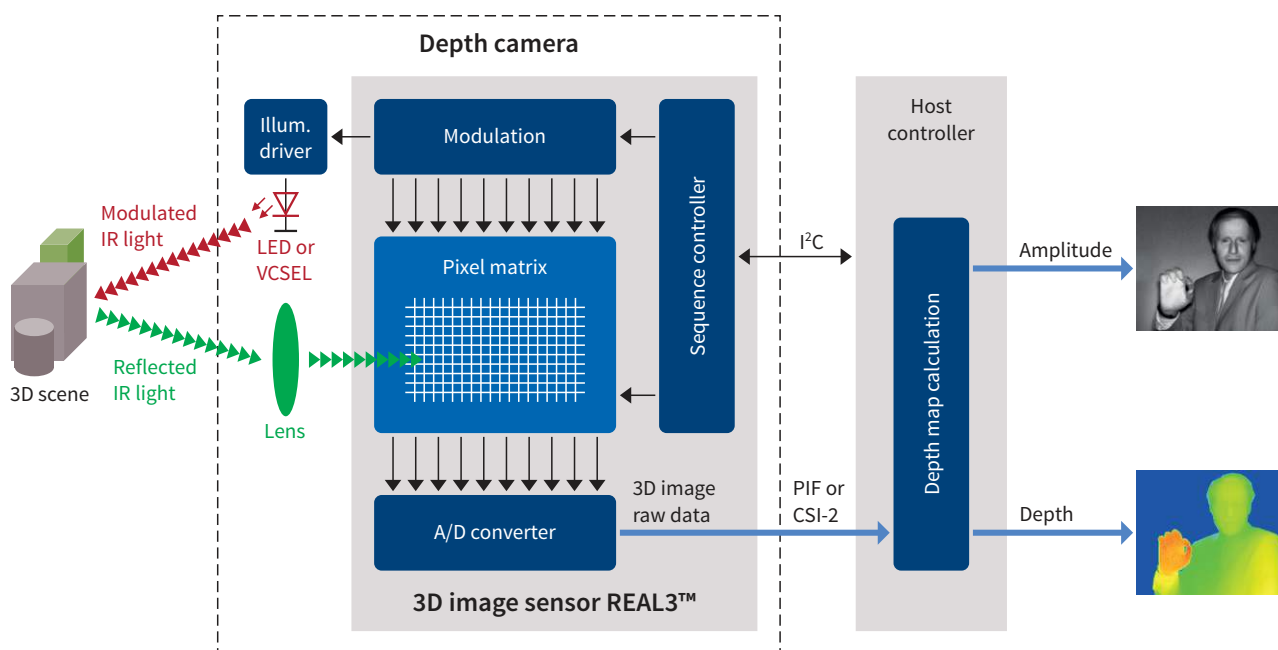

System benefits

- > Highly robust 3D data based on the Time-of-Flight principle with an outstanding depth performance and lowest power consumption
- > Reliable in all ambient light conditions – in sunlight, darkness and changing light levels
- > Smallest footprint thanks to single-chip design and monocular 3D camera architecture
 - no baseline between active parts
 - no risk of misalignment, for example through temperature fluctuations or vibrations
 - minimum calibration work
- > Reduced computing time, regardless of the color, pattern and structure of objects

Suggested products

Product name	Description
IRS1125A ¹⁾	3D image sensor REAL3™ with 100 k pixel resolution (352 x 288 pixel), automotive-qualified BGA package

1) IRS1125A is in development and for selective customer projects only; SOP planned for Q4/2018



Body and convenience applications

Infineon offers a wide variety of products dedicated to body and interior electronics. These include protected power switches for bulb and motor control, dedicated system basis chips and easy-to-use Hall sensor solutions. The new TriCore™-based AURIX™ family provides sufficient performance, as well as dedicated safety and security features, to meet the needs of upcoming domain electronics modules. As one example, a **high-feature body control module with integrated gateway** functionality is shown on page 23.

The following pages present well-known electronic modules for car body interior and comfort systems, such as the **body control modules** including a dedicated low-cost version, the Seat Electronics Module and the **HVAC control module**. Further modules reveal the growing trend toward decentralized modules at the point of load, such as a **front light module** or a **smart window lift module**.

Some new electronic module designs reflect the latest functional and architectural advances. One prominent example is a **power distribution system** for high-current applications supporting the move toward more advanced and efficient wiring harness systems in start/stop-capable vehicles. Another example is an **interior light module with touch-sensitive control** based on a similar human-machine interface to that featured in the latest consumer electronics devices. Finally, the growing family of system-on-chip devices supports space- and cost-optimized single-chip solutions for various motor control applications, such as window lift, fuel pump and HVAC blower.

Central body control module

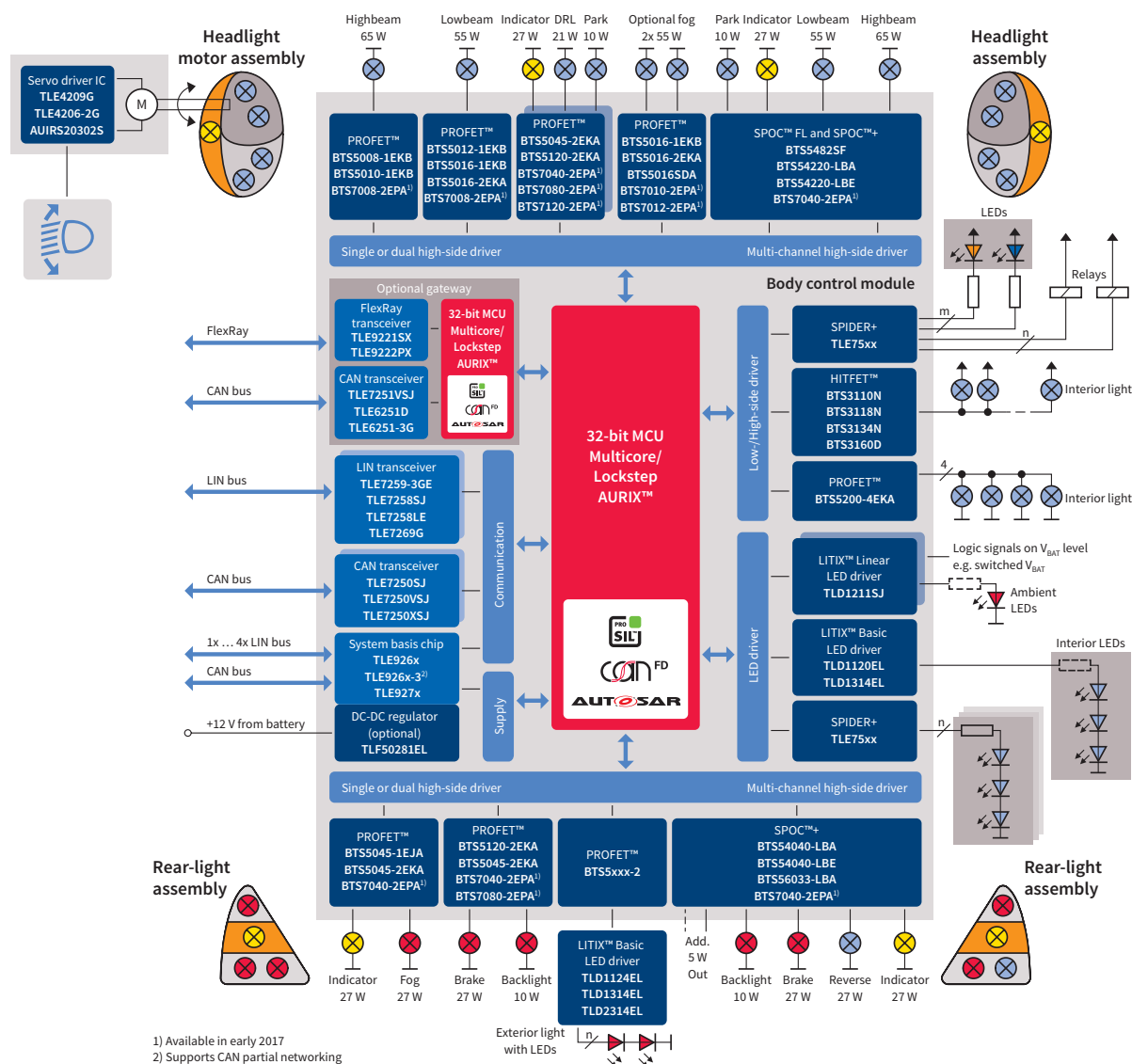

System benefits

- Reduced board space due to integrated functionality
- Protected load control with sophisticated diagnostic features
- Supports the “Limp Home” functional safety concept
- High scalability and benchmark short-circuit robustness of power semiconductors (PROFET™)
- Supports a smooth transition to LEDs for interior and exterior lighting

Suggested products

Product family	Description
AURIX™	Scalable 32-bit TriCore™ microcontroller family from single to multicore (PRO-SIL™)
Supply ICs	Linear voltage regulators, DC-DC converters
SPIDER, HITFET™	Single- and multi-channel protected high- and low-side switches
LITIX™ Basic LED driver	Linear current sources for LED applications
SBCs, network transceiver	System basis chips, CAN, LIN and FlexRay transceiver
PROFET™, SPOC™+	Single- and multi-channel protected high-side switches



High-feature body control module

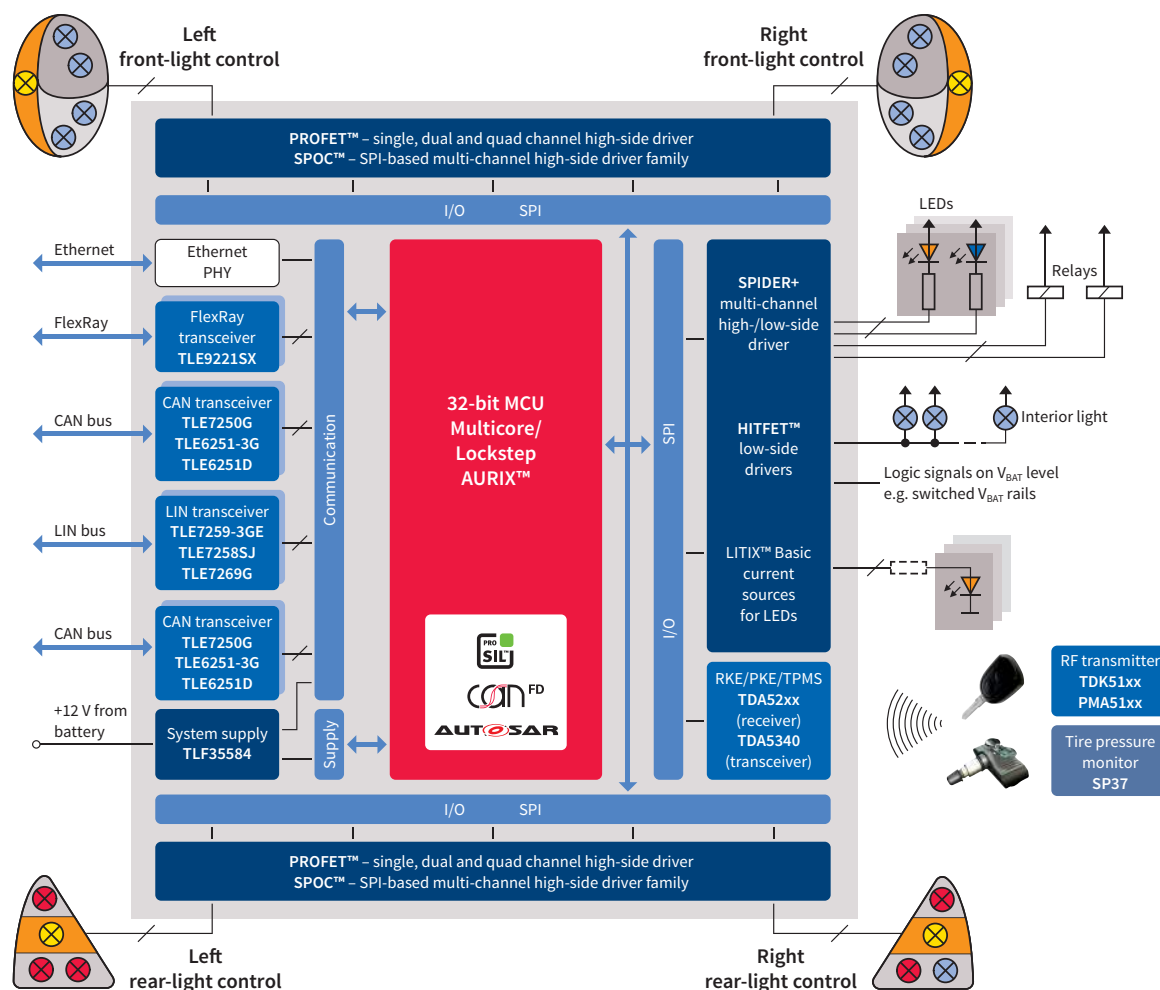

System benefits

- › AURIX™ multicore concept enables the integration of two applications into one device.
- › AURIX™ supports safety requirements up to ASIL-D (ISO 26262)
- › AURIX™ hardware encryption (HSM) enables advanced security features
- › Encapsulation feature allows software development without interference between multiple applications
- › Very high integrated functionality enables reduced board space
- › All features of a classic body control module are available, including protected load control with sophisticated diagnostics

Suggested products

Product family	Description
AURIX™	Scalable 32-bit TriCore™ microcontroller family from single to multicore (PRO-SIL™)
Supply ICs	Linear voltage regulators, DC-DC converters
SPIDER, HITFET™	Single- and multi-channel protected high- and low-side switches
LITIX™ Basic LED driver	Linear current sources for LED applications
Network transceiver	CAN, LIN, FlexRay transceiver
PROFET™, SPOC™	Single- and multi-channel protected high- and low-side switches
TDA52xx, TDK51xx, PMA51xx	Chipset for remote keyless entry and tire pressure monitoring applications



Low-cost body control module

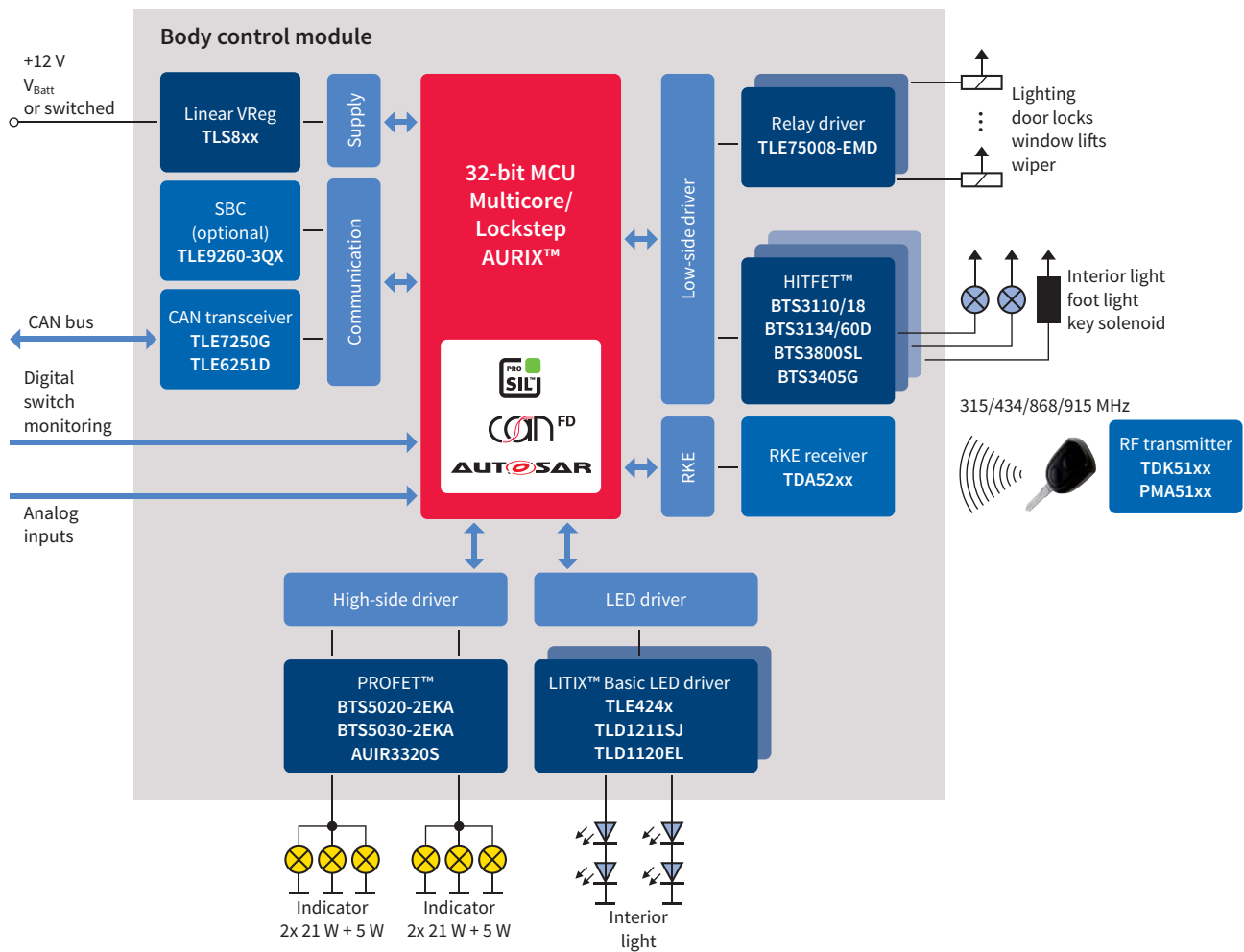

System benefits

- › Single low-cost module solution for the car body electronics
- › Scalability of the devices increases the reuse grade and design flexibility
- › Benchmark short-circuit robustness of power semiconductors improves system reliability (PROFET™)
- › Full integration of load protection and diagnostics reduces PCB area and improves the design quality

Suggested products

Product family	Description
AURIX™	Scalable 32-bit TriCore™ microcontroller family from single to multicore (PRO-SIL™)
Supply ICs	Linear voltage regulators, DC-DC converters
SPIDER, HITFET™	Single- and multi-channel protected high- and low-side switches
LITIX™ Basic LED driver	Linear current sources for LED applications
Network transceiver	CAN and LIN transceiver
PROFET™	Protected high-side switches
TDA52xx, TDK51xx	Chipset for remote keyless entry applications



Gateway

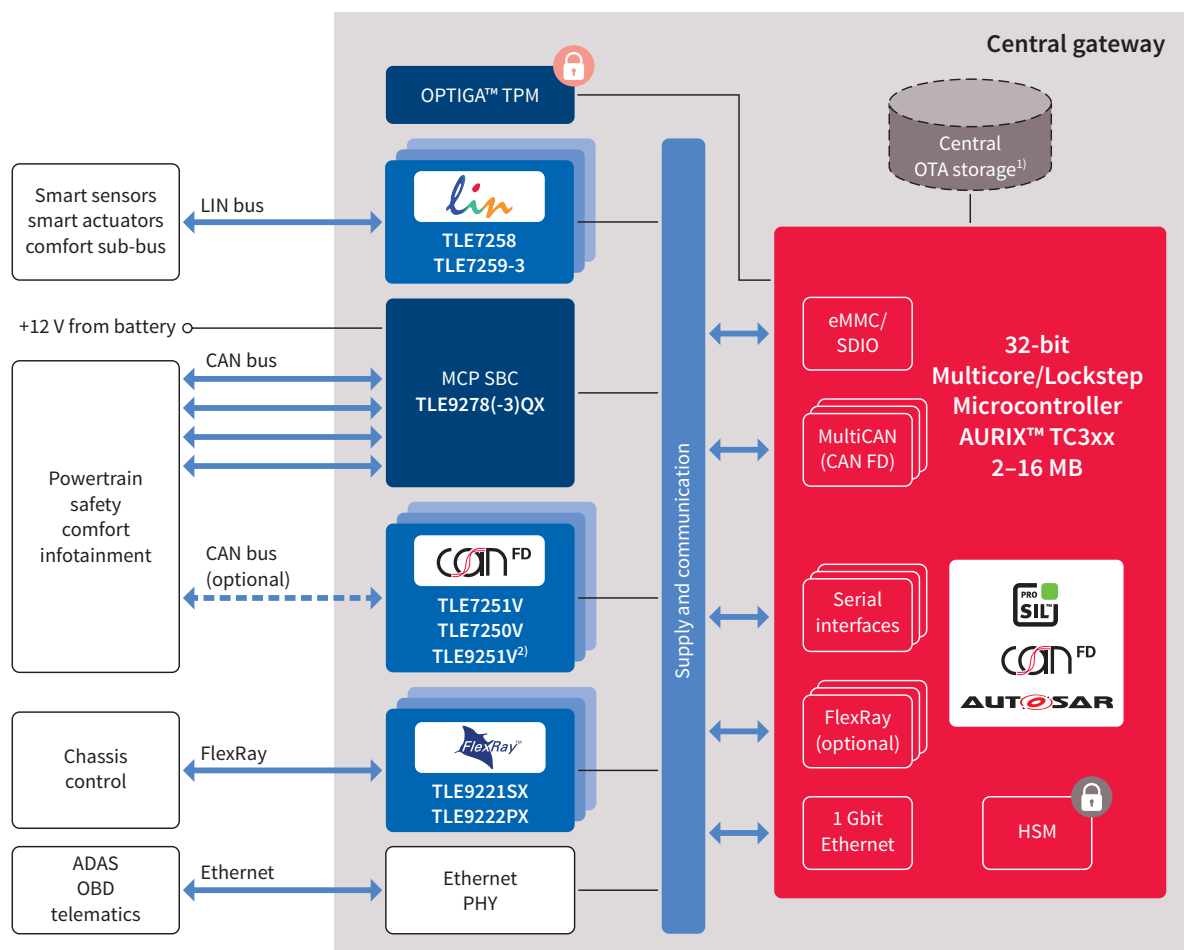

1) Depending of customer architecture, part of gateway, telematics etc.
 2) In development, samples available

System benefits

- > Enables pretended networking and ECU degradation
- > High integration leads to significant cost savings
- > High integration results in reduced complexity
- > ISO 26262 compliance supports ASIL requirements
- > Innovative supply concept leads to best-in-class power consumption

Suggested products

Product family	Description
AURIX™	Scalable 32-bit TriCore™ microcontroller family from single to multicore (PRO-SIL™)
Supply ICs	Linear voltage regulators, DC-DC converters
Network transceiver	CAN, LIN and FlexRay transceiver



HVAC control module

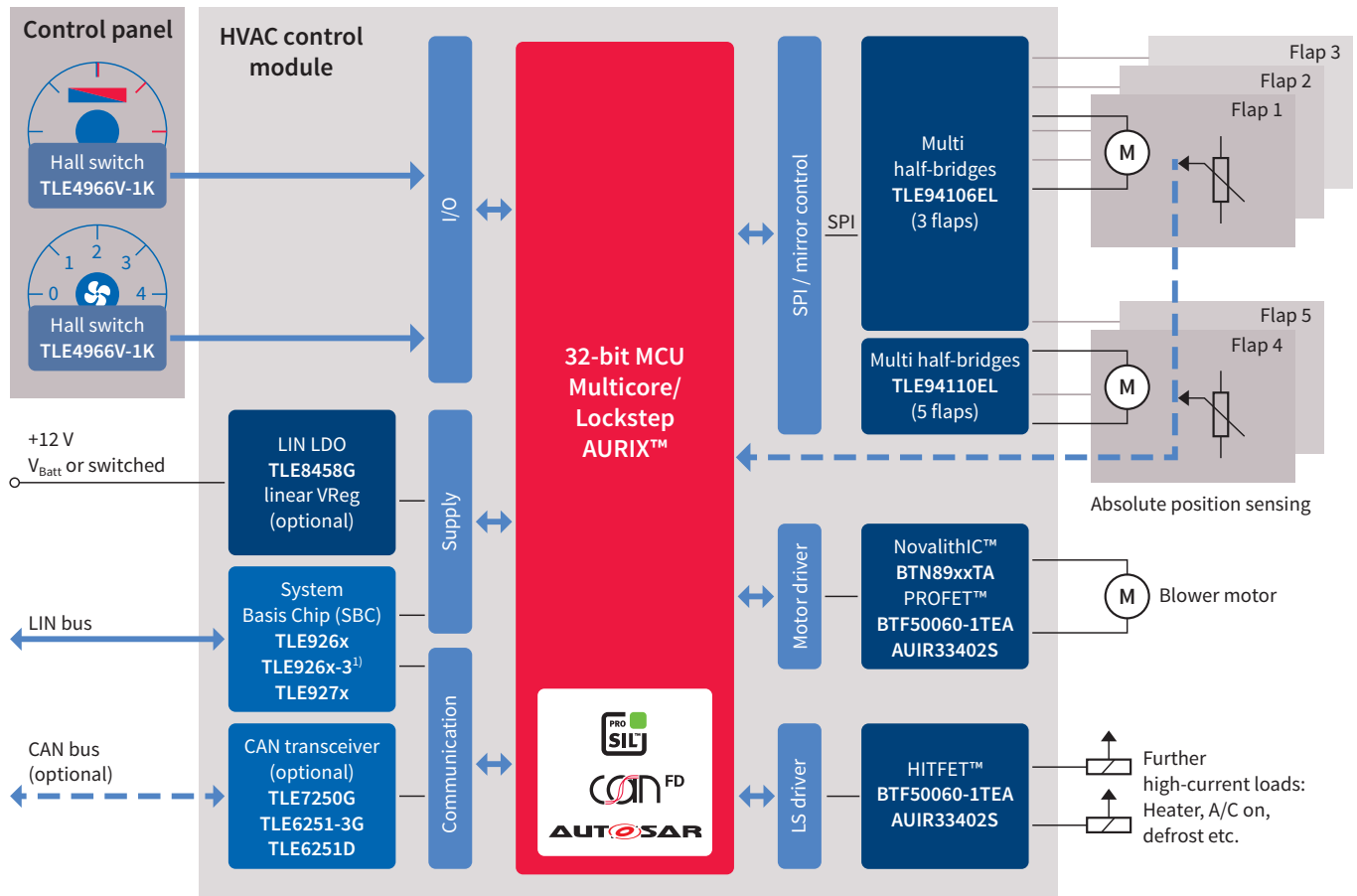

1) Supports CAN partial networking

System benefits

- > High-performance, scalable microcontroller family for various classes of HVAC control algorithms
- > Integrated motor control with diagnostics
- > Dedicated multi half-bridge devices for flap motor control with potentiometer feedback
- > Powerful half-bridge devices (NovalithIC™) with high-frequency PWM capability for the blower control

Suggested products



Product family	Description
AURIX™	Scalable 32-bit TriCore™ microcontroller family from single to multicore (PRO-SIL™)
Supply ICs	Linear voltage regulators, DC-DC converters
NovalithIC™, multi half-bridges	Integrated motor control. Powerful half-bridge devices (NovalithIC™) with high-frequency PWM capability for blower control.
Hall switches	Magnetic field sensors with a discrete output signal
PROFET™	Protected high-side switch
HITFET™	Protected low-side switches
LIN LDO, SBCs	Voltage regulators with LIN transceiver, system basis chips
Network transceiver	CAN and LIN transceiver

Decentralized front light module

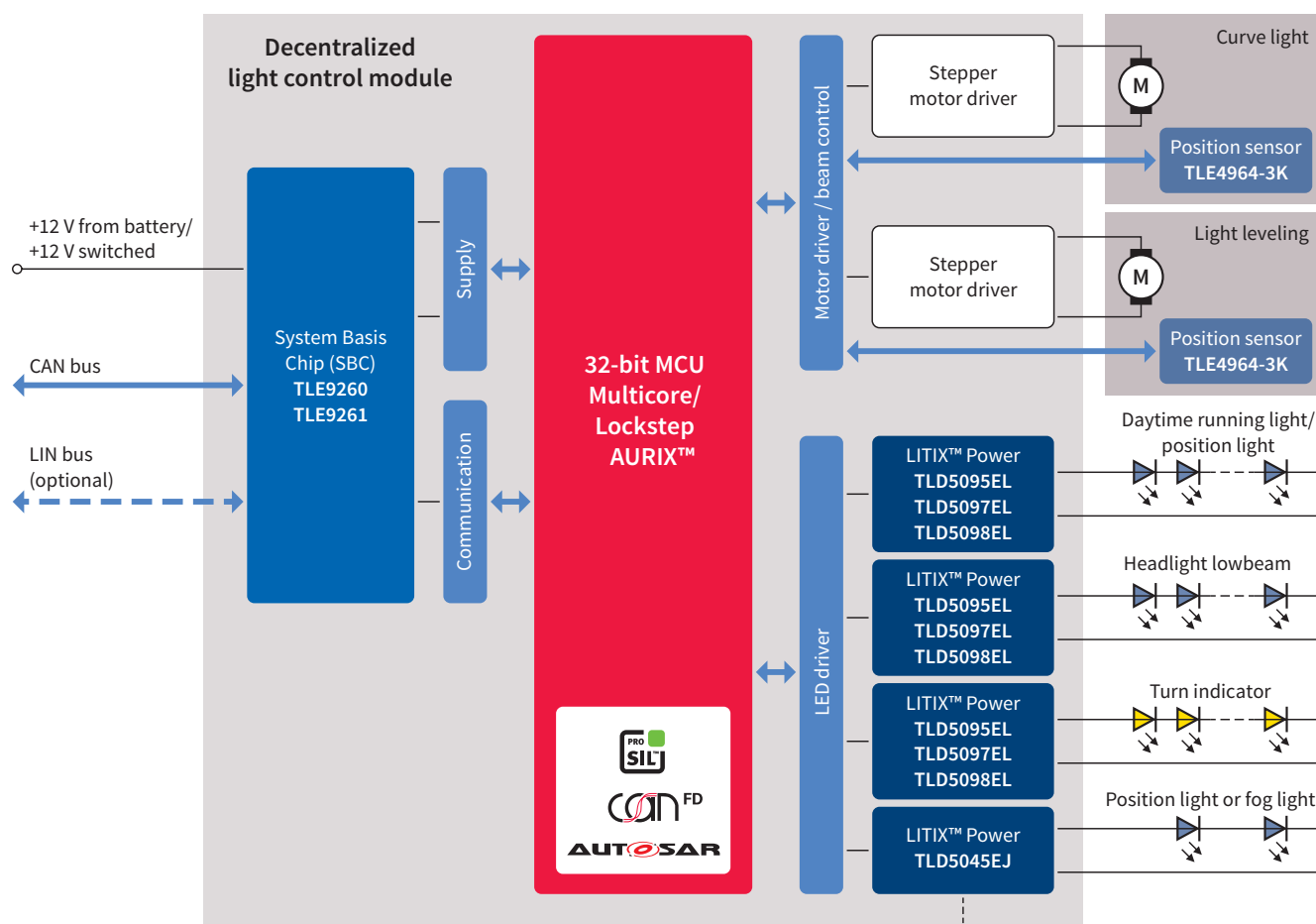

System benefits

- › Automotive LED drivers for high-brightness LEDs
- › LED driver ICs supporting various DC-DC topologies (buck, boost, SEPIC)
- › Microcontroller peripherals enable light control with a low CPU load
- › System basis chips combine supply, network transceiver and supervision functions in a monolithic device

Suggested products

Product family	Description
AURIX™	Scalable 32-bit TriCore™ microcontroller family from single to multicore (PRO-SIL™)
SBCs, network transceiver	System basis chips, CAN and LIN transceiver
LITIX™ Power LED driver	DC-DC converter and controller for high-power LED lighting
Supply ICs	Linear voltage regulators, DC-DC converters



LED rear light module

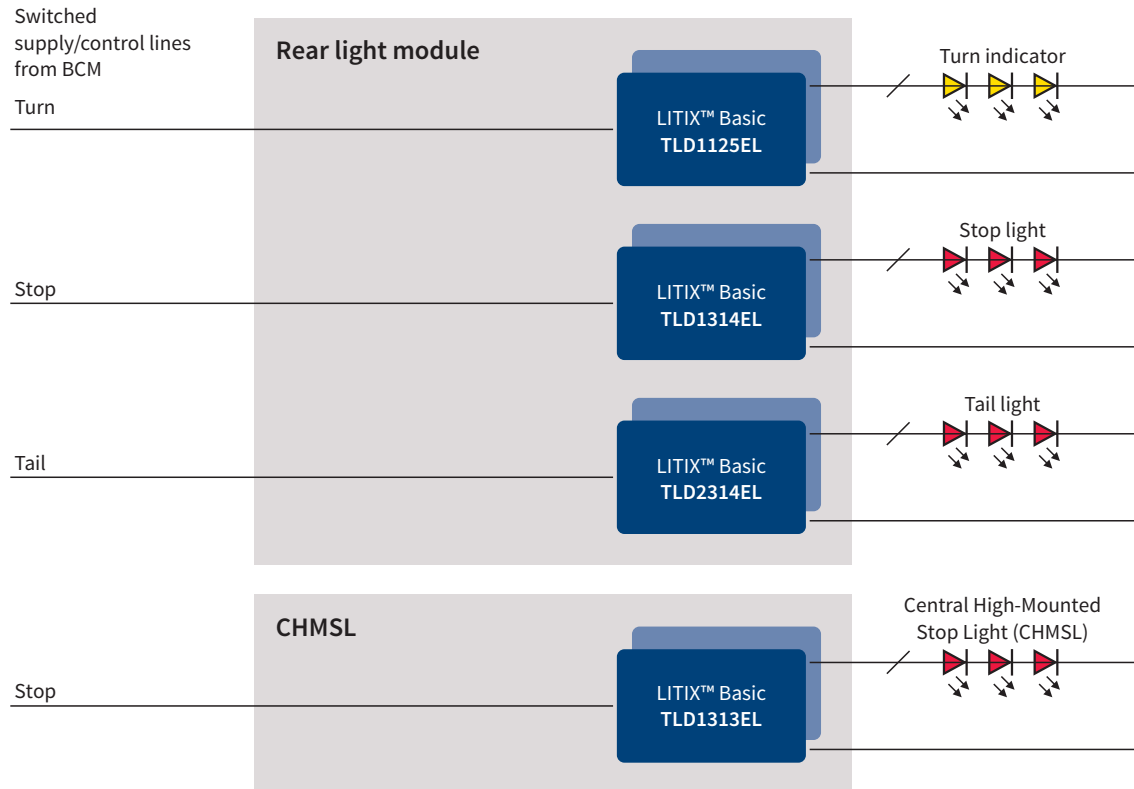

System benefits

- > Integrated LED control with diagnostic and dimming capability
- > Reduced system complexity and board space
- > Pin-to-pin footprint compatibility
- > Reduced outlay for design adaptations
- > Increased lifetime for LED and driver due to integrated protection

Suggested products

Product family	Description
LITIX™ Basic LED driver	Linear constant current sources with scalable feature set

Roof control module with interior and ambient light control

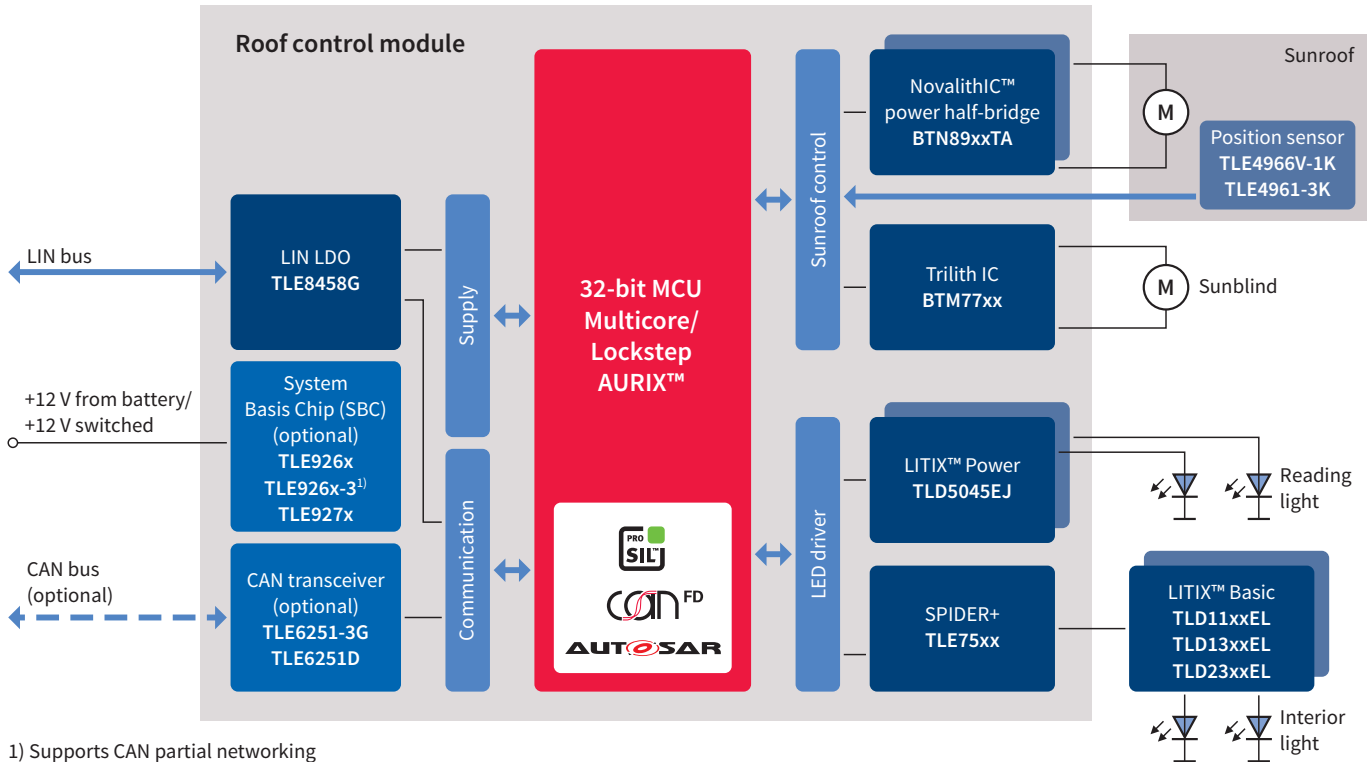

System benefits

- › Integrated motor control with diagnostics
- › Automotive LED drivers for high brightness LEDs
- › High-performance MCU supporting ripple count algorithms
- › Dedicated LIN slave devices for RGB ambient lighting

Suggested products



Product family	Description
AURIX™	Scalable 32-bit TriCore™ microcontroller family from single to multicore (PRO-SIL™)
LIN LDO, SBCs	Voltage regulators with LIN transceiver, system basis chips
Network transceiver	CAN and LIN transceiver
LIN LED driver	Smart LED control system-on-chip for multi-color and RGB lighting
LITIX™ Power LED driver	DC-DC converter and controller for high-power LED lighting
Trilith IC, NovalithIC™	Integrated motor control devices with diagnostics
SPIDER	Multi-channel protected high- and low-side switches
Hall switches	Magnetic field sensors with a discrete output signal
Supply ICs	Linear voltage regulators, DC-DC converters

Interior light control with capacitive touch sensor

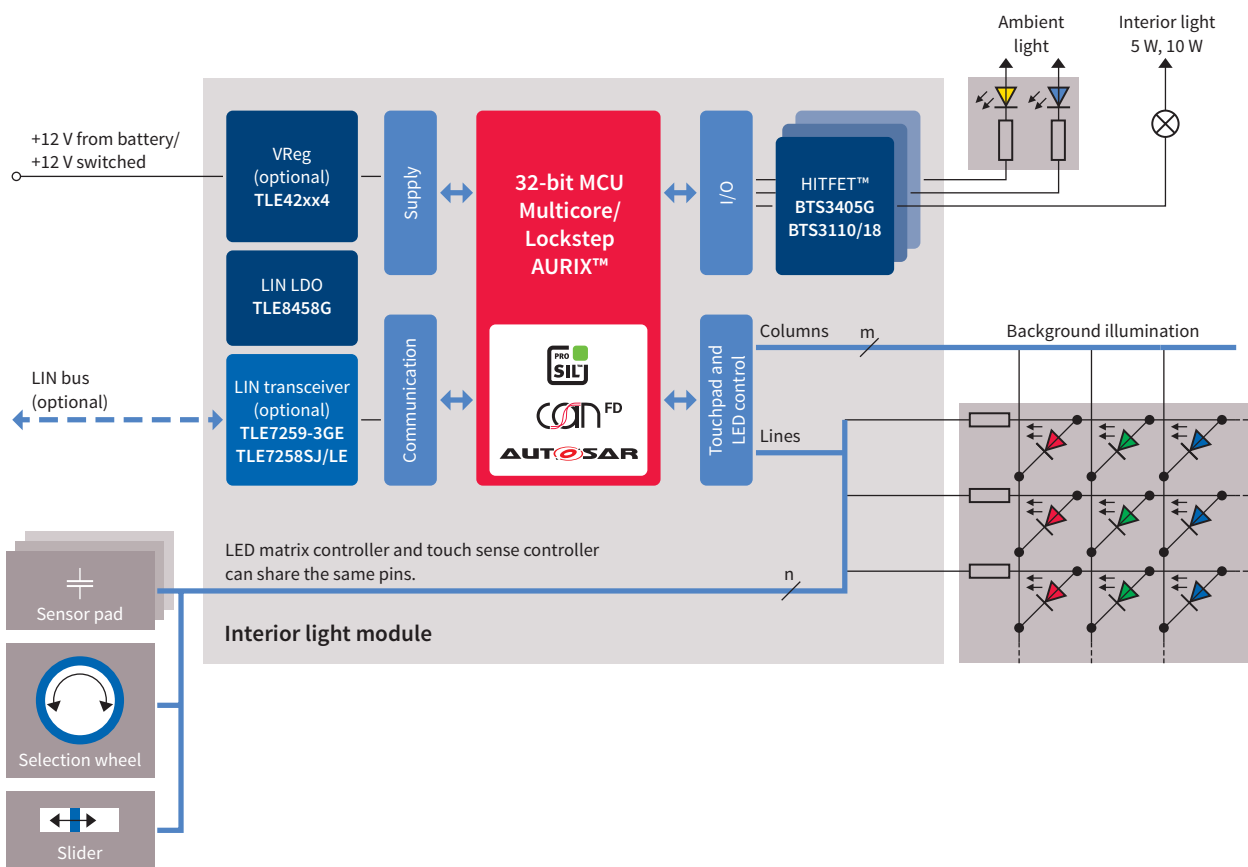

System benefits

- › Replacing mechanical switches offers high system cost savings
- › Robust and reliable touch sense control technology, especially in noisy environments in combination with multiple coverage options such as acrylic glass (~2 mm)
- › Enables the efficient design of HMIs with up to 20 touch buttons
- › Low pin count and cheap single-layer PCB solutions
- › High feature integration: combined control and drive of displays or stepper motors with up to 50 mA
- › Easy and flexible implementation: optimized SW library for touch sense control in ROM frees up flash memory and CPU resources for customer-specific solutions

Suggested products

Product family	Description
AURIX™	Scalable 32-bit TriCore™ microcontroller family from single to multicore (PRO-SIL™)
Supply ICs	Linear voltage regulators, DC-DC converters
Network transceiver	LIN and CAN transceivers
LIN LDO	Voltage regulator with integrated LIN transceiver
HITFET™	Smart low-side switches



Power distribution for start-stop systems with a dual-battery approach

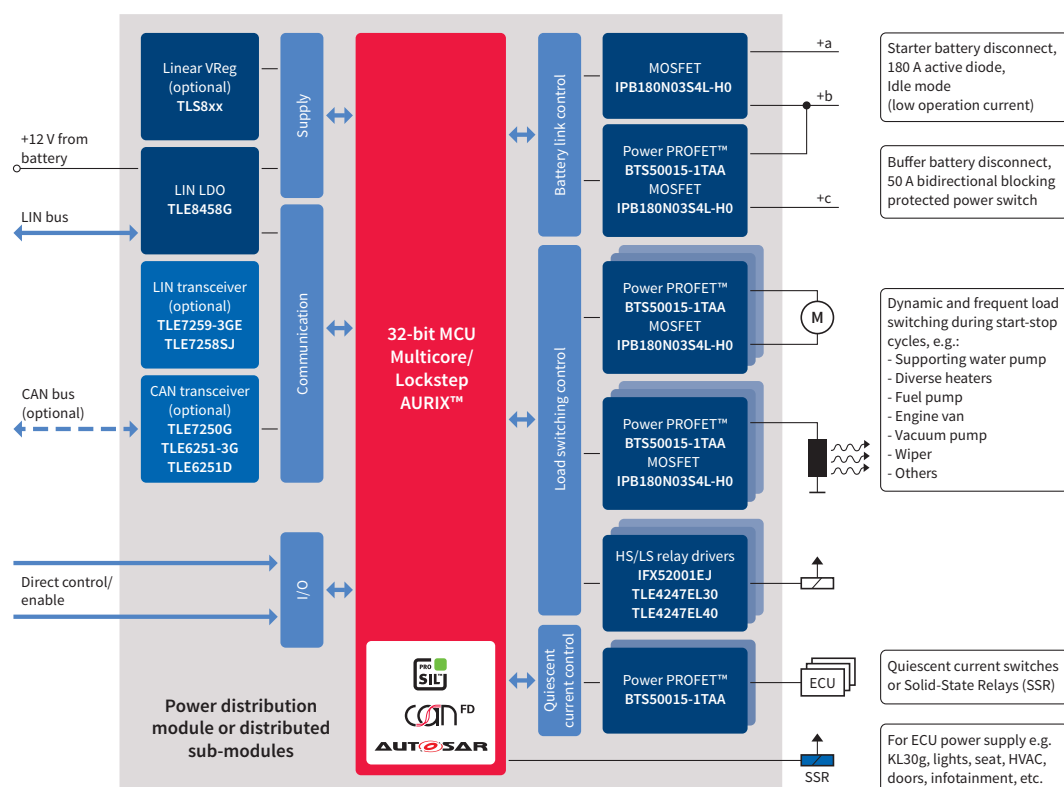

System benefits

- › Smart high-current, high-power switching
- › Solid-state power switch provides relay functionality with alternative fuse
- › Low power losses due to extremely efficient low-ohmic devices
- › Alternative protection modes: smart or fuse protection
- › Some power switches with current input control for long control wires
- › Sophisticated diagnostic features
- › High number of switching activations, negligible aging
- › Bidirectional blocking power switches
- › Active diode functionality
- › Solid-state relay (power switch inside relay housing)
- › Smart relay driver, optional with constant current control

Suggested products

Product family	Description
AURIX™	Scalable 32-bit TriCore™ microcontroller family from single to multicore (PRO-SIL™)
Supply ICs	Linear voltage regulators, DC-DC converters
LIN LDO, network transceiver	System basis chips, LIN and CAN transceivers
Power PROFET™	BTS500xx protected power high-side switch
SPIDER	Protected multi-channel high-side and low-side switches
TLE4247	Constant current relay driver
SSR	Solid-state relay (power switch inside relay housing)
OptiMOS™-T2 IPBxxS4	Automotive trench power MOSFET



Seat control module

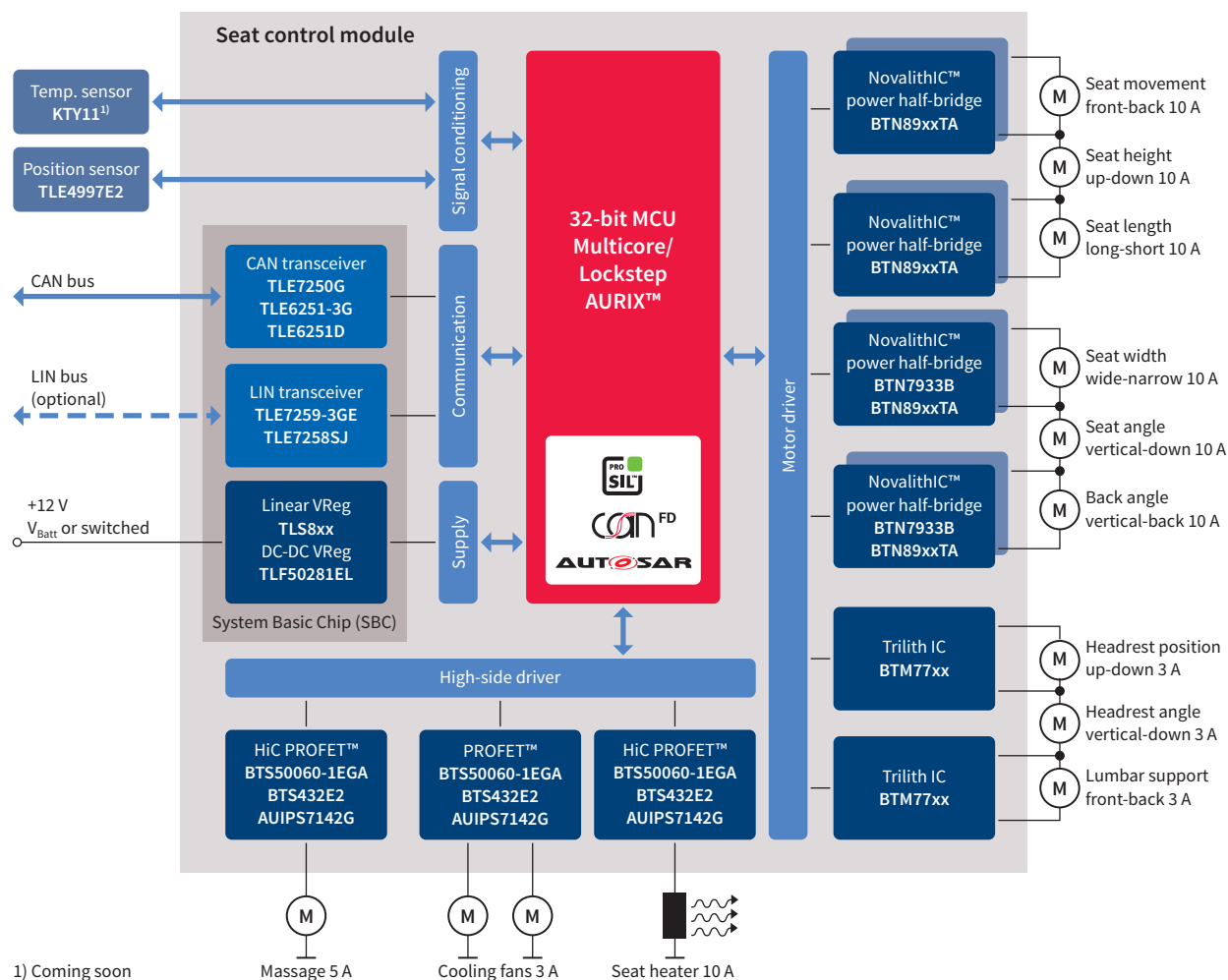

1) Coming soon

System benefits

- > System-in-a-package solutions for high-power integrated and protected motor control
- > Reduced board space due to integrated functionality
- > Protected load control with sophisticated diagnostic features

Suggested products



Product family	Description
AURIX™	Scalable 32-bit TriCore™ microcontroller family from single to multicore (PRO-SIL™)
Supply ICs	Linear voltage regulators, DC-DC converters
SBCs, network transceiver	System basis chips, CAN and LIN transceivers
PROFET™	Protected high-side switches
NovalithIC™, Trilith IC	Integrated motor control solutions with diagnostics
Linear Hall sensors	Magnetic field sensors with a linear output signal

Decentralized mirror module

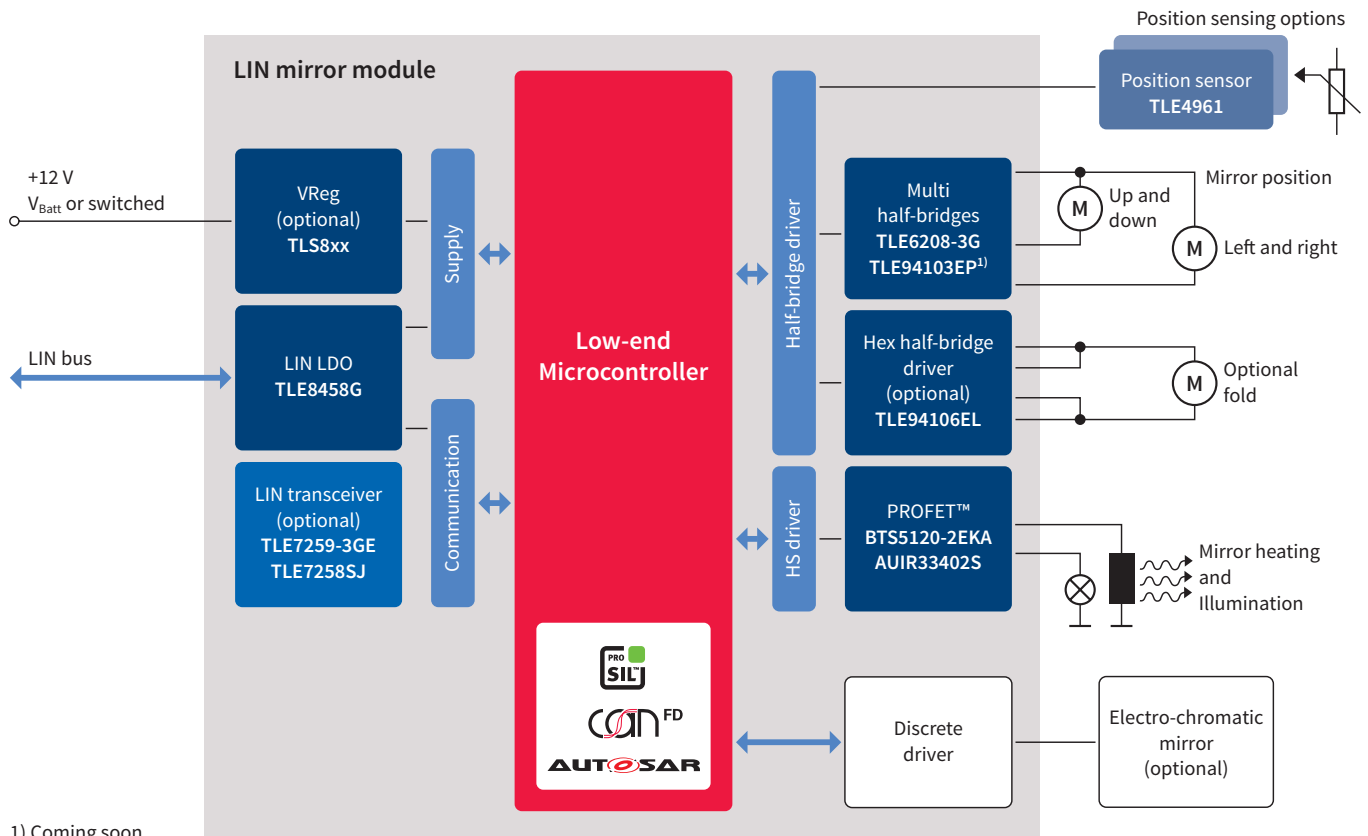

System benefits

- > Low power consumption, as well as low quiescent current
- > Excellent price-performance ratio
- > Space-saving devices for integrated motor control (mirror x/y adjustment, optional fold feature)

Suggested products



Product family	Description
LIN LDO, network transceiver	CAN and LIN transceiver
PROFET™	Protected high-side switches
Multi half-bridges	Integrated motor control
Hall switches	Magnetic field sensors with discrete output signal
Supply ICs	Linear voltage regulators, DC-DC converters

Smart window lift/roof control module

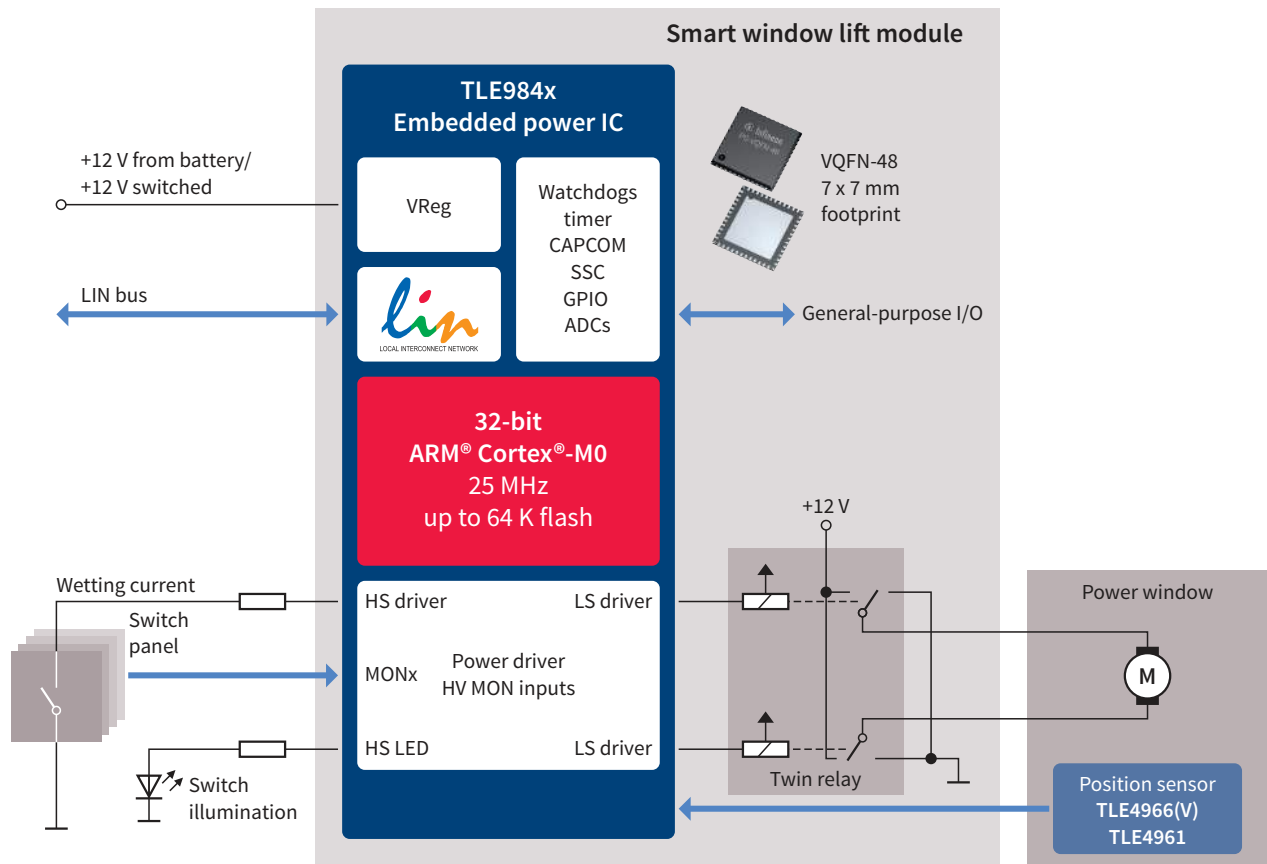

System benefits

- > System-on-chip solution with integrated ARM® Cortex®-M0 industry-standard microcontroller core
- > Platform solution for a size- and weight-optimized relay-based motor control
- > Integrated voltage regulator, LIN transceiver, switch inputs and relay driver
- > Cyclic sense and cyclic wake-up capability reduces average current consumption
- > Package with a very small form factor saves PCB board space
- > Single-chip solution improves module reliability

Suggested products

Product name	Description
TLE984x	Motor driver IC for external relays with an integrated ARM® Cortex®-M0 MCU
TLE496x	Hall switches – magnetic field sensors with a discrete output signal

System-on-chip 3-phase motor control

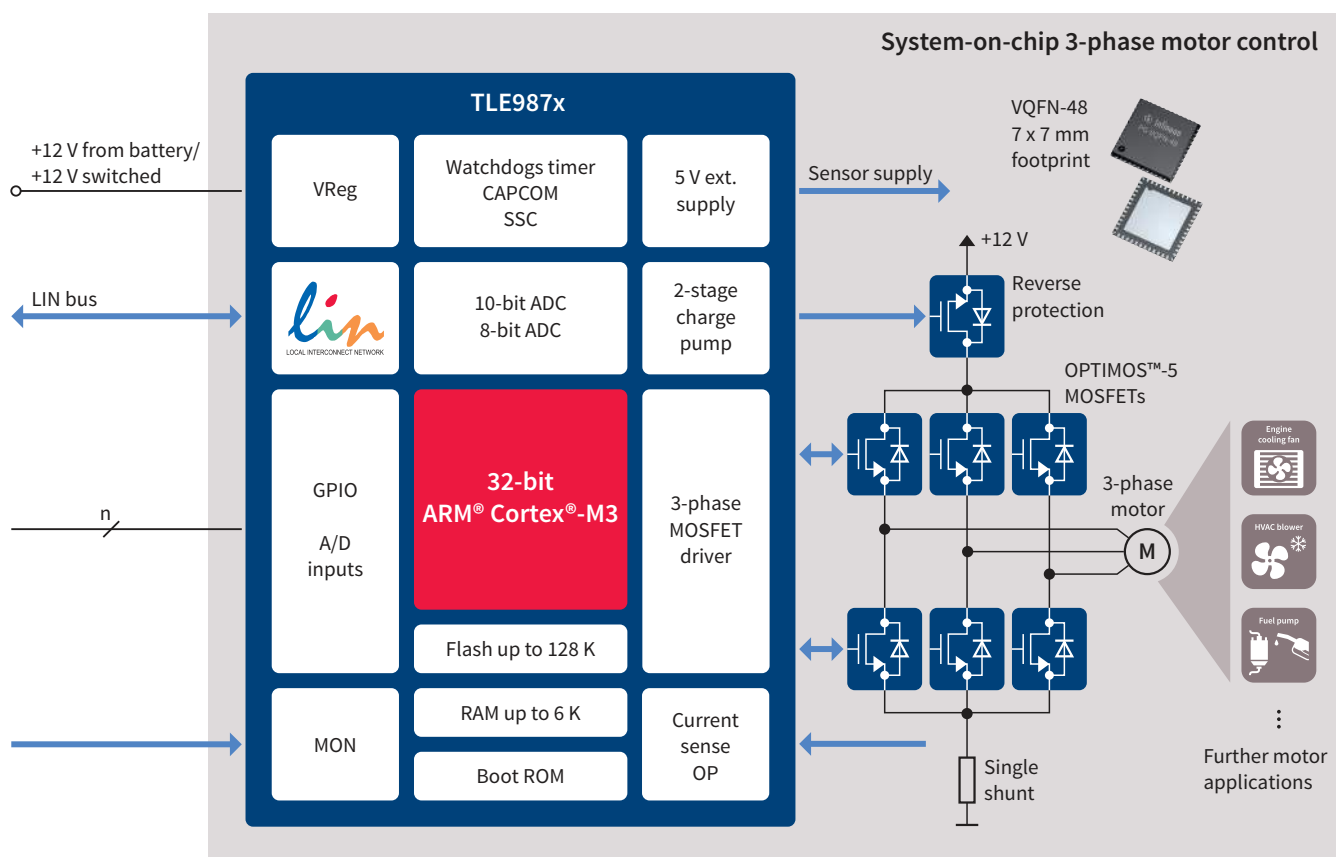

System benefits

- › System-on-chip solution with an integrated ARM® Cortex®-M3 industry-standard microcontroller core
- › Platform solution for a wide range of size- and weight-optimized motor applications
- › Package with a very small form factor saves PCB board space
- › Integrated voltage regulator, LIN transceiver, switch input and direct control of N-Channel MOSFETs
- › Configurable MOSFET driver simplifies EMC design
- › Supports various motor control algorithms including sensorless control
- › Integrated intelligent power-saving modes and energy management
- › Single-chip solution improves module reliability

Suggested products

Product name	Description
TLE987x	3-phase motor driver with an Integrated ARM® Cortex®-M3 MCU
OptiMOS™-T2 IPBxxS4	Automotive trench power MOSFET



Powertrain applications

The powertrain market is driven by the need to reduce the carbon footprint of cars via affordable, efficiency-enhancing innovations. Concrete measures include rightsizing engines, improving fuel injection accuracy and increasing after-treatment efficiency. On the transmission side, car-makers are looking to optimize both the gear ratio and gear shifting. Other efficiency-enabling activities include reducing friction and hydraulic losses. In a more general context, the drive for greater ecology on the roads is pushing the transition toward vehicle electrification and hybridization.

As one of the largest automotive semiconductor suppliers, Infineon has been active in the powertrain electronic business for over 40 years. Our position as innovation leader, coupled with long-term partnerships with OEMs, Tier 1 and engineering service providers, means we reap the benefits of in-depth system expertise and broad application competence. Infineon delivers an extensive range of optimized,

competitive and scalable powertrain products and chipset solutions. Our portfolio covers the full sensor spectrum from position, over angle and speed to barometric and manifold pressure, supplemented by a strong 8-bit, 16-bit and 32-bit powertrain microcontroller portfolio. In addition to the necessary power components, such as voltage supplies, MOSFETs and IGBTs, smart low-side and high-side switches, CAN/LIN and FlexRay transceivers, the product range is rounded off by a multitude of highly integrated automotive system ICs, such as engine management ICs, alternator regulators, System Basis Chips (SBC) and constant current control ICs for transmission control.

With regard to the ongoing electrification and hybridization of the drivetrain, we actively support our customers with reference solutions for the charger and DC-DC, as well as inverter systems.

48 V micro-hybrid

(start/stop and high-efficiency generator)

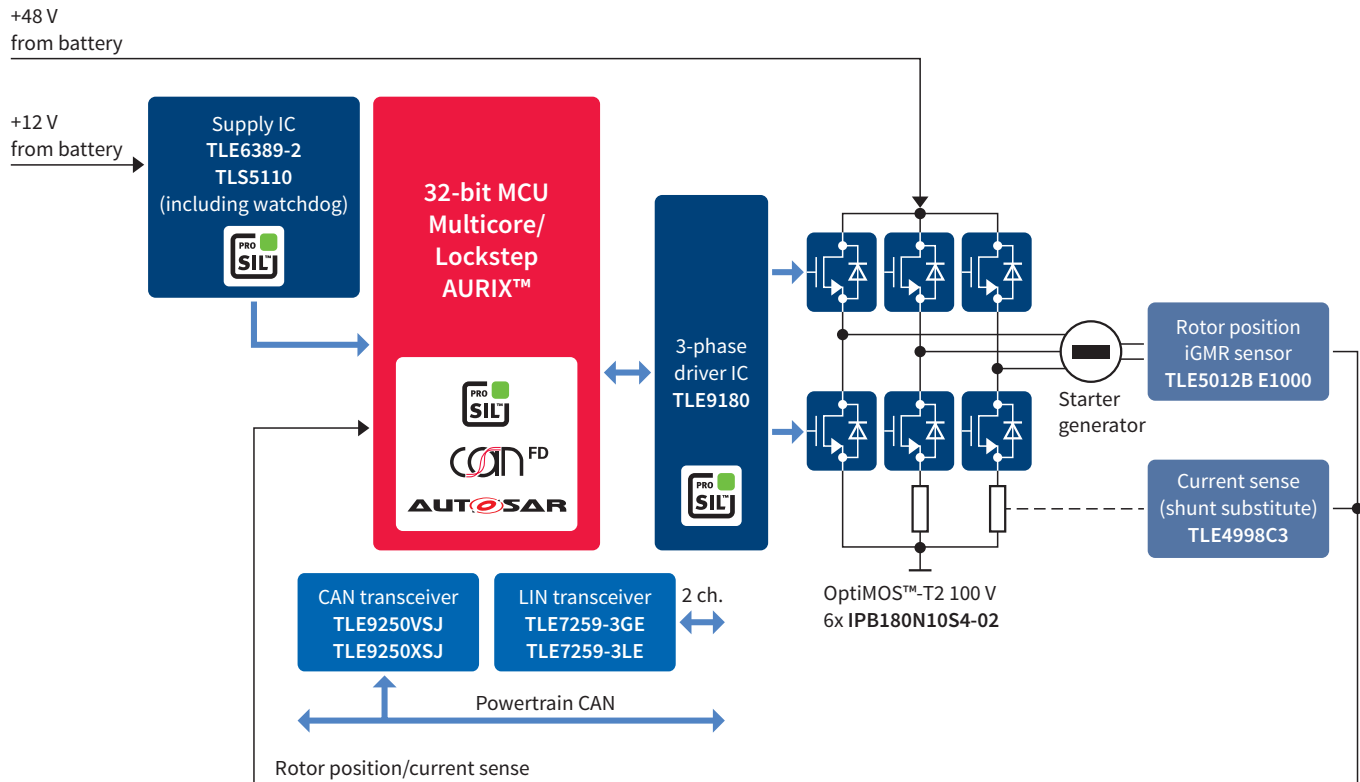

System benefits

- › Full range of products ranging from voltage regulators, transceivers, sensors, microcontrollers and smart power drivers
- › Leading-edge OptiMOS™ MOSFET technology combined with a robust package for ensuring best-in-class performance and outstanding current capacity
- › Higher alternator efficiency thanks to MOSFET rectification
- › Higher output current at low alternator RPM
- › Advanced modes supported: engine brake emulation, car sailing/coasting, electrical car launch

Suggested products



Product name	Description
AURIX™	Cost-optimized TriCore™ 32-bit microcontroller with dedicated motor control features (PRO-SIL™)
TLE9180	3-phase bridge driver IC (PRO-SIL™)
TLE9250VSJ/XSJ	CAN (Control Area Network) serial bus transceiver with multi-master capabilities for data communication in harsh environments, supporting Flexible Data-rate (CAN FD)
TLE7259-3GE/-3LE	LIN (Local Interconnect Network) bus for local communication between actuators, sensors or switches and an ECU
TLE6389-2, TLS5110	DC-DC converters
TLS20x	Linear post regulators
OptiMOS™	N-channel 100 V MOSFET, optimized for high-current motor applications
TLE499x	Linear Hall sensor family for current sensing
TLE5012B	iGMR sensor for angle and rotor position sensing

Automatic transmission – hydraulic control

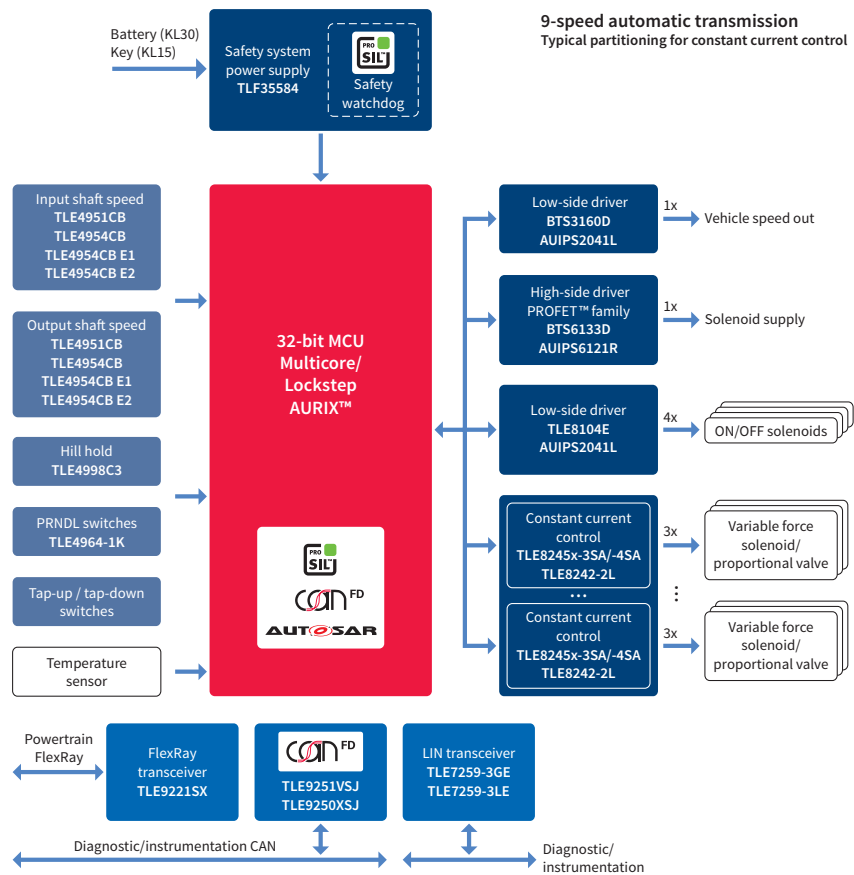

System benefits

- › Full range of products ranging from voltage regulators, transceivers, sensors, microcontrollers and smart power drivers
- › Valve actuator ICs supporting the ultimate in precision current control
- › Optimized sensors providing enhanced disturbance immunity (e.g. vibration) and direction detection
- › High-temperature bare die IC supporting integrated transmission control up to the highest torque rate

Suggested products



Product name	Description
AURIX™	32-bit multicore TriCore™ microcontroller family, optimized for highly demanding powertrain applications (PRO-SIL™)
TLF35584	High-efficiency system power supply (PRO-SIL™)
TLE8245x-3SA/-4SA/ TLE8242-2L	Integrated transmission ICs for precise variable force or constant current solenoid control
PROFET™	Smart high-side switches
TLE495x	Precise and robust speed sensing
TLE499x/TLE496x	Robust and flexible position sensing
Low-side driver	Smart low-side power switches in single- or multi-channel configuration. Applicable product families: HITFET, FLEX, IPS.
LIN transceiver	LIN (Local Interconnect Network) bus for local communication between actuators, sensors or switches and an ECU
CAN FD transceiver	CAN (Control Area Network) serial bus transceiver with multi-master capabilities for data communication in harsh environments, supporting Flexible Data-rate (CAN FD)
FlexRay transceiver	FlexRay: serial, deterministic bus transceiver for real-time control applications
TLE425x, TLS1xx	Linear-voltage trackers for supplying sensors

Double-clutch transmission – hydraulic control

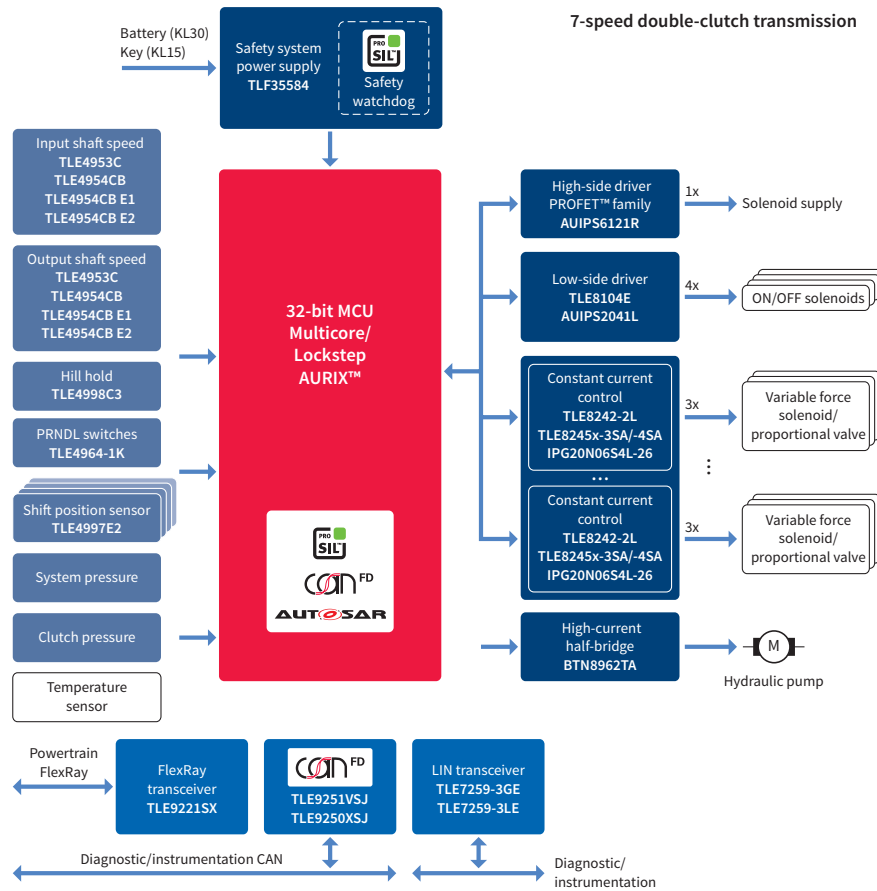

System benefits

- > Full range of products ranging from voltage regulators, transceivers, sensors, microcontrollers and smart power drivers
- > Valve actuator ICs supporting the ultimate in precision current control
- > Optimized sensors providing enhanced disturbance immunity (e.g. vibration) and direction detection
- > High-temperature bare die IC supporting integrated transmission control up to the highest torque rate
- > Coherent chipset solution for an easy and effective ISO 26262-compliant system implementation

Suggested products



Product name	Description
AURIX™	32-bit multicore TriCore™ microcontroller family, optimized for highly demanding powertrain applications (PRO-SIL™)
TLF35584	High-efficiency system power supply (PRO-SIL™)
TLE8245x-3SA/-4SA/ TLE8242-2L	Integrated transmission ICs for precise variable force or constant current solenoid control
PROFET™	Smart high-side switches
IPG20N06S4L-26	Dual N-Channel 60 V MOSFET in a super SO8 package, offering significant PCB board space savings
TLE495x	Precise and robust speed sensing
TLE499x/TLE496x	Robust and flexible position sensing
BTN8962TA	Single high-current half-bridge driver for motor control
CAN transceiver	CAN (Control Area Network) serial bus transceiver with multi-master capabilities for data communication in harsh environments, supporting Flexible Data-rate (CAN FD)
FlexRay transceiver	FlexRay: serial, deterministic bus transceiver for real-time control applications
LIN transceiver	LIN (Local Interconnect Network) bus for local communication between actuators, sensors or switches and an ECU
Low-side driver	Smart low-side power switches in single- or multi-channel configuration. Applicable product families: FLEX, IPS.
TLE425x, TLS1xx	Linear-voltage trackers for supplying sensors

Double-clutch transmission – electrical control

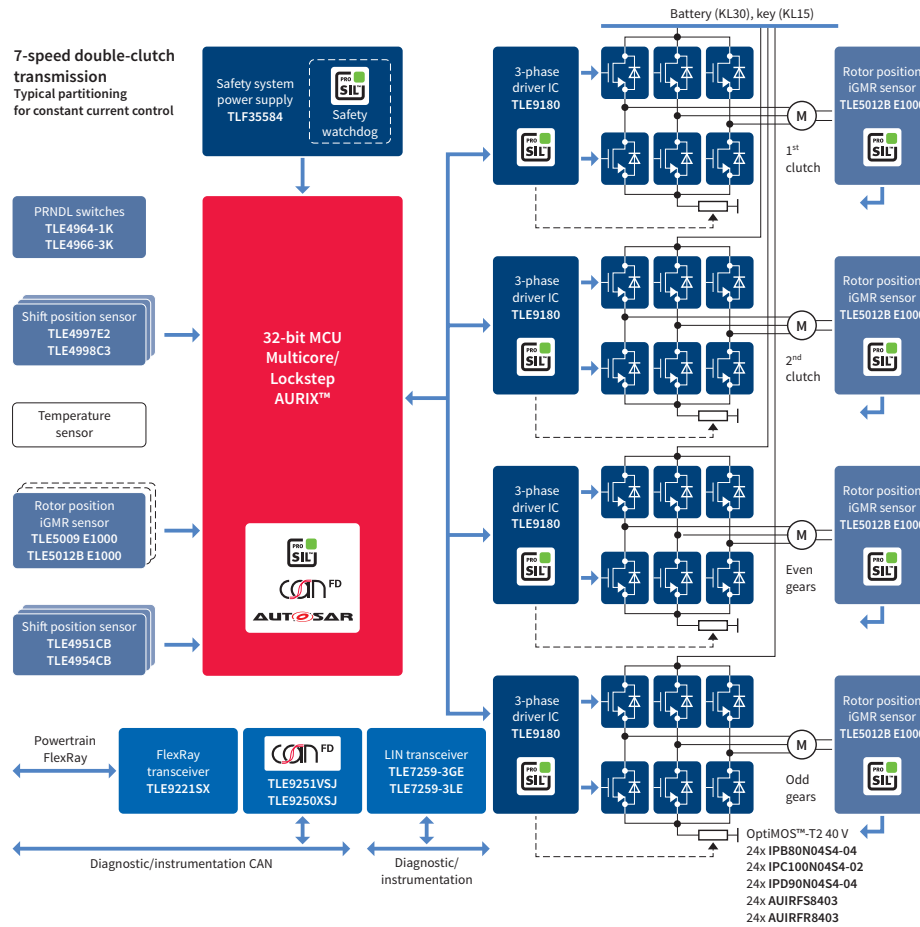

System benefits

- › Full range of products ranging from voltage regulators, transceivers, sensors, microcontrollers and smart power drivers
- › Leading-edge OptiMOS™-T2 MOSFET technology combined with a robust package for ensuring best-in-class performance and outstanding current capacity
- › Optimized sensors providing enhanced disturbance immunity (e.g. vibration) and direction detection
- › Reduces fuel consumption compared to manual transmission
- › Coherent chipset solution for an easy and effective ISO 26262-compliant system implementation

Suggested products

Product name	Description
AURIX™	32-bit multicore TriCore™ microcontroller family, optimized for highly demanding powertrain applications (PRO-SIL™)
TLF35584	High-efficiency system power supply (PRO-SIL™)
TLE9180	3-phase bridge driver IC (PRO-SIL™)
OptiMOS™-T2 40 V	N-channel OptiMOS™-T2 40 V MOSFET family, optimized for high-current motor applications
TLE5012B	iGMR sensor for angle and rotor position sensing
TLE499x/TLE496x	Robust and flexible position sensing
TLE495x	Precise and robust speed sensing
FlexRay transceiver	FlexRay: serial, deterministic bus transceiver for real-time control applications
LIN transceiver	LIN (Local Interconnect Network) bus for local communication between actuators, sensors or switches and an ECU
CAN transceiver	CAN (Control Area Network) serial bus transceiver with multi-master capabilities for data communication in harsh environments, supporting Flexible Data-rate (CAN FD)
TLE425x, TLS1xx	Linear-voltage trackers for supplying sensors



Gasoline multi-port injection – discrete solution

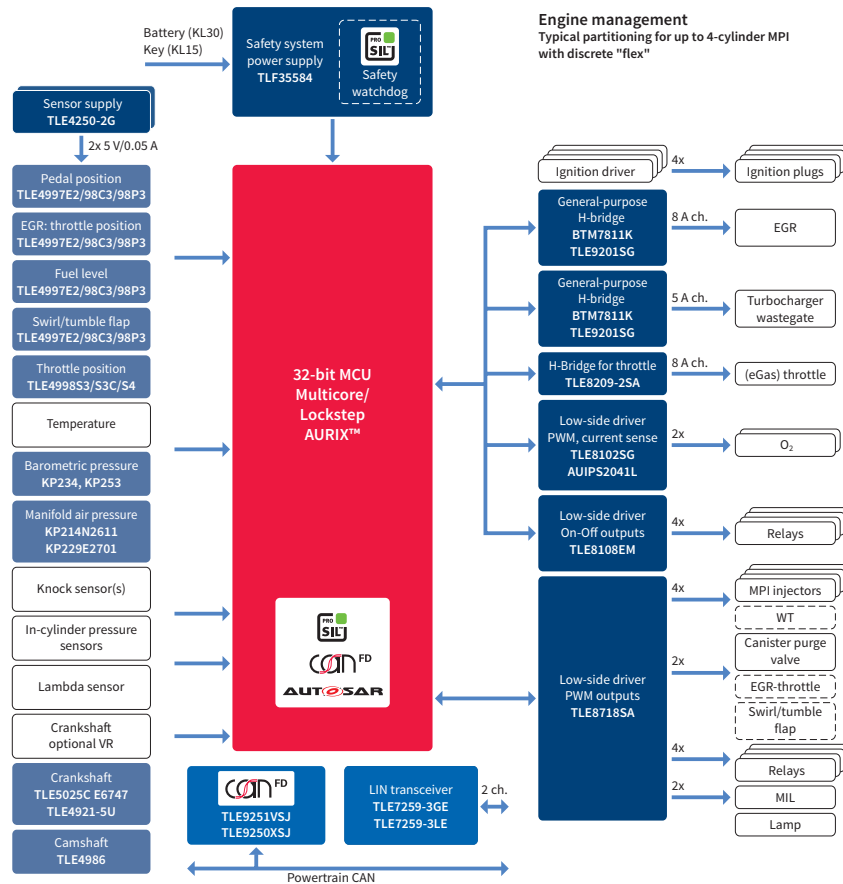

System benefits

- > Flexible and scalable product portfolio tailored to the cost and performance needs of the mid-end and entry segments
- > Industry benchmark in embedded real-time performance facilitates pumping loss reduction, knock detection and efficient after-treatment
- > Conforming with upcoming emission legislation while delivering maximum fuel efficiency and even more driving pleasure, the new sensor families provide enhanced measurement precision (e.g. ignition control, misfire detection)

Suggested products

Product name	Description
AURIX™	32-bit multicore TriCore™ microcontroller family, optimized for highly demanding powertrain applications (PRO-SIL™)
CAN transceiver	CAN (Control Area Network) serial bus transceiver with multi-master capabilities for data communication in harsh environments, supporting Flexible Data-rate (CAN FD)
TLE8209-2SA	Electronic Throttle Control (ETC) driver
TLE9102SG	New cost-efficient H-bridge driver for non-ETC use cases, such as exhaust gas recirculation (EGR), turbocharger wastegate, turbocharger geometry and other DC motor driver actuators
TLE4250-2G	Linear-voltage tracker for independent sensor supply
TLF35584	High-efficiency system power supply (PRO-SIL™)
TLE50xx, TLE49xx, KP2xx	Broad portfolio of pressure sensors (MAP and BAP) as well as magnetic cam- and crankshaft and position sensors
KP27x	Sensor with a digital SENT interface in development
Low-side driver	Smart low-side power switches in single- or multi-channel configuration. Applicable product families: FLEX, IPS.
LIN transceiver	LIN (Local Interconnect Network) bus for local communication between actuators, sensors or switches and an ECU
TLE425x, TLE1xx	Linear-voltage trackers for supplying sensors



Gasoline multi-port injection – integrated solution

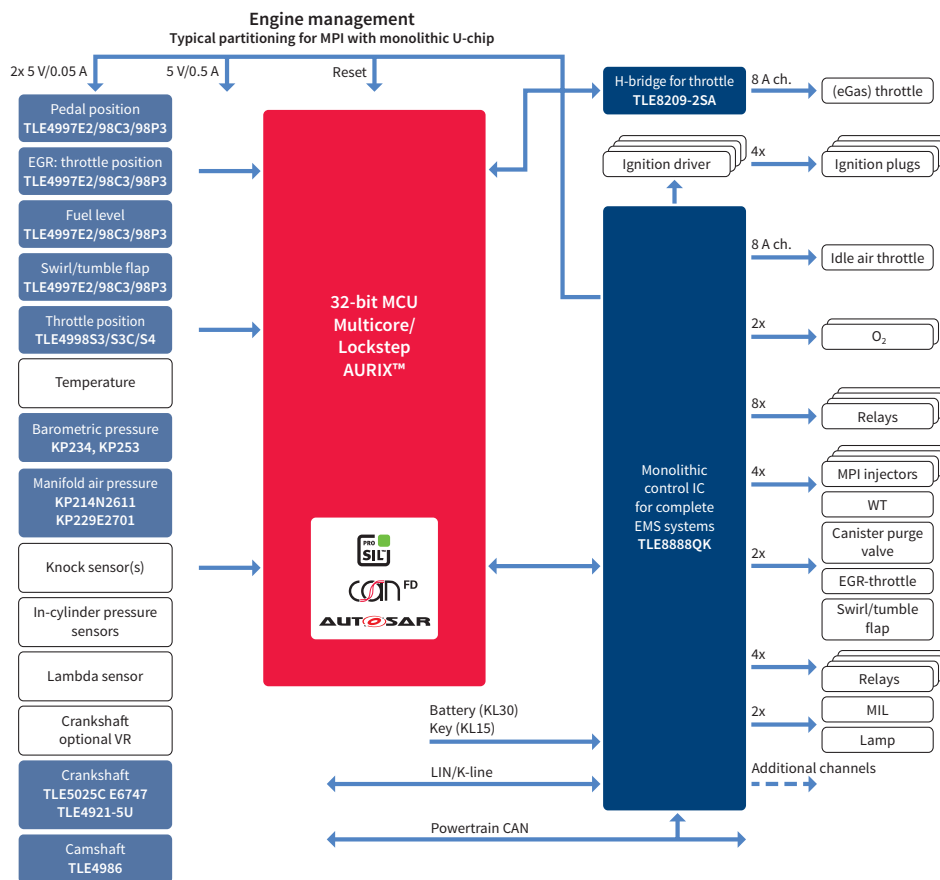

System benefits

- > Highest degree of integration resulting in minimized board space, optimized thermal performance and cost
- > Industry benchmark in embedded real-time performance facilitates pumping loss reduction, knock detection and efficient after-treatment
- > Conforming with upcoming emission legislation while delivering maximum fuel efficiency and even more driving pleasure, the new sensor families provide enhanced measurement precision (e.g. ignition control, misfire detection)

Suggested products

Product name	Description
AURIX™	32-bit multicore TriCore™ microcontroller family, optimized for highly demanding powertrain applications (PRO-SIL™)
TLE8888QK	Monolithic control IC for complete EMS systems
TLE8209-2SA	Electronic Throttle Control (ETC) driver
TLE50xx, TLE49xx, KP2xx	Broad portfolio of pressure sensors (MAP and BAP) as well as magnetic cam- and crankshaft and position sensors
KP27x	Sensor with a digital SENT interface in development
TLE425x, TLS1xx	Linear-voltage trackers for supplying sensors



Gasoline direct injection

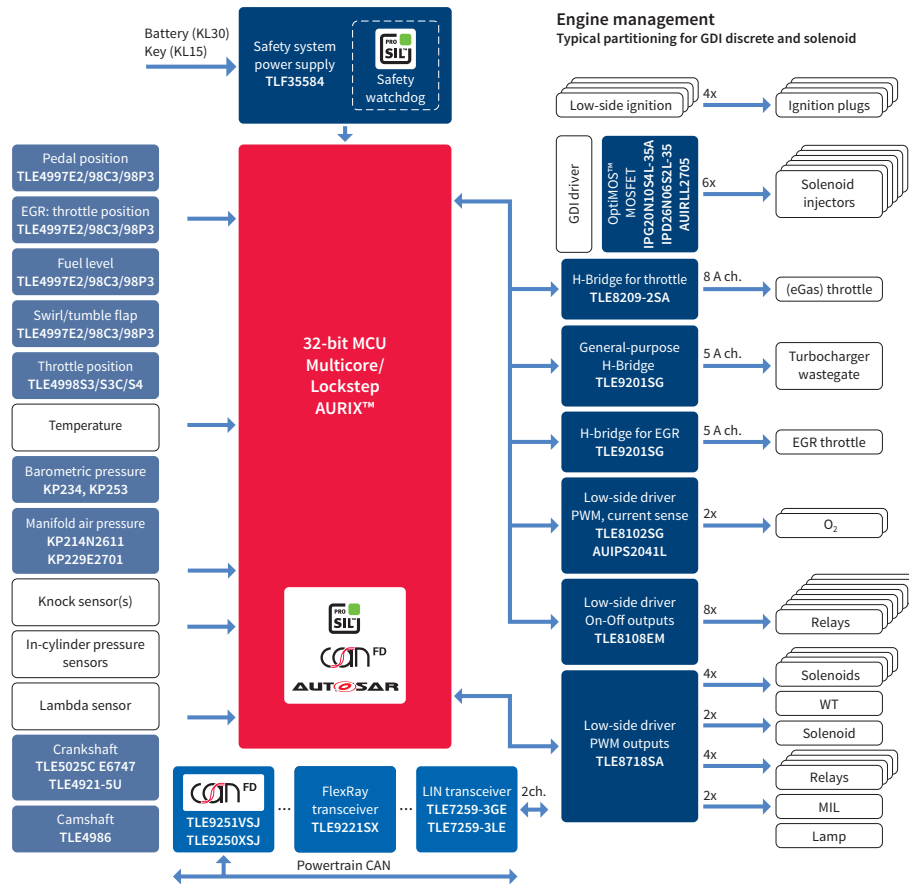

System benefits

- > Flexible and scalable product portfolio tailored to the performance and real-time needs of the premium and value segments
- > Conforms with the latest emission legislation while delivering the highest possible fuel efficiency and even more driving pleasure
- > Benchmark-setting real-time performance facilitates down-sizing, direct injection, turbocharging and highly efficient after-treatment
- > New sensor families provide enhanced measurement precision (e.g. ignition control, misfire detection)

Suggested products



Product name	Description
AURIX™	32-bit multicore TriCore™ microcontroller family, optimized for highly demanding powertrain applications (PRO-SIL™)
TLF35584	High-efficiency system power supply (PRO-SIL™)
CAN transceiver	CAN (Control Area Network) serial bus transceiver with multi-master capabilities for data communication in harsh environments, supporting Flexible Data-rate (CAN FD)
TLE8209-2SA	Electronic Throttle Control (ETC) driver
TLE9102SG	New cost-efficient H-bridge driver for non-ETC use cases, such as Exhaust Gas Recirculation (EGR), turbocharger wastegate, turbocharger geometry and other DC motor driver actuators
Low-side driver	Smart low-side power switches in single- or multi-channel configuration. Applicable product families: FLEX, IPS.
TLE50xx, TLE49xx, KP2xx	Broad portfolio of pressure sensors (MAP and BAP) as well as magnetic cam- and crankshaft and position sensors
KP27x	Sensor with a digital SENT interface in development
MOSFET	New 60/100 V N-Channel MOSFET products in a compact Dual-SSO8 package
LIN transceiver	LIN (Local Interconnect Network) bus for local communication between actuators, sensors or switches and an ECU
FlexRay transceiver	FlexRay: serial, deterministic bus transceiver for real-time control applications
TLE425x, TLE1xx	Linear-voltage trackers for supplying sensors

Diesel direct injection

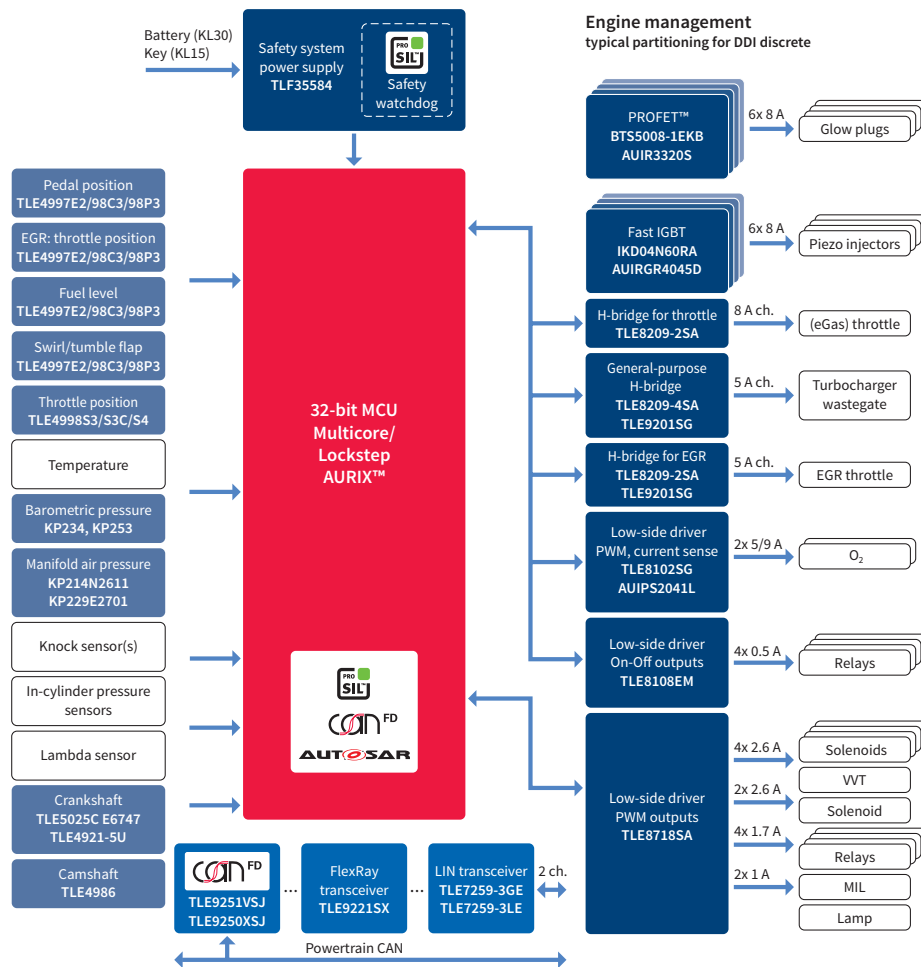

System benefits

- › Large and scalable product portfolio tailored to the performance needs of the entire diesel segment
- › Conforms with upcoming emission legislation while delivering maximum fuel efficiency and the ultimate in driving pleasure
- › Benchmark-setting real-time performance facilitates in-cylinder pressure measurement and highly efficient after-treatment (incl. hot and cold EGR, oxidation catalyst, particulate treatment and NOx treatment)
- › New sensor families provide enhanced measurement precision

Suggested products

Product name	Description
AURIX™	32-bit multicore TriCore™ microcontroller family, optimized for highly demanding powertrain applications (PRO-SIL™)
TLF35584	High-efficiency system power supply (PRO-SIL™)
Transceivers	New CAN/LIN/FlexRay transceivers
TLE8209-2SA/-4SA	Electronic Throttle Control (ETC) driver
TLE9102SG	New cost-efficient H-bridge driver for non-ETC use cases, such as Exhaust Gas Recirculation (EGR), turbocharger wastegate, turbocharger geometry and other DC motor driver actuators
Low-side driver	Smart low-side power switches in single- or multi-channel configuration. Applicable product families: FLEX, IPS.
TLE50xx, TLE49xx, KP2xx	Broad portfolio of pressure sensors (MAP and BAP) as well as magnetic cam- and crankshaft and position sensors
KP27x	Sensor with a digital SENT interface in development
TLE425x, TLS1xx	Linear-voltage trackers for supplying sensors



LIN alternator regulator

Regular diodes (3-phase example)

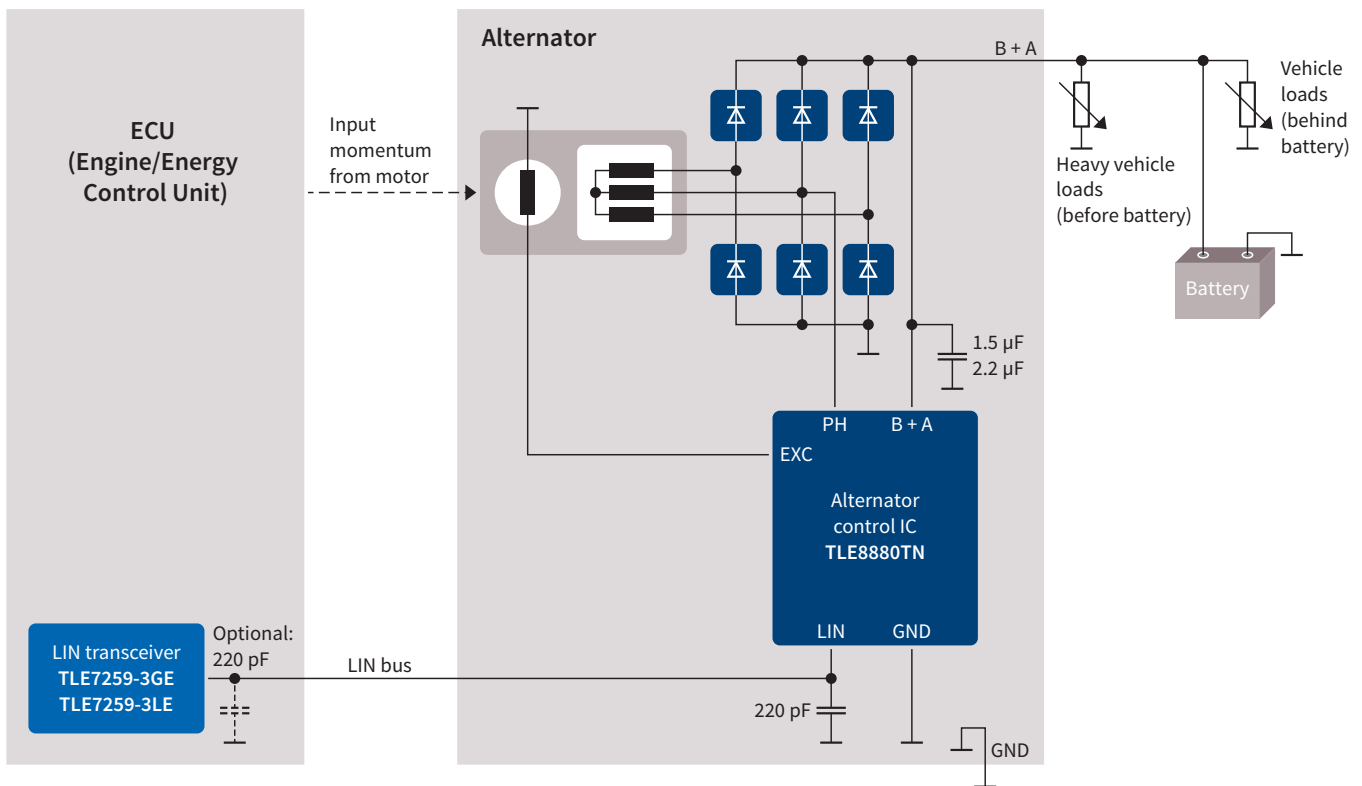

System benefits

- > Supports conventional alternator and start-stop systems
- > Fully digital PI regulation with a very fast and accurate performance
- > Compliant with VDA LIN-generator-regulator specifications
- > Supports rectification with standard P/N diodes, low-loss diodes and MOSFETs
- > EEPROM for outstanding flexibility during on-site customization of target application
- > LIN interface (LIN 2.1 on physical layer, LIN 1.3/LIN2.1 on datalink layer)
- > Very low quiescent current (less than 80 μA at 25°C), excellent EMC performance
- > High ESD resistivity of 8 kV on all lines
- > High current (12 A) and temperature (up to 175°C) capability
- > Available as bare die for mechatronic brush holder as well as in automotive industrial standard packages TO-220-5
- > Green product (RoHS-compliant) and AEC-Q100-qualified

Suggested products

Product name	Description
TLE8880/TLE8881	Monolithic full-feature regulator specifically designed for closed-loop voltage control in 12 V automotive multi-phase alternators. This regulator is able to communicate with an engine-management or energy-management ECU via a standard LIN1.3 (datalink layer) interface. By using freely adjustable parameters, the regulator is able to operate even without any communication interface.
TLE8886	Same as TLE8880/TLE8881 but, among others, ECU communication via a standard LIN2.1 (datalink layer) interface
TLE7259-3GE/-3LE	LIN transceiver with integrated wake-up and protection features

Electric water pump

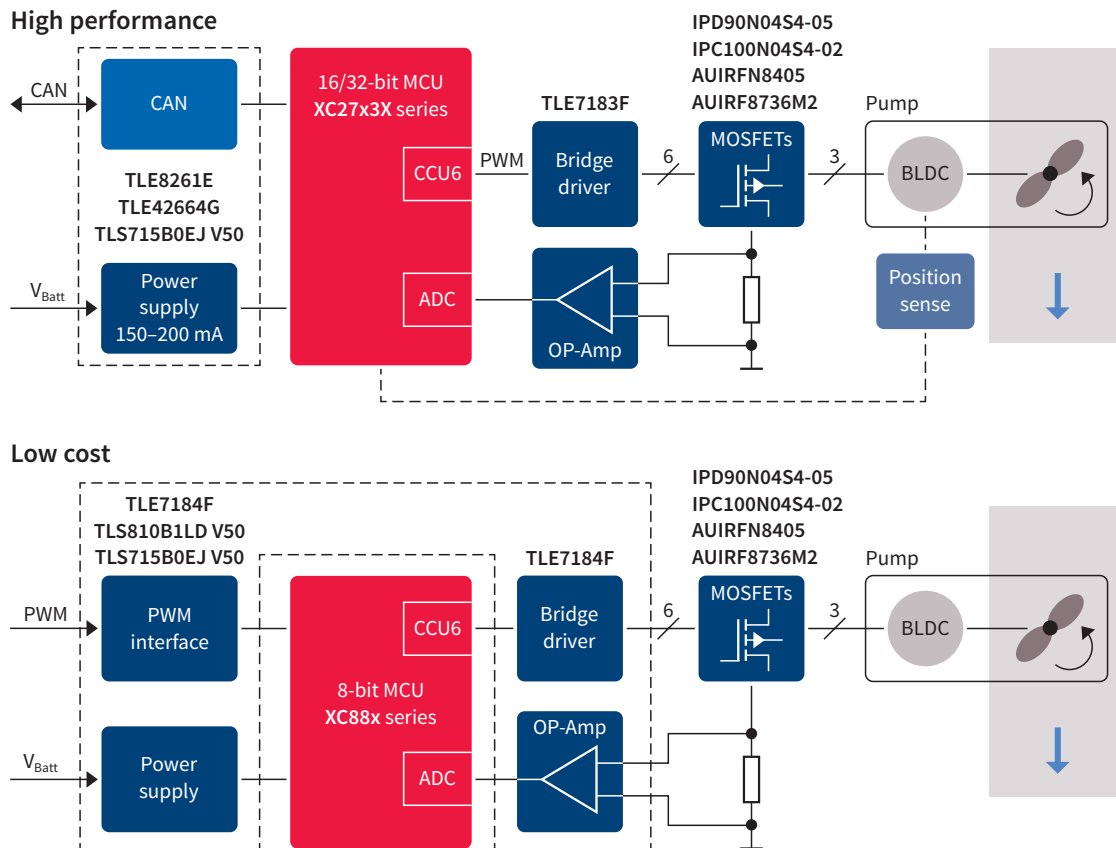

System benefits

- > Large and scalable product portfolio tailored to performance and budget requirements
- > Fuel saving of > 4 percent compared to mechanical solution
- > Improved thermal control of engine
- > Enhanced pump efficiency
- > Reduces power consumption

Suggested products

Product name	Description
XC27xx	C166-compatible 16-bit microcontroller powertrain family (up to 1 MB flash at 128 MHz performance)
XC8xx	8051-compatible automotive 8-bit microcontrollers
TLE718x	High-current 3-phase bridge driver ICs
TLE826x	Monolithic integrated System Basis Chips (SBC) in enhanced power packages
TLE42xx	Low-dropout fixed-voltage regulator
MOSFET	N-channel 40 V MOSFET, optimized for high-current motor applications
TLS810, TLS715	Linear-voltage regulators

Fuel pump

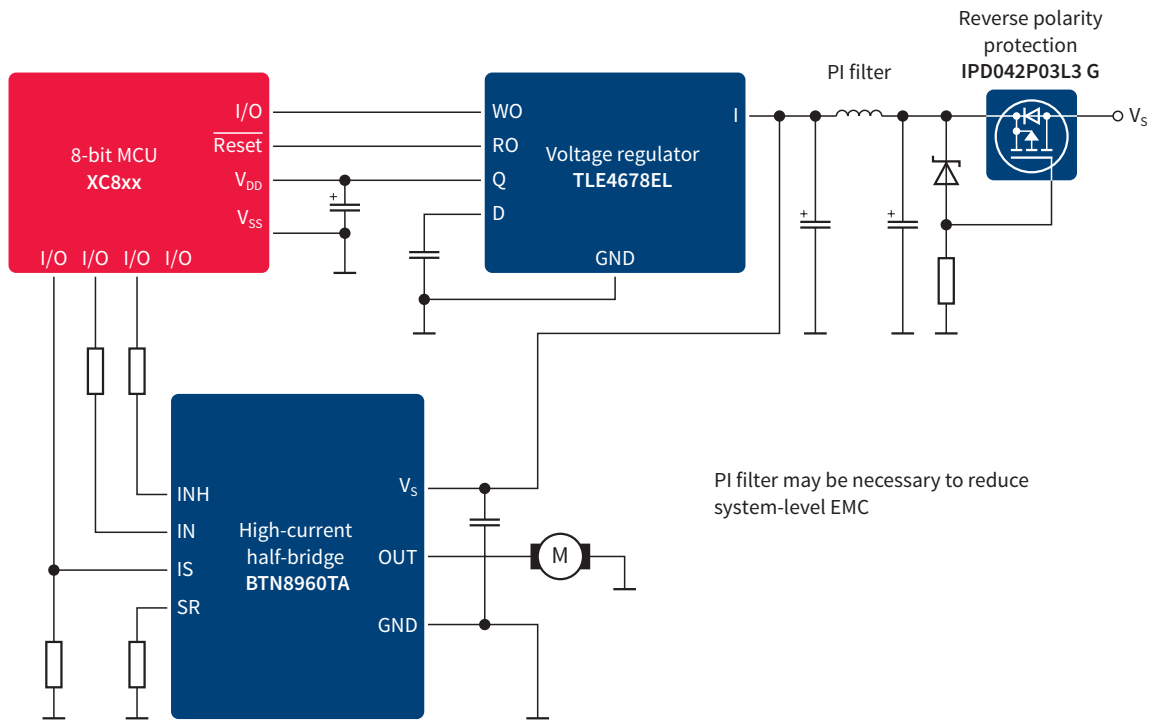

System benefits

- > Large and scalable product portfolio tailored to performance and budget requirements
- > Fuel saving of > 1 percent compared to mechanical solution
- > Lower hydrocarbon emissions
- > Increased lifetime

Suggested products

Product name	Description
XC8xx	8051-compatible automotive 8-bit microcontrollers
BTN89xx	NovalithIC™ integrates the high-current PN half-bridge family
TLE46xx	Low-dropout linear-voltage regulator with reset and watchdog

Small engine starter kit

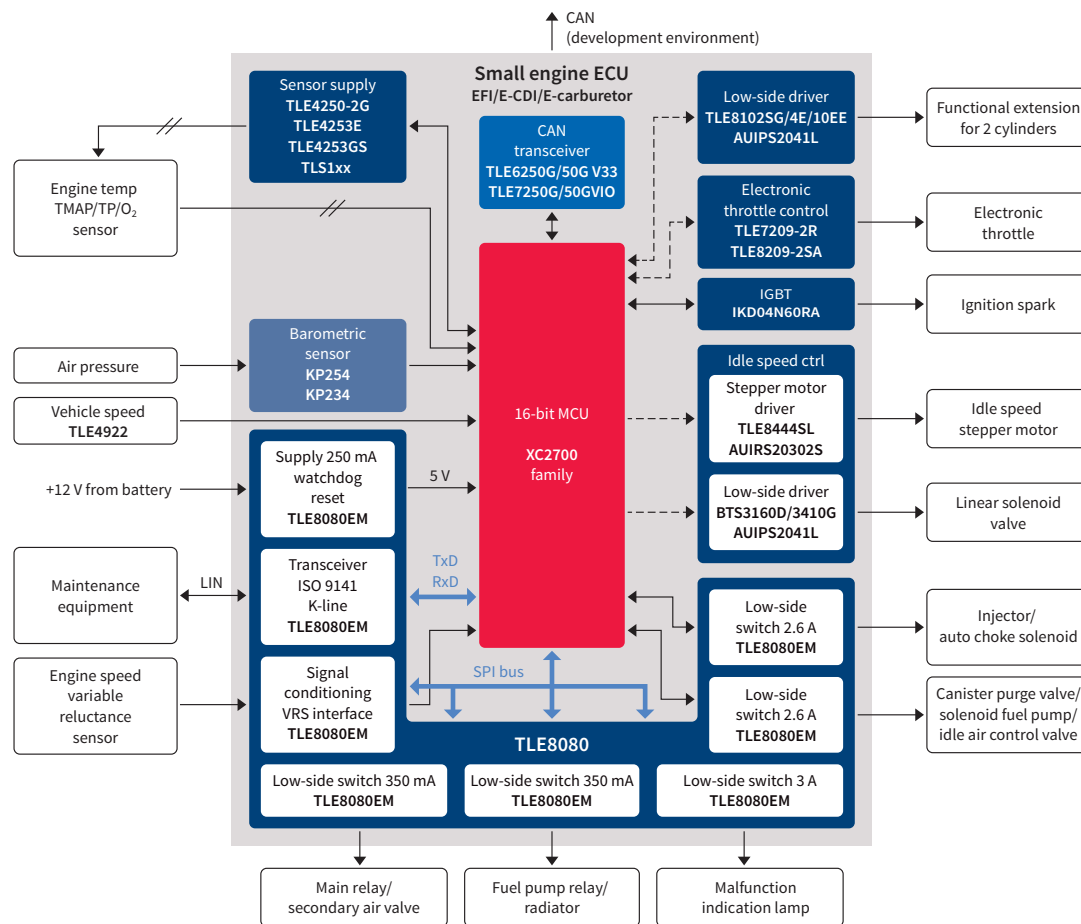

Complete Infineon reference solution including

- › Small engine control unit
- › MECTRONIK MECLAB™ configuration and calibration software for running 1-cylinder 4-stroke combustion engine systems
- › U-Connect XC2704 interface board USB-CAN
- › Miniwiggler JTAG debugging interface
- › Cable harness

Target applications

- › Electronic Fuel Injection (EFI)
- › Electronic e-carburetor
- › Enhanced capacitor discharge ignition

Features/benefits

- › Easy to use as reference board
- › Plug-and-play Electronic Control Unit (ECU)

Suggested products

Product name	Description
XC2733	C166-compatible high-performance 16-bit MCU (up to 150 KB flash at 66 MHz performance)
TLE7209/8209	Electronic throttle control driver
TLE810x/8110	Multi-channel switches
Low-side driver	Smart low-side power switches in single- or multi-channel configuration. Applicable product families: HITFET, FLEX, IPS.
TLE8444	Stepper motor driver
TLE8080EM	The power system chip for 1- and 2-cylinder small engine management
TLE42xx	Low-dropout fixed-voltage regulator
TLE425x, TLS1xx	Linear-voltage trackers for supplying sensors
KP23x/KP25x	Barometric Air Pressure sensors (BAP) with an analog or SPI/digital interface
TLE4922	New magnetic speed sensor

Small 1-cylinder combustion engine solution

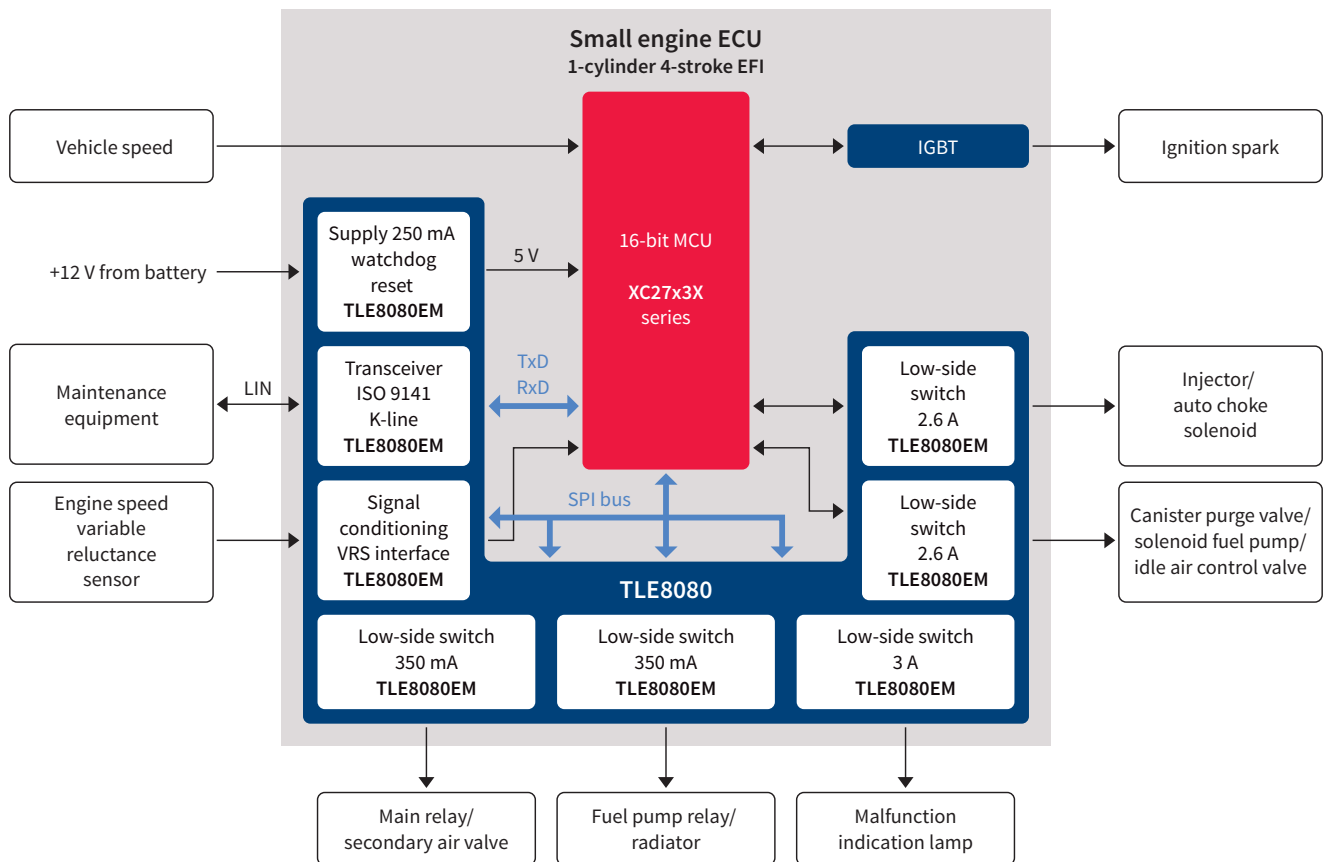

System benefits

- > Scalable chipset solutions supporting EFI, e-carburetor and CDI system approaches
- > Highest feature density in smallest package supporting smallest form factor
- > Single-device TLE8080EM solution for managing the entire electronic power interface of a 1-cylinder combustion engine
- > Scalable and easy-to-use XC2700 family supporting easy-to-implement up- and downgrade options for functional enhancement or cost optimization
- > CO₂ reduction of 17 g/km and fuel efficiency increase of 16 mpg

Suggested products

Product name	Description
XC2733	C166-compatible high-performance 16-bit MCU (up to 128 KB flash at 66 MHz performance)
TLE8080EM	The power system chip for 1- and 2-cylinder small engine management

(H)EV applications

Although electric drivetrains are already more energy efficient than combustion models, further improvements are still required. Infineon delivers various chips and modules that can play a valuable role in minimizing power losses, maximizing power savings and boosting performance. As a leading supplier of high-power IGBT modules for drive and traction applications for many decades now, Infineon supplied the IGBT modules that powered the TGV to a new world speed record in 2007, for example. Drawing on its industrial experience, Infineon has developed dedicated (H)EV power modules delivering the ultimate in power density and efficiency.

As the world leader in advanced power and automotive electronics, Infineon has the broadest product portfolio for high-efficiency electric drivetrain designs. Combining affordability with ecology, our electromobility solutions help to significantly reduce the overall system cost of powertrain and electronics, increase mileage and improve battery efficiency. Carmakers and system suppliers can rely on best-in-class semiconductor products from Infineon Technologies to drive new innovations. For instance, 75 Infineon semiconductors ensure a highly efficient electric drive in the new BMW i3, including, for example, a TriCore™ 32-bit microcontroller, IGBT power module, EiceDRIVER™ products and CoolMOS™ high-voltage MOSFETs. And this is only one example.

Suitable for all electric drivetrain architectures, Infineon's product portfolio comprises discrete components, power semiconductors, microcontrollers and sensors, as well as high-power modules. Thanks to our system expertise, we are able to provide complete chipsets offering optimized performance while reducing overall system costs.

Infineon's semiconductor solutions for (H)EV are testament to the company's ongoing commitment to deliver the exceptional quality and reliability that the world's leading car and automotive system manufacturers expect.

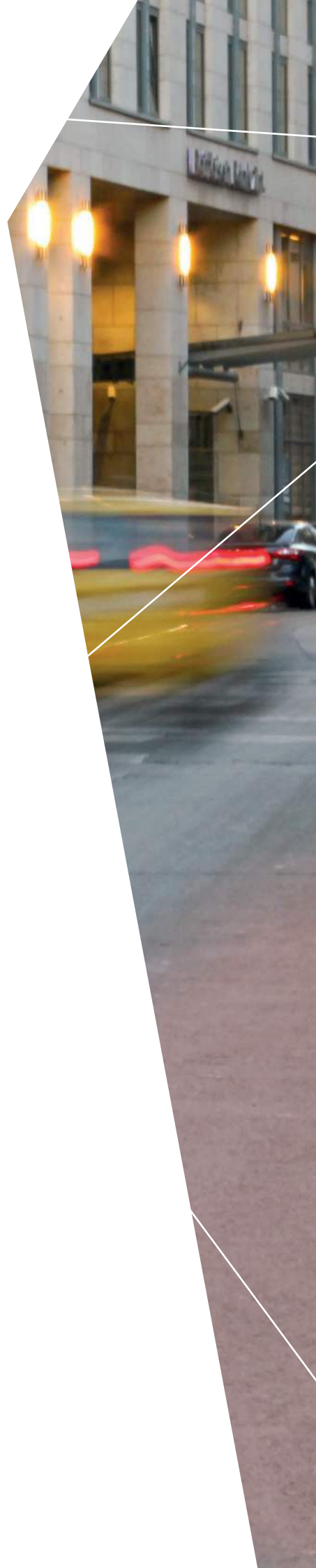



(H)EV – main inverter

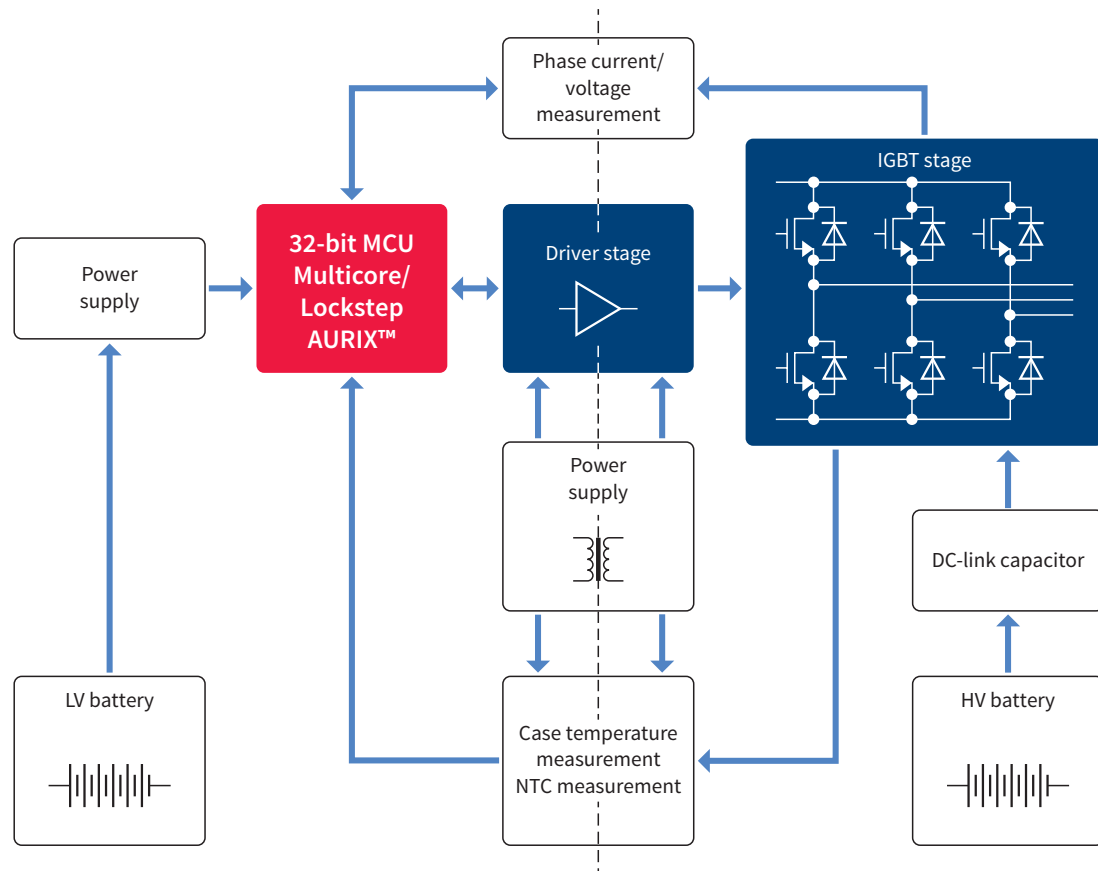

System benefits

- › Fully automotive-qualified product portfolio supporting a wide range of motors, generators and power classes
- › Highly efficient 3-phase driver thanks to very low conducting losses even at high switching frequencies
- › Isolation integrated in gate driver
- › Wide range of 32-bit microcontroller solutions dedicated to (H)EV applications with a highly cost-effective resolver interface
- › Evaluation kit available to reduce system development time

Suggested products

Product name	Description
AURIX™	High-performance 32-bit multicore lockstep microcontrollers
1ED020I12FA2/2ED020I12FA	Automotive EiceDRIVER™, single/dual-channel isolated IGBT driver for 650 V/1200 V IGBTs
1EDI2001AS/1EBN1001AE	Next-generation EiceDRIVER™ supporting cost-effective implementation of ASIL-C/D systems
HybridPACK™ Drive	New – IGBT power module with 820 A/750 V with power ratings above 150 kW – coming soon
HybridPACK™	IGBT power modules dedicated to automotive applications with power ratings up to 200 kW
HybridPACK™ 1 DC6	IGBT power module with 400 A/705 V for power ratings up to 100 kW
1EDI2010AS/1EBN1002AE	Next-generation EiceDRIVER™ supporting cost-effective implementation of ASIL-C/D systems (in development)

(H)EV – auxiliary inverter

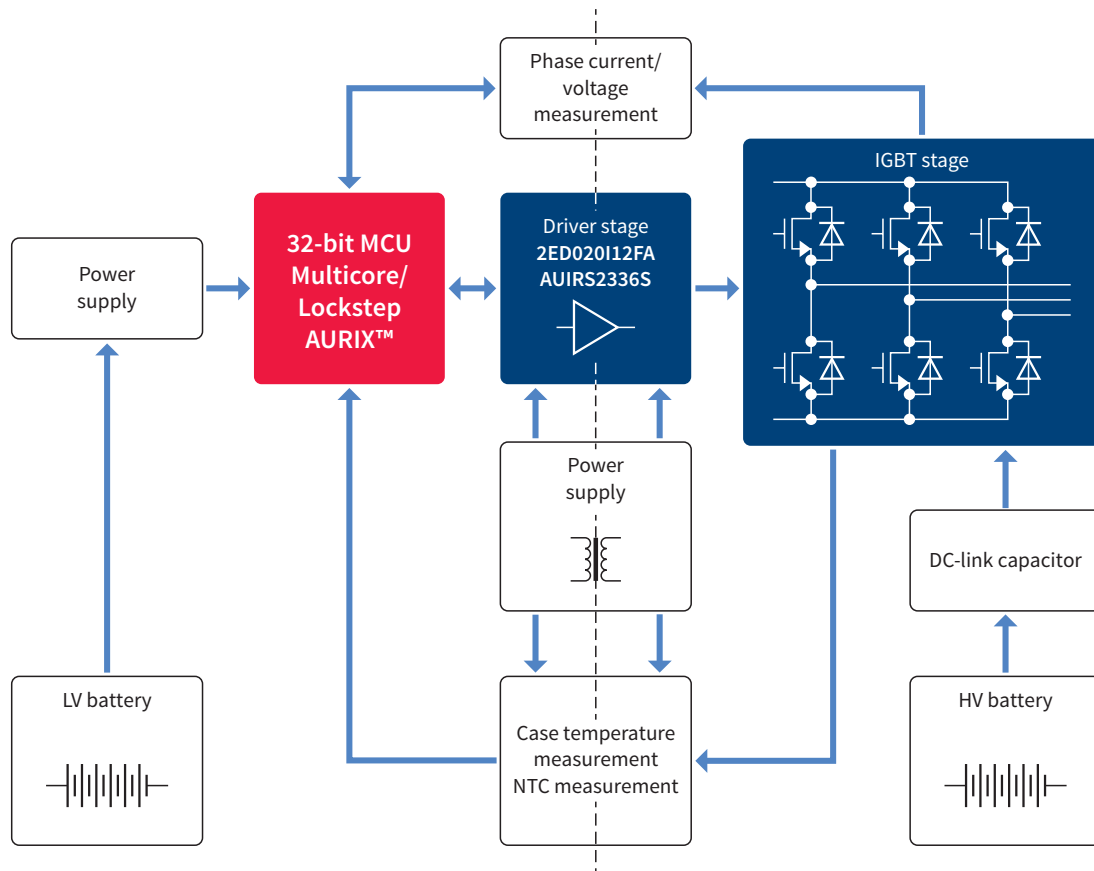

System benefits

- › Fully automotive-qualified product portfolio including both power module and discrete solutions
- › Highly efficient 3-phase driver thanks to very low conducting losses even at high switching frequencies
- › Isolation integrated in gate driver
- › Broad 32-bit microcontroller solutions dedicated to (H)EV applications
- › Evaluation kit available to reduce system development time

Suggested products

Product name	Description
AURIX™	New 32-bit TriCore™ lockstep microcontroller
1ED020I12FA2	Automotive EiceDRIVER™, single-channel isolated IGBT driver for 650 V/1200 V IGBTs
2ED020I12FA	Automotive EiceDRIVER™, dual-channel isolated IGBT driver for 50 V/1200 V IGBTs
IKxxN60TA	IGBT discretes from 20 A to 75 A, 600 V with soft, fast recovery anti-parallel EmCon HE diode
Automotive Easy	IGBT power modules dedicated to automotive applications with power ratings up to 10 kW
AUIRS2336S	Three-phase bridge driver for 600 V IGBT

(H)EV – auxiliary HV/LV DC-DC

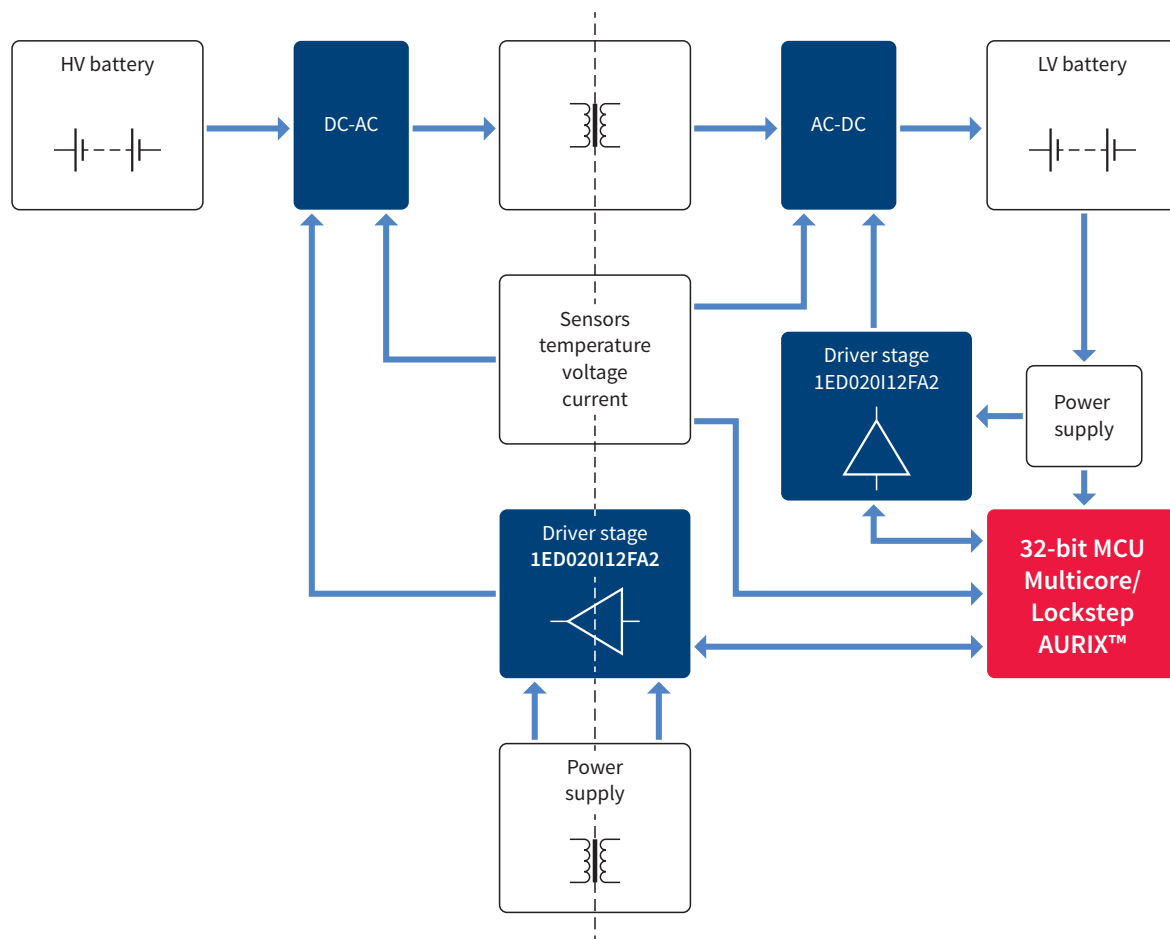
**System benefits**

- › Fully automotive-qualified product portfolio including both power module and discrete solutions
- › Supports a wide range of highly efficient conversion topologies (including bidirectional)
- › Compact design with the highest power density
- › Very low switching losses at high switching frequencies
- › Isolation integrated in gate driver
- › High-performance 32-bit microcontroller solutions
- › Evaluation kit available to reduce system development time

Suggested products

Product name	Description
AURIX™	New 32-bit TriCore™ lockstep microcontroller
1ED020I12FA2	Automotive EiceDRIVER™, single-channel isolated IGBT driver for 650 V/1200 V IGBTs
2ED020I12FA	Automotive EiceDRIVER™, dual-channel isolated IGBT driver for 650 V/1200 V IGBTs
IPx65RxxxCFDA	650 V CoolMOS™ discrete high-voltage MOSFETs with a fast body diode
Automotive Easy	IGBT power modules dedicated to automotive HV/LV DC-DC converters with switching frequencies up to 100 kHz

(H)EV – AC-DC (battery charger)

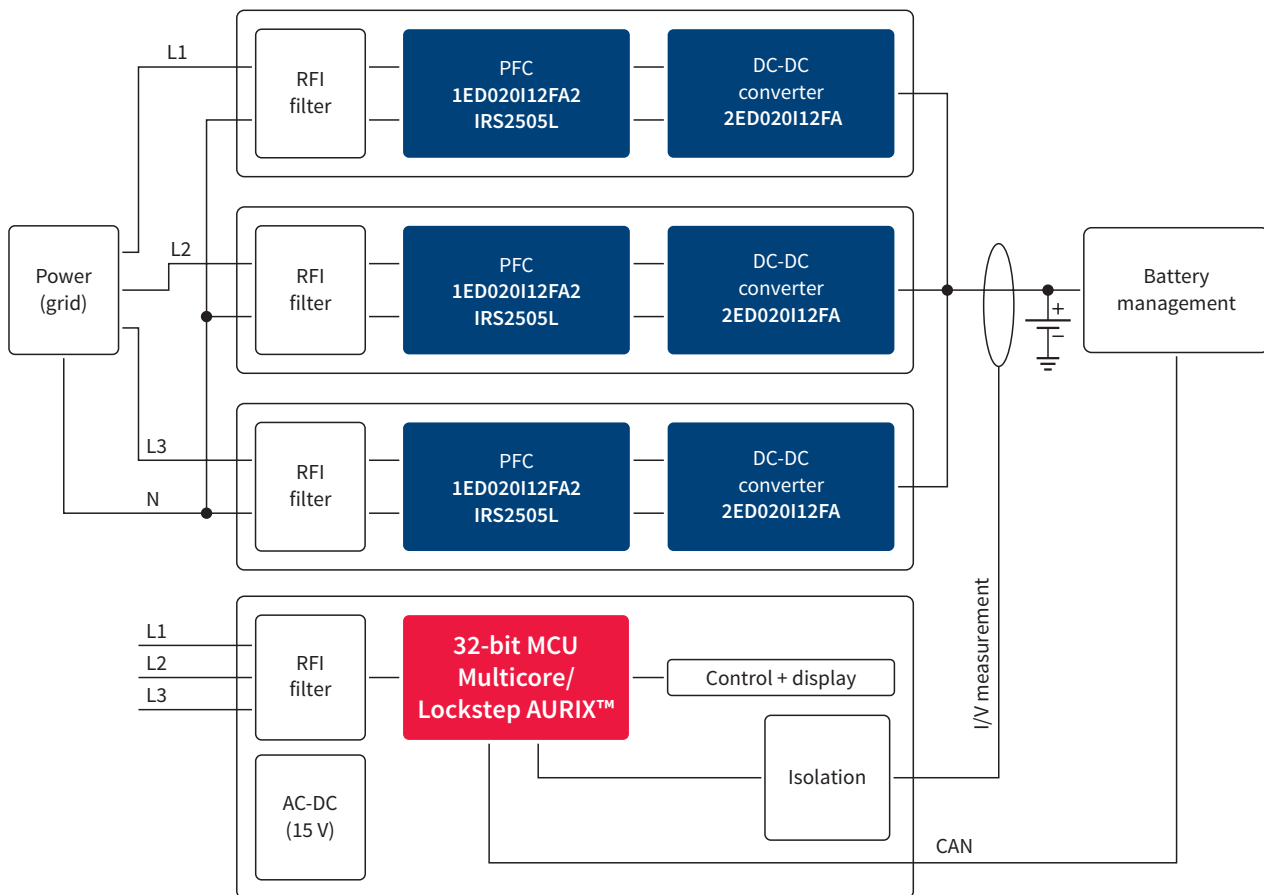
**System benefits**

- > Suitable for plug-in hybrid and EV
- > Integrated Power Factor Correction (PFC)
- > Galvanic isolation
- > Wide range of input and output voltages
- > Adjustable current limits
- > Automotive standard communication (CAN)
- > Modular concept enables 1 to 3-phase AC power supply

Suggested products

Product name	Description
AURIX™	New 32-bit TriCore™ lockstep microcontroller
1ED020I12FA2	Automotive EiceDRIVER™, single-channel isolated IGBT driver for 650 V/1200 V IGBTs
2ED020I12FA	Automotive EiceDRIVER™, dual-channel isolated IGBT driver for 650 V/1200 V IGBTs
CoolMOS™ (IPx65RxxxCFDA)	High-voltage automotive MOSFETs for low-power charging solutions (overnight)
Automotive Easy	Flexible power module solution for low-power charging solutions



Trusted driving with secured connectivity

As the global market leader in security microcontrollers for 15 consecutive years and with more than 40 years of experience in the automotive sector, Infineon offers a broad portfolio of cost-effective automotive security solutions. The product range includes hardware components, such as 32-bit microcontrollers with embedded hardware security modules, SIM cards, and secure elements as well as related software packages. This allows the security level – and consequently the associated cost – to be precisely custom-

ized to suit the protection needs of a particular application. Customers benefit from decades of experience in the analysis of threat and attack scenarios by virtue of security certifications, for instance the ISO/IEC 15408 (Common Criteria), and the extensive portfolio of hard- and software patents. Here, Infineon consistently relies on proven industry standards, such as AES-128, ECC-256, SHE, EVITA HSM and TPM, to reduce the integration outlay as well as the risk associated with OEMs and their tier suppliers.

Discover what's possible with Infineon's solutions in the use cases below.



Immobilizer

Authentication (i.e. proof of identity) is an integral part of automotive security systems. The best-known application is the electronic immobilizer as a central component of theft protection.



Vehicle-to-x (connected car)

Vehicle-to-Vehicle communication (V2V or C2C) and Vehicle-to-Infrastructure communication (V2I or C2I) are expected to further reduce road fatalities, improve road safety and increase traffic efficiency in the future. Furthermore, this technology could also be utilized to improve existing toll systems.



Secure onboard communication

Security solutions for onboard communication need to be safe and compliant with hard, real-time constraints and legacy bus standards, with minimum data overhead and costs.



Software update over the air (SOTA)

Updating software over the air (internet connection) requires a complex security system



Tuning protection

Chip tuning allows for increased performance of the internal combustion engine, improves acceleration and increases top speed. However, the negative consequences are often overlooked. These include the possible failure of safety inspections and loss of insurance coverage as well as additional risks to drivers, such as those associated with excessive stress on vehicle components.

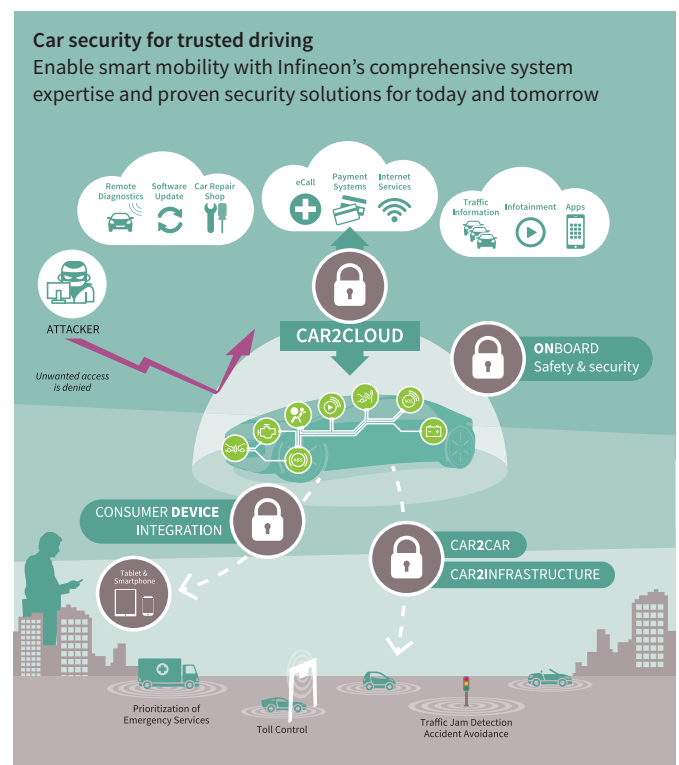

Telematics control unit

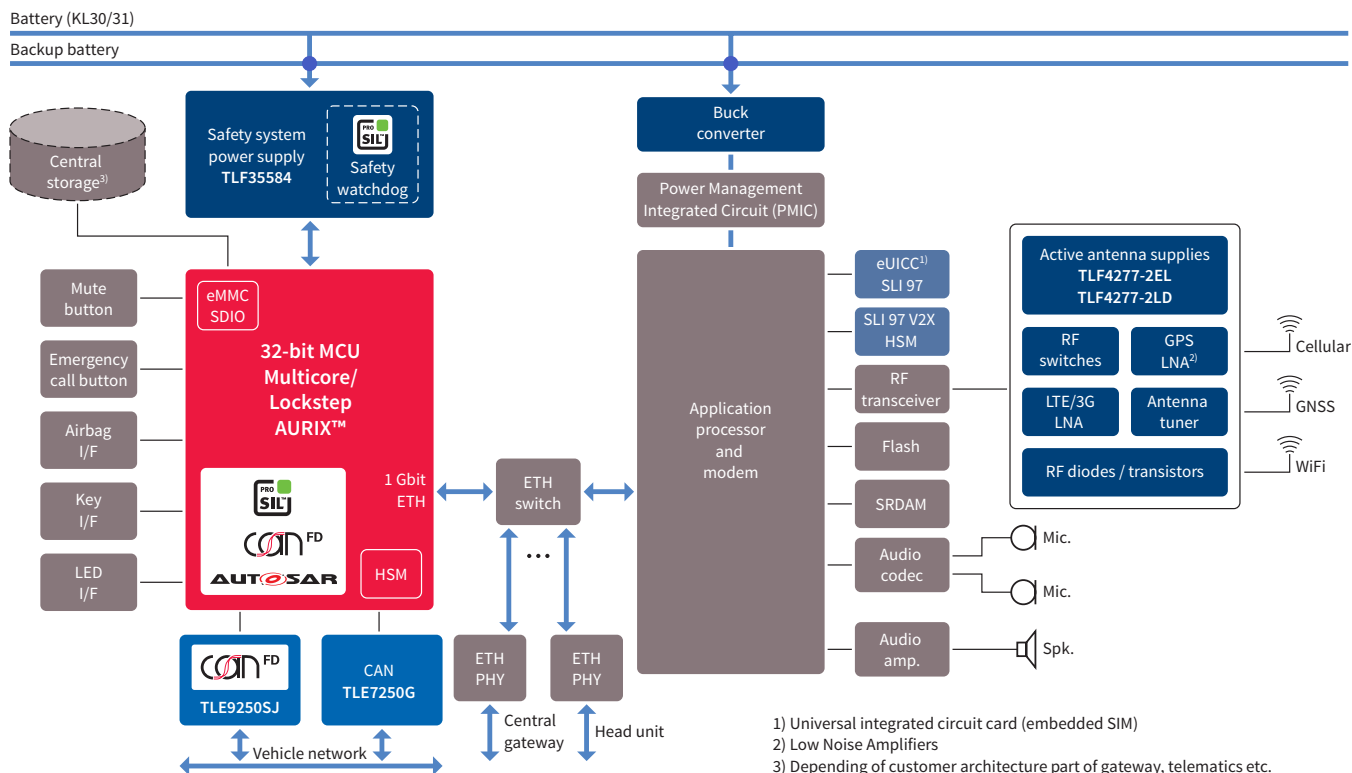

System benefits

- > Scalable high-performance AURIX™ family from single to multicore (PRO-SIL™)
- > Secure external interfaces with trusted security implemented via on-chip HSM (Hardware Security Module)
- > Dedicated microcontroller HW support for CAN, CAN FD and Ethernet
- > Network transceiver supporting CAN and CAN FD
- > Optimized tailored safety system power supply
- > Encryption support for central car storage

Interfaces

- > Connectivity
 - Ethernet up to 1 GB
 - eMMC/SDIO
 - CAN FD
- > Safety/security concept
 - Different security solutions according to custom requirements
 - ISO 26262 compliance
 - Hardware security on different levels
- > Power consumption
 - On-chip SC DC-DC high-efficiency power supply
 - Stand-by control unit for lowest quiescent current
- > System BOM view
 - RF components for frontend optimizations

Suggested products

Product name	Description
AURIX™	High-performance 32-bit multicore microcontroller family (PRO-SIL™)
TLF35584	System power supply with integrated watchdog (PRO-SIL™)
TLE9250SJ	CAN FD transceivers
TLE7250G	CAN transceivers
SLI 97	Embedded SIM – Universal Integrated Circuit Card (eUICC) for automotive communication
SLI 97 V2X	Security controllers for automotive communication (V2V, V2I, V2X)
TLF4277-2	Active antenna supply with analysis functionality

Infineon PRO-SIL™



The functional complexity and levels of integration of real-time, safety-critical applications continue to increase. Safety Standards such as IEC 61508 and ISO 26262 mandate more robust products and functional safety concepts in automotive and industrial applications.

Infineon's PRO-SIL™ trademark designates Infineon products which contain SIL-supporting (Safety Integrity Level) features. The purpose of SIL-supporting features involves assisting the overall system design in attaining the desired SIL (according to IEC 61508) or A-SIL (according to ISO 26262) level for safety systems with high efficiency. Products with the PRO-SIL™ label will help you to select Infineon products



PRO-SIL™ highlights

- › Broad hardware portfolio including sensors and micro-controllers, along with analog and power management ICs that provide SIL-supporting features
- › An independent functional safety management organization supports the ISO 26262 safety lifecycle
- › Safety documentation, such as a safety manual and safety analysis summary report, can be made available for dedicated PRO-SIL™ products (NDA may be required)
- › Infineon offers expert system integrator support for achieving the required ASIL on system level
- › Infineon's PRO-SIL™ logo will guide you to our products (HW, SW, safety documentation) with SIL-supporting features. Infineon's activities result in a simplified integration in safety-related applications.



Infineon's next level of Zero Defect program

On the way to Zero Defect products and services

The most valuable aspect of cars is the people they carry. Therefore, safety should never be compromised. This is the most important consideration for everybody involved in making automobiles – from the smallest suppliers to the manufacturers themselves. As car components become ever more complex, and as the number of control units in vehicles increases, the likelihood of a product failure becomes bigger. Quality performance is a key differentiator for automotive market success. Our target of Zero Defects means:

- › No quality events and no deviations
- › Defect-free product launches
- › All processes are under control
- › The highest quality image in the market and more business due to satisfied customers
- › Our customers enjoy a faster time-to-market

No compromise when it comes to quality

Infineon established the most comprehensive quality program called “AUTOMOTIVE EXCELLENCE” in the semiconductor industry in 2003. The continuation of the successful “Automotive Excellence” program is “NEXT LEVEL of ZERO DEFECT” which started in 2011. The program is founded on four pillars: people, products, processes and production. Thanks to our “no compromise” policy in all four pillars, our program really works. Our employees truly live the credo of Zero Defect, considering the highest quality requirements and understanding the importance of prevention. They are trained to deeply understand the tools and methods used to avoid deviations and to solve problems by addressing both technical and systemic root causes.

On the way to Zero Defect products

On the way to Zero Defect products, some examples:

- › The “Green Line” project focuses on highest stability in assembly fabs
- › Zero Defect Culture initiatives intensify the Zero Defect mindset of both staff and management
- › Our Quality Firewall project “ensures highest outgoing product quality by intelligent outlier screening”
- › Extend “Next level of Zero Defect” into supplier base

“Next level of Zero Defect” is your competitive advantage

Many of our partners have expressed their satisfaction with the quality of our products and the way we execute “Next level of Zero Defect”.

- › “Honor Quality Award Toyota Hirose” received in 2010 for Zero Defect quality for the last four years. Infineon is the first non-Japanese company to receive this honor in this highest level category.
- › Quality Awards from Toyota’s Hirose plant in 2004, 2006, 2007, 2008, 2009, 2010, 2011 and 2015
- › “Supplier Performance Award” for the year 2008 and “Automotive Supplier of the Year 2009, 2010 and 2011” from Continental
- › “Technical Development Award 2011” from Denso for quality, pricing, technical development and global collaboration. Infineon is the first non-Japanese component supplier to receive this award.
- › In 2015 Delphi Supplier Quality Award

Where to buy

Infiniteon distribution partners and sales offices:

www.infineon.com/WhereToBuy

Service hotline

Infiniteon offers its toll-free 0800/4001 service hotline as one central number, available 24/7 in English, Mandarin and German.

- > Germany 0800 951 951 951 (German/English)
- > China, mainland 4001 200 951 (Mandarin/English)
- > India 000 800 4402 951 (English)
- > USA 1-866 951 9519 (English/German)
- > Other countries 00* 800 951 951 951 (English/German)
- > Direct access +49 89 234-0 (interconnection fee, German/English)

* Please note: Some countries may require you to dial a code other than "00" to access this international number.
Please visit www.infineon.com/service for your country!



Mobile product catalog

Mobile app for iOS and Android.

www.infineon.com

Published by
Infineon Technologies AG
81726 Munich, Germany

© 2016 Infineon Technologies AG.
All rights reserved.

Order number: B124-I0010-V2-7600-EU-EC-P
Date: 12 / 2016

Please note!

THIS DOCUMENT IS FOR INFORMATION PURPOSES ONLY AND ANY INFORMATION GIVEN HEREIN SHALL IN NO EVENT BE REGARDED AS A WARRANTY, GUARANTEE OR DESCRIPTION OF ANY FUNCTIONALITY, CONDITIONS AND/OR QUALITY OF OUR PRODUCTS OR ANY SUITABILITY FOR A PARTICULAR PURPOSE. WITH REGARD TO THE TECHNICAL SPECIFICATIONS OF OUR PRODUCTS, WE KINDLY ASK YOU TO REFER TO THE RELEVANT PRODUCT DATA SHEETS PROVIDED BY US. OUR CUSTOMERS AND THEIR TECHNICAL DEPARTMENTS ARE REQUIRED TO EVALUATE THE SUITABILITY OF OUR PRODUCTS FOR THE INTENDED APPLICATION.

WE RESERVE THE RIGHT TO CHANGE THIS DOCUMENT AND/OR THE INFORMATION GIVEN HEREIN AT ANY TIME.

Additional information

For further information on technologies, our products, the application of our products, delivery terms and conditions and/or prices, please contact your nearest Infineon Technologies office (www.infineon.com).

Warnings

Due to technical requirements, our products may contain dangerous substances. For information on the types in question, please contact your nearest Infineon Technologies office.

Except as otherwise explicitly approved by us in a written document signed by authorized representatives of Infineon Technologies, our products may not be used in any life-endangering applications, including but not limited to medical, nuclear, military, life-critical or any other applications where a failure of the product or any consequences of the use thereof can result in personal injury.