

DESCRIPTION: M12 FEMALE - PANEL MOUNT (REAR) - 8 POS.

NOTE:

MATERIAL
 HOUSING: PBT UL94V-0, BLACK
 CONTACT: BRASS
 NUT: BRASS
 SHELL: BRASS
 O-RING: EPDM, BLACK
 FINISH
 CONTACT: GOLD PLATED
 OVER 50µ" NICKEL
 NICKEL PLATED
 NICKEL PLATED
 ELECTRICAL
 RATED CURRENT: 2A
 RATED VOLTAGE: 30V
 INSULATION RESISTANCE: 100 MOhms MIN.
 CONTACT RESISTANCE: 10 mOhms MAX.
 WATER PROOF: IP67
 ENVIRONMENT
 OPERATION TEMPERATURE: -40°C TO +85°C

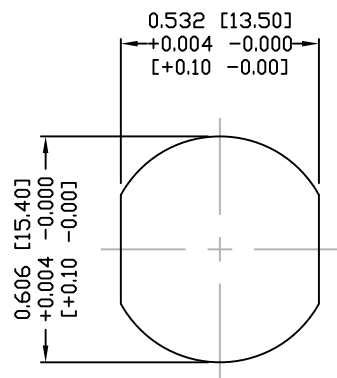

PANEL CUTOUT

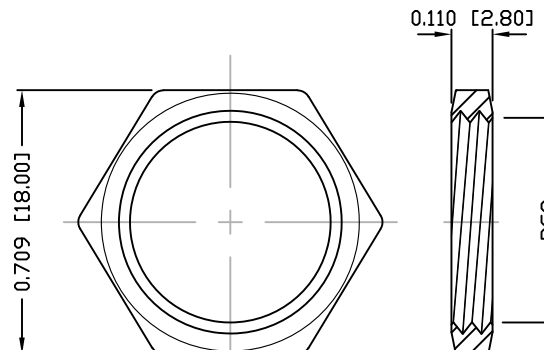

NUT

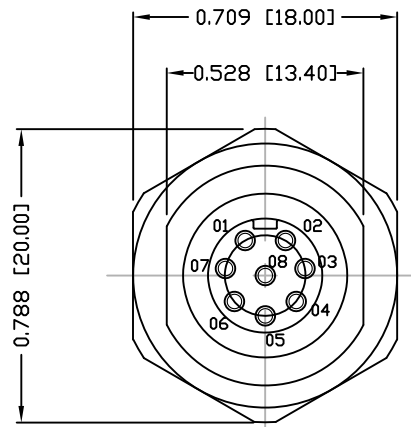
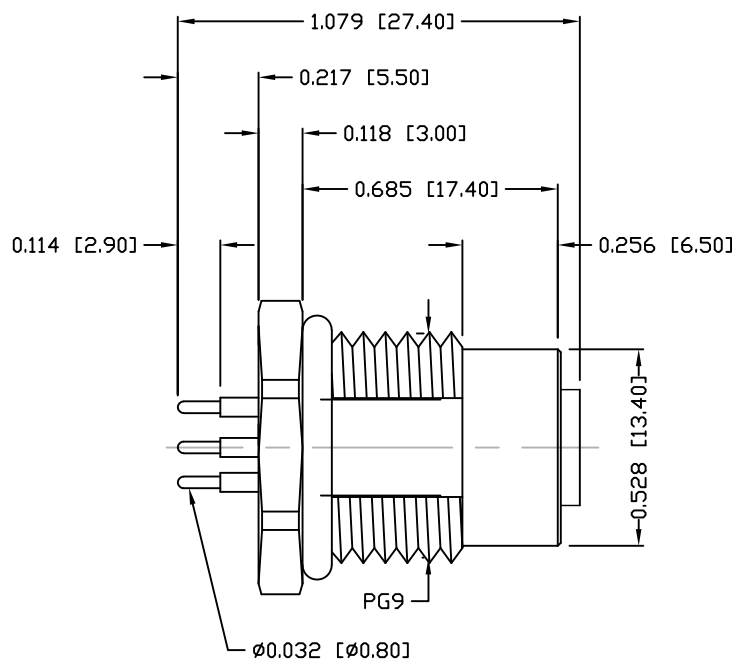

860-008-213R00Y

3 = BRASS/NICKEL SHELL & NUT
 S = STAINLESS STEEL SHELL & NUT

1 = GOLD FLASH
 4 = 10µ" GOLD

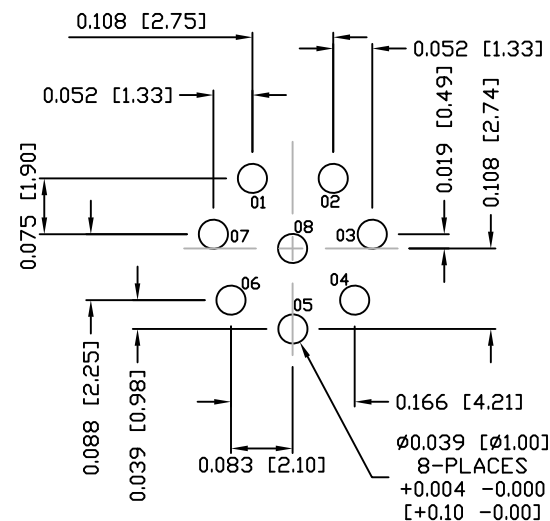

PCB LAYOUT

DO NOT SCALE FROM DRAWING

RoHS COMPLIANT

UNITS = INCHES [MM]



THESE DRAWINGS AND SPECIFICATIONS ARE THE PROPERTY OF NorComp AND SHALL NOT BE REPRODUCED, COPIED OR USED AS THE BASIS FOR THE MANUFACTURE OR SALE OF APPARATUS WITHOUT WRITTEN PERMISSION.

DRAWN:

M. SIGMON

DATE:

03-07-16

NorComp

SCALE:

NTS

SHEET OF

1 1

REV

3

DWG NO.

860-008-213R00Y