

# NX3DV221

High-speed USB 2.0 switch with enable

Rev. 4 — 19 June 2013

Product data sheet

## 1. General description

---

The NX3DV221 is a high-bandwidth switch designed for the switching of high-speed USB 2.0 signals in handset and consumer applications. These applications could be cell phones, digital cameras, and notebooks with hubs or controllers with limited USB I/Os. The wide bandwidth (1 GHz) of this switch allows signal to pass with minimum edge and phase distortion. The device multiplexes differential outputs from a USB host device to one of two corresponding outputs. The switch is bidirectional and offers little or no attenuation of the high-speed signals at the outputs. It is designed for low bit-to-bit skew and high channel-to-channel noise isolation, and is compatible with various standards, such as high-speed USB 2.0 (480 Mbps).

## 2. Features and benefits

---

- Wide supply voltage range from 2.3 V to 3.6 V
- Switch voltage accepts signals up to 5.5 V
- 1.8 V control logic at  $V_{CC} = 3.6$  V
- Low-power mode when  $\overline{OE}$  is HIGH (2  $\mu$ A maximum)
- 6  $\Omega$  (maximum) ON resistance
- 0.1  $\Omega$  (typical) ON resistance mismatch between channels
- 6 pF (typical) ON-state capacitance
- High bandwidth (1.0 GHz typical)
- Latch-up performance exceeds 100 mA per JESD 78B Class II Level A
- ESD protection:
  - ◆ HBM JESD22-A114F Class 3A exceeds 8000 V
  - ◆ CDM JESD22-C101E exceeds 1000 V
  - ◆ HBM exceeds 12000 V for I/O to GND protection
- Specified from  $-40$  °C to  $+85$  °C

## 3. Applications

---

- Routes signals for USB 1.0, 1.1 and 2.0



## 4. Ordering information

**Table 1. Ordering information**

Type number	Package			Version
	Temperature range	Name	Description	
NX3DV221GM	-40 °C to +85 °C	XQFN10	plastic extremely thin quad flat package; no leads; 10 terminals; body 2 × 1.55 × 0.5 mm	SOT1049-3
NX3DV221TK	-40 °C to +85 °C	HVSON10	plastic thermal enhanced very thin small outline package; no leads; 10 terminals; 3 × 3 × 0.85 mm	SOT650-2

## 5. Marking

**Table 2. Marking**

Type number	Marking code <sup>[1]</sup>
NX3DV221GM	x21
NX3DV221TK	x21

[1] The pin 1 indicator is located on the lower left corner of the device, below the marking code.

## 6. Functional diagram

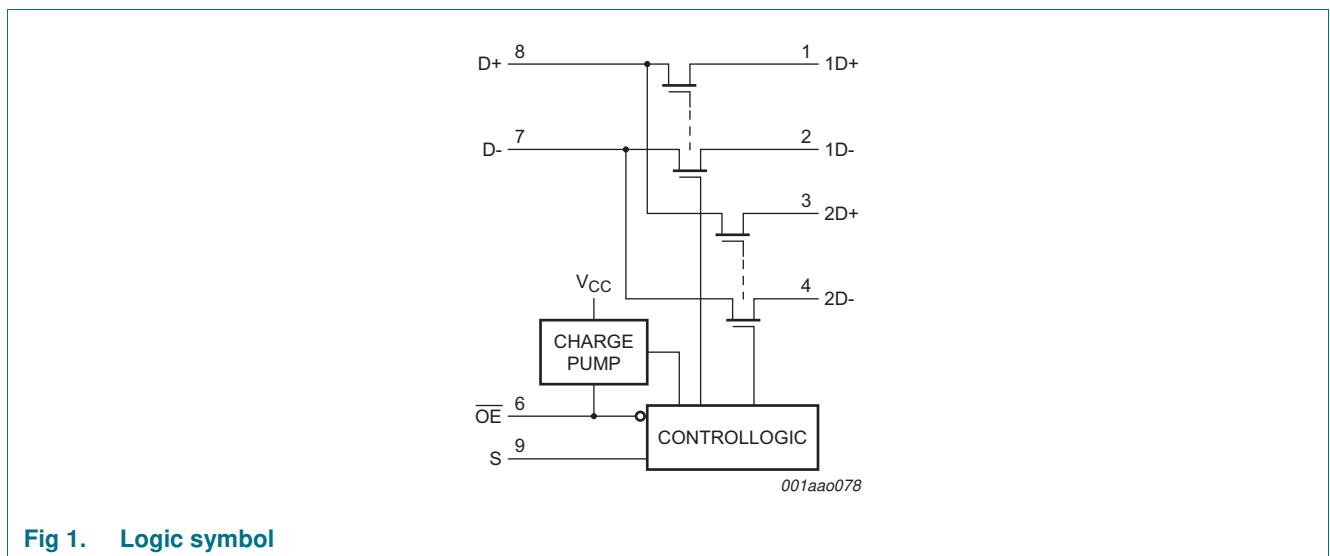

## 7. Pinning information

### 7.1 Pinning

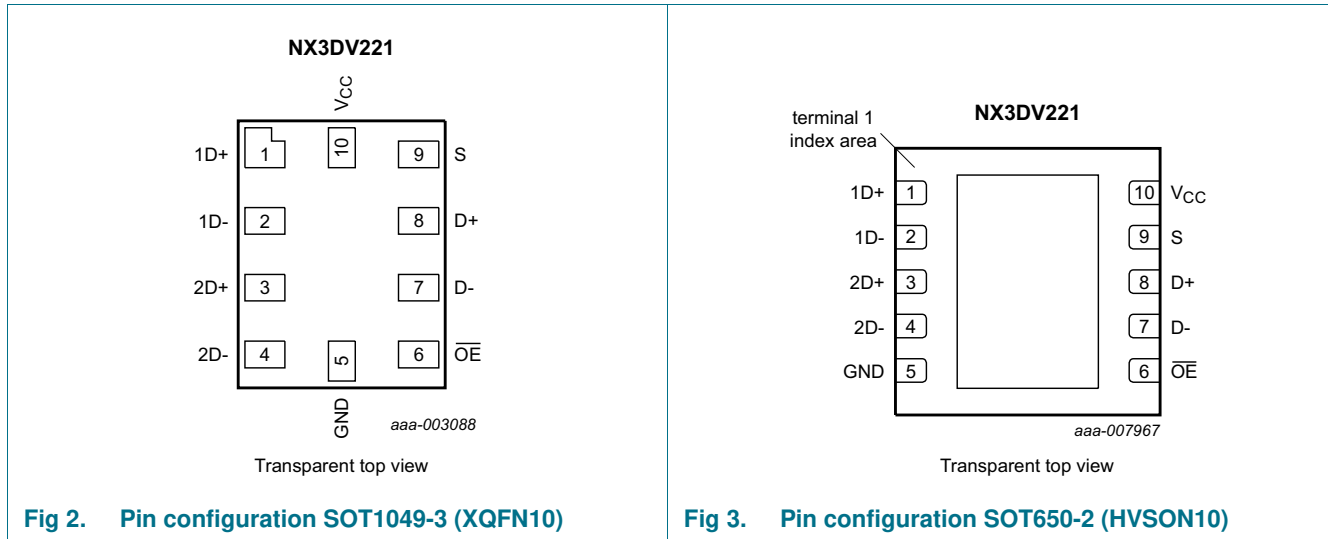

**Fig 2. Pin configuration SOT1049-3 (XQFN10)**

**Fig 3. Pin configuration SOT650-2 (HVSON10)**

### 7.2 Pin description

**Table 3. Pin description**

Symbol	Pin	Description
1D+	1	independent input or output
1D-	2	independent input or output
2D+	3	independent input or output
2D-	4	independent input or output
GND	5	ground (0 V)
$\overline{\text{OE}}$	6	output enable input (active LOW)
D-	7	common input or output
D+	8	common input or output
S	9	select input
V <sub>CC</sub>	10	supply voltage

## 8. Functional description

**Table 4. Function table<sup>[1]</sup>**

Input	$\overline{\text{OE}}$	Channel
L	L	D+ = 1D+; D- = 1D-
H	L	D+ = 2D+; D- = 2D-
X	H	switches off

[1] H = HIGH voltage level; L = LOW voltage level; X = don't care.

## 9. Limiting values

**Table 5. Limiting values**

In accordance with the Absolute Maximum Rating System (IEC 60134). Voltages are referenced to GND (ground = 0 V).

Symbol	Parameter	Conditions	Min	Max	Unit
V <sub>CC</sub>	supply voltage		-0.5	+4.6	V
V <sub>I</sub>	input voltage	S, $\overline{\text{OE}}$ input	[1] -0.5	+7.0	V
V <sub>SW</sub>	switch voltage		[2] -0.5	+7.0	V
I <sub>IK</sub>	input clamping current	V <sub>I</sub> < -0.5 V	-50	-	mA
I <sub>SK</sub>	switch clamping current	V <sub>I</sub> < -0.5 V	-50	-	mA
I <sub>SW</sub>	switch current		-	±120	mA
I <sub>CC</sub>	supply current		-	+100	mA
I <sub>GND</sub>	ground current		-100	-	mA
T <sub>stg</sub>	storage temperature		-65	+150	°C
P <sub>tot</sub>	total power dissipation	T <sub>amb</sub> = -40 °C to +125 °C	-	250	mW

[1] The minimum input voltage rating may be exceeded if the input current rating is observed.

[2] The minimum and maximum switch voltage ratings may be exceeded if the switch clamping current rating is observed.

## 10. Recommended operating conditions

**Table 6. Recommended operating conditions**

Symbol	Parameter	Conditions	Min	Max	Unit
V <sub>CC</sub>	supply voltage		2.3	3.6	V
V <sub>I</sub>	input voltage	S, $\overline{\text{OE}}$ input	0	V <sub>CC</sub>	V
V <sub>SW</sub>	switch voltage		0	5.5	V
T <sub>amb</sub>	ambient temperature		-40	+85	°C

## 11. Static characteristics

**Table 7. Static characteristics**

At recommended operating conditions; voltages are referenced to GND (ground 0 V).

Symbol	Parameter	Conditions	T <sub>amb</sub> = 25 °C			T <sub>amb</sub> = -40 °C to +85 °C		Unit
			Min	Typ	Max	Min	Max	
V <sub>IH</sub>	HIGH-level input voltage	V <sub>CC</sub> = 2.3 V to 2.7 V	-	-	-	0.46V <sub>CC</sub>	-	V
		V <sub>CC</sub> = 2.7 V to 3.6 V	-	-	-	0.46V <sub>CC</sub>	-	V
V <sub>IL</sub>	LOW-level input voltage	V <sub>CC</sub> = 2.3 V to 2.7 V	-	-	-	-	0.25V <sub>CC</sub>	V
		V <sub>CC</sub> = 2.7 V to 3.6 V	-	-	-	-	0.25V <sub>CC</sub>	V
V <sub>IK</sub>	input clamping voltage	V <sub>CC</sub> = 2.7 V, 3.6 V; I <sub>I</sub> = -18 mA	-	-	-	-	-1.8	V
I <sub>I</sub>	input leakage current	S, $\overline{\text{OE}}$ input; V <sub>CC</sub> = 0 V, 2.7 V, 3.6; V <sub>I</sub> = GND to 3.6 V	-	0.01	-	-	±1	µA

**Table 7. Static characteristics ...continued**  
 At recommended operating conditions; voltages are referenced to GND (ground 0 V).

Symbol	Parameter	Conditions	T <sub>amb</sub> = 25 °C			T <sub>amb</sub> = -40 °C to +85 °C		Unit
			Min	Typ	Max	Min	Max	
I <sub>OFF</sub>	power-off leakage current	per pin; V <sub>CC</sub> = 0 V						
		V <sub>SW</sub> = 0 V to 2.7 V	-	0.01	-	-	±2.0	μA
		V <sub>SW</sub> = 0 V to 3.6 V	-	0.01	-	-	±2.0	μA
		V <sub>SW</sub> = 0 V to 5.25 V	-	0.01	-	-	±3.0	μA
I <sub>S(OFF)</sub>	OFF-state leakage current	nD+ and nD- ports; see <a href="#">Figure 4</a>						
		V <sub>CC</sub> = 2.7 V, 3.6 V	-	-	-	-	±1	μA
I <sub>CC</sub>	supply current	V <sub>CC</sub> = 2.7 V, 3.6 V						
		$\overline{OE}$ = GND	-	18.5	-	-	30	μA
		$\overline{OE}$ = V <sub>CC</sub> (low-power mode)	-	0.01	-	-	2	μA
ΔI <sub>CC</sub>	additional supply current	S, $\overline{OE}$ input; one input at 1.8 V; other inputs at GND or V <sub>CC</sub>						
		V <sub>CC</sub> = 2.7 V	-	0.8	-	-	1.8	μA
		V <sub>CC</sub> = 3.6 V	-	12.5	-	-	20	μA
C <sub>I</sub>	input capacitance	V <sub>SW</sub> = GND or V <sub>CC</sub> ; V <sub>CC</sub> = 2.5 V, 3.3 V	-	1	-	-	2.5	pF
C <sub>S(OFF)</sub>	OFF-state capacitance	V <sub>SW</sub> = GND or V <sub>CC</sub> ; V <sub>CC</sub> = 2.5 V, 3.3 V	-	3	-	-	5.0	pF
C <sub>S(ON)</sub>	ON-state capacitance	V <sub>SW</sub> = GND or V <sub>CC</sub> ; V <sub>CC</sub> = 2.5 V, 3.3 V	-	6	-	-	7.5	pF

11.1 Test circuits

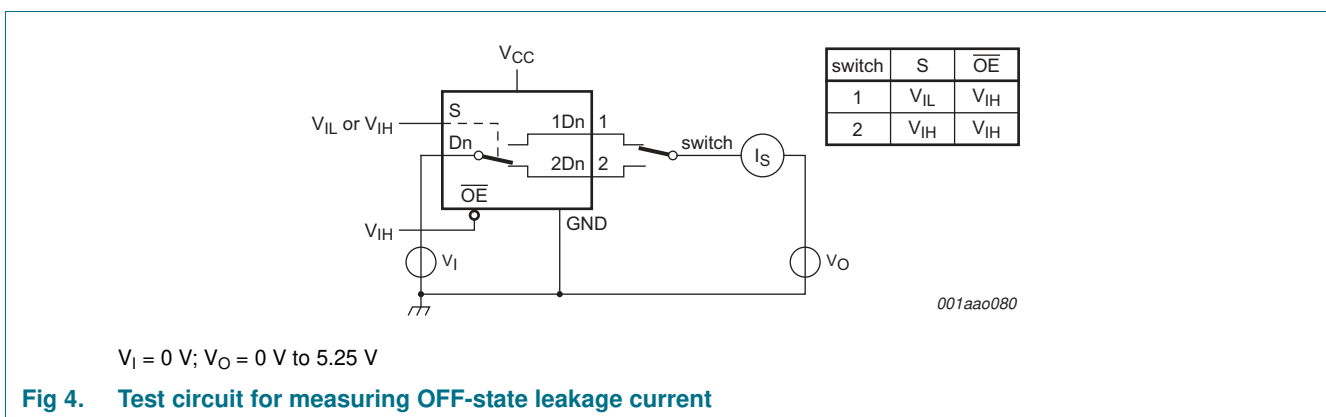

### 11.2 ON resistance

**Table 8. ON resistance**

At recommended operating conditions; voltages are referenced to GND (ground = 0 V); for graphs see [Figure 6](#).

Symbol	Parameter	Conditions	T <sub>amb</sub> = -40 °C to +85 °C			T <sub>amb</sub> = -40 °C to +85 °C		Unit
			Min	Typ <sup>[1]</sup>	Max	Min	Max	
R <sub>ON</sub>	ON resistance	V <sub>CC</sub> = 2.3 V, 3.0 V see <a href="#">Figure 5</a>						
		V <sub>I</sub> = 0 V; I <sub>I</sub> = 30 mA	-	3.6	-	-	6	Ω
		V <sub>I</sub> = 2.4 V; I <sub>I</sub> = -15 mA	-	4.3	-	-	7	Ω
ΔR <sub>ON</sub>	ON resistance mismatch between channels	V <sub>CC</sub> = 2.3 V, 3.0 V <a href="#">[2]</a>						
		V <sub>I</sub> = 0 V; I <sub>I</sub> = 30 mA	-	0.1	-	-	-	Ω
		V <sub>I</sub> = 1.7 V; I <sub>I</sub> = -15 mA	-	0.1	-	-	-	Ω
R <sub>ON(flat)</sub>	ON resistance (flatness)	V <sub>CC</sub> = 2.3 V, 3.0 V; <a href="#">[3]</a> V <sub>I</sub> = 0 V to V <sub>CC</sub>						
		I <sub>I</sub> = 30 mA	-	0.8	-	-	-	Ω
		I <sub>I</sub> = -15 mA	-	0.7	-	-	-	Ω

- [1] Typical values are measured at T<sub>amb</sub> = 25 °C.
- [2] Measured at identical V<sub>CC</sub>, temperature and input voltage.
- [3] Flatness is defined as the difference between the maximum and minimum value of ON resistance measured at identical V<sub>CC</sub> and temperature.

### 11.3 ON resistance test circuit and waveforms

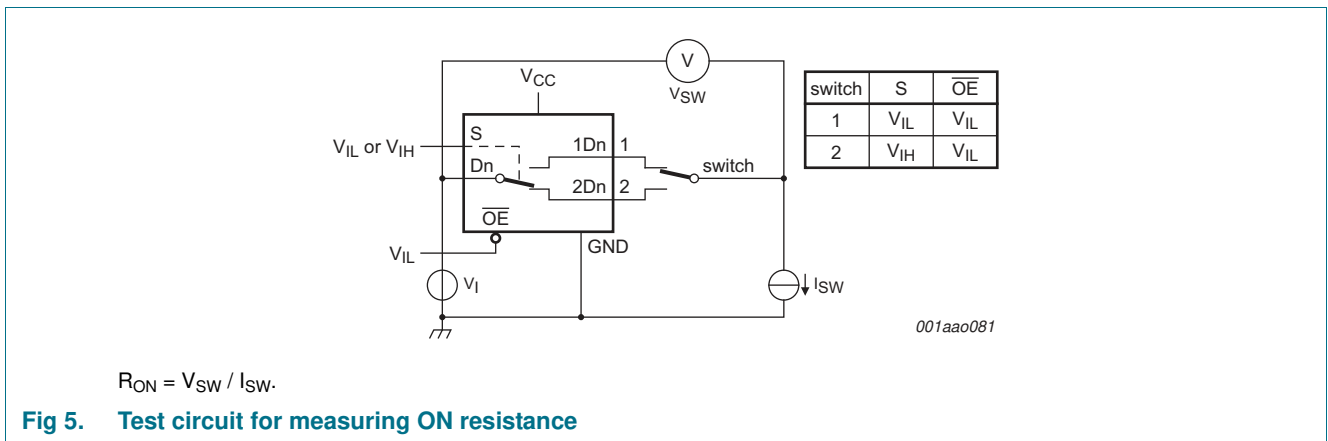

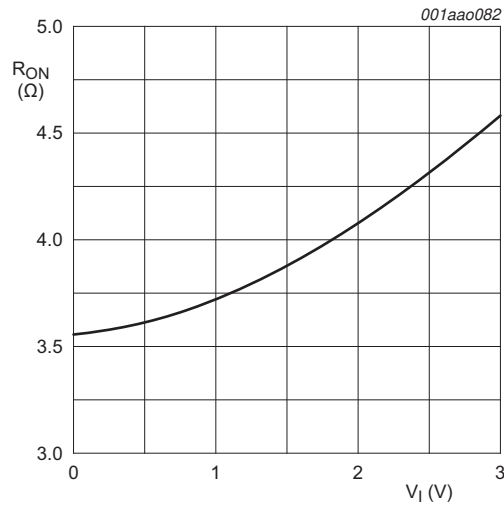

Fig 6. ON resistance as a function of input voltage

## 12. Dynamic characteristics

Table 9. Dynamic characteristics

At recommended operating conditions; voltages are referenced to GND (ground = 0 V); for test circuit, see Figure 10.

Symbol	Parameter	Conditions	T <sub>amb</sub> = 25 °C			T <sub>amb</sub> = -40 °C to +85 °C		Unit
			Min	Typ <sup>[1]</sup>	Max	Min	Max	
t <sub>pd</sub>	propagation delay	Dn to nDn or nDn to Dn; see Figure 7 [2][3]	-	0.25	-	-	-	ns
		V <sub>CC</sub> = 2.3 V to 2.7 V	-	0.25	-	-	-	ns
		V <sub>CC</sub> = 3.0 V to 3.6 V	-	0.25	-	-	-	ns
t <sub>en</sub>	enable time	S to Dn, nDn; see Figure 9 [3]	-	-	-	-	50	ns
		V <sub>CC</sub> = 2.3 V to 2.7 V	-	-	-	-	50	ns
		V <sub>CC</sub> = 3.0 V to 3.6 V	-	-	-	-	30	ns
		OE to Dn, nDn; see Figure 9 [3]	-	-	-	-	32	ns
		V <sub>CC</sub> = 2.3 V to 2.7 V	-	-	-	-	32	ns
		V <sub>CC</sub> = 3.0 V to 3.6 V	-	-	-	-	17	ns
t <sub>dis</sub>	disable time	S to Dn, nDn; see Figure 9 [3]	-	-	-	-	23	ns
		V <sub>CC</sub> = 2.3 V to 2.7 V	-	-	-	-	23	ns
		V <sub>CC</sub> = 3.0 V to 3.6 V	-	-	-	-	12	ns
		OE to Dn, nDn; see Figure 9 [3]	-	-	-	-	12	ns
		V <sub>CC</sub> = 2.3 V to 2.7 V	-	-	-	-	12	ns
		V <sub>CC</sub> = 3.0 V to 3.6 V	-	-	-	-	10	ns

**Table 9. Dynamic characteristics ...continued**

At recommended operating conditions; voltages are referenced to GND (ground = 0 V); for test circuit, see [Figure 10](#).

Symbol	Parameter	Conditions	T <sub>amb</sub> = 25 °C			T <sub>amb</sub> = -40 °C to +85 °C		Unit	
			Min	Typ <sup>[1]</sup>	Max	Min	Max		
t <sub>sk(o)</sub>	output skew time	see <a href="#">Figure 8</a>							
			V <sub>CC</sub> = 2.3 V to 2.7 V	-	0.1	-	-	0.2	ns
			V <sub>CC</sub> = 3.0 V to 3.6 V	-	0.1	-	-	0.2	ns
t <sub>sk(p)</sub>	pulse skew time	see <a href="#">Figure 7</a>							
			V <sub>CC</sub> = 2.3 V to 2.7 V	-	0.1	-	-	0.2	ns
			V <sub>CC</sub> = 3.0 V to 3.6 V	-	0.1	-	-	0.2	ns

- [1] Typical values are measured at T<sub>amb</sub> = 25 °C and V<sub>CC</sub> = 2.5 V and 3.3 V respectively.
- [2] The propagation delay is the calculated RC time constant of the typical ON resistance of the switch and the specified load capacitance, when driven by an ideal voltage source (zero output impedance).
- [3] t<sub>pd</sub> is the same as t<sub>PLH</sub> and t<sub>PHL</sub>.
- [4] Guaranteed by design.

### 12.1 Waveforms, test circuit and graphs

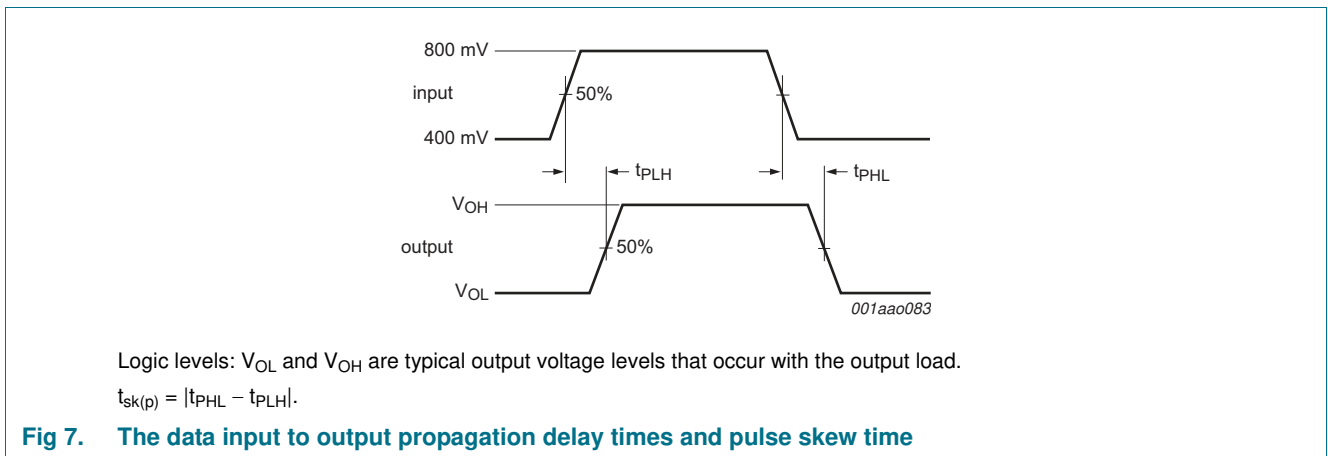



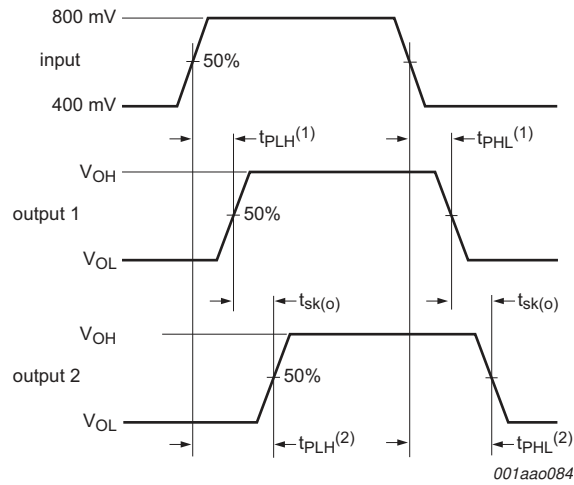

Logic levels:  $V_{OL}$  and  $V_{OH}$  are typical output voltage levels that occur with the output load.  
 $t_{sk(o)} = |t_{PLH(1)} - t_{PLH(2)}|$  or  $|t_{PHL(1)} - t_{PHL(2)}|$ .

**Fig 8. Output skew time**

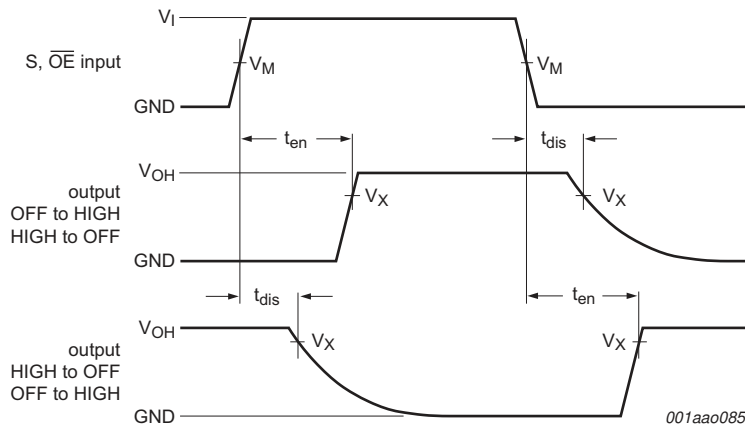

Measurement points are given in [Table 10](#).  
 Logic levels:  $V_{OL}$  and  $V_{OH}$  are typical output voltage levels that occur with the output load.

**Fig 9. Enable and disable times**

**Table 10. Measurement points**

Supply voltage	Input		Output
$V_{CC}$	$V_M$	$V_I$	$V_X$
2.3 V to 3.6 V	$0.5V_I$	1.8 V	$0.9V_{OH}$

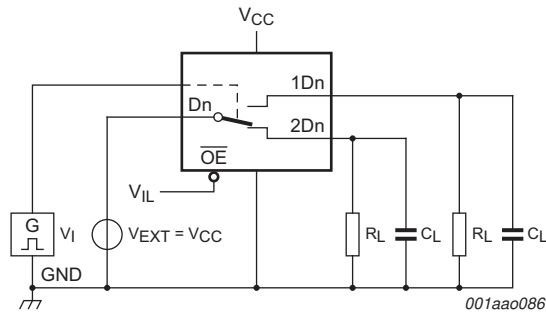

Test data is given in [Table 11](#).

Definitions test circuit:

$R_L$  = Load resistance.

$C_L$  = Load capacitance including jig and probe capacitance.

$V_{EXT}$  = External voltage for measuring switching times.

$V_I$  may be connected to S or  $\overline{OE}$ .

**Fig 10. Test circuit for switching times**

**Table 11. Test data**

Supply voltage	Input		Load	
$V_{CC}$	$V_I$	$t_r, t_f$	$C_L$	$R_L$
2.3 V to 3.6 V	1.8 V	$\leq 5$ ns	50 pF	500 $\Omega$

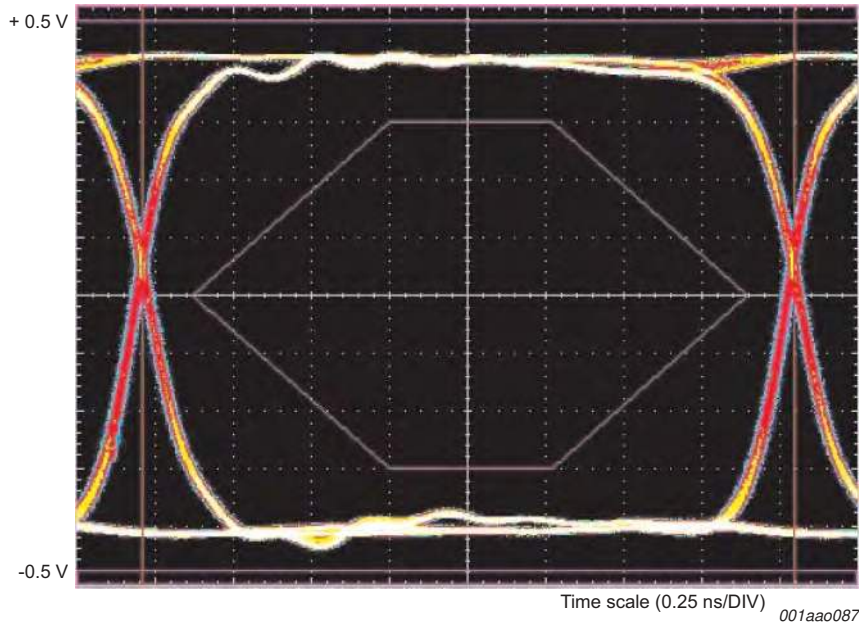

**Fig 11. Eye-pattern 480 Mbps USB signal with no switch.**

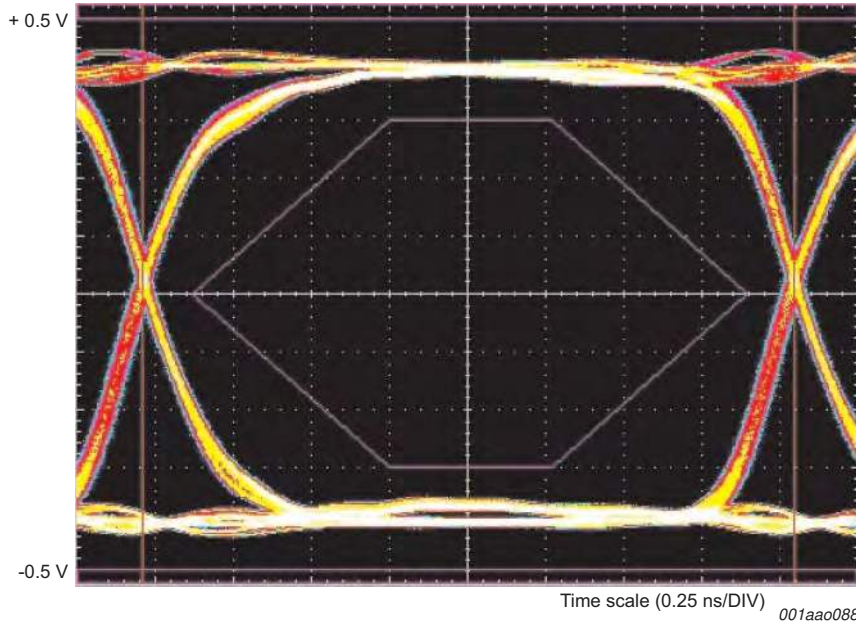

Fig 12. Eye-pattern 480 Mbps USB signal with switch (normally closed path)

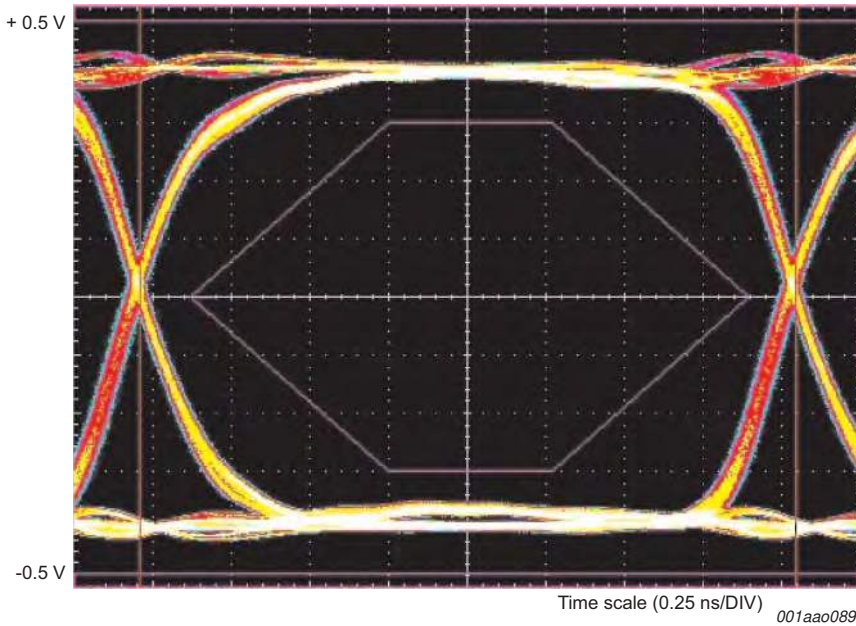

Fig 13. Eye-pattern 480 Mbps USB signal with switch (normally open path)

12.2 Additional dynamic characteristics

Table 12. Additional dynamic characteristics

At recommended operating conditions; voltages are referenced to GND (ground = 0 V);  $V_i = GND$  or  $V_{CC}$  (unless otherwise specified);  $t_r = t_f \leq 5$  ns;  $T_{amb} = 25$  °C.

Symbol	Parameter	Conditions	Min	Typ	Max	Unit
$f_{(-3dB)}$	-3 dB frequency response	$R_L = 50 \Omega$ ; see <a href="#">Figure 14</a>	<a href="#">[1][2]</a>			
		$V_{CC} = 2.3$ V to 2.7 V	-	1.0	-	GHz
		$V_{CC} = 3.0$ V to 3.6 V	-	1.0	-	GHz
$\alpha_{iso}$	isolation (OFF-state)	$f_i = 250$ MHz; $R_L = 50 \Omega$ ; see <a href="#">Figure 15</a>	<a href="#">[1][2]</a>			
		$V_{CC} = 2.3$ V to 2.7 V	-	-38	-	dB
		$V_{CC} = 3.0$ V to 3.6 V	-	-38	-	dB
Xtalk	crosstalk	between switches; $f_i = 250$ MHz; $R_L = 50 \Omega$ ; see <a href="#">Figure 16</a>	<a href="#">[1][2]</a>			
		$V_{CC} = 2.3$ V to 2.7 V	-	-40	-	dB
		$V_{CC} = 3.0$ V to 3.6 V	-	-40	-	dB

[1]  $f_i$  is biased at 350 mV.

[2]  $V_i = 632$  mV (p-p).

12.3 Test circuits

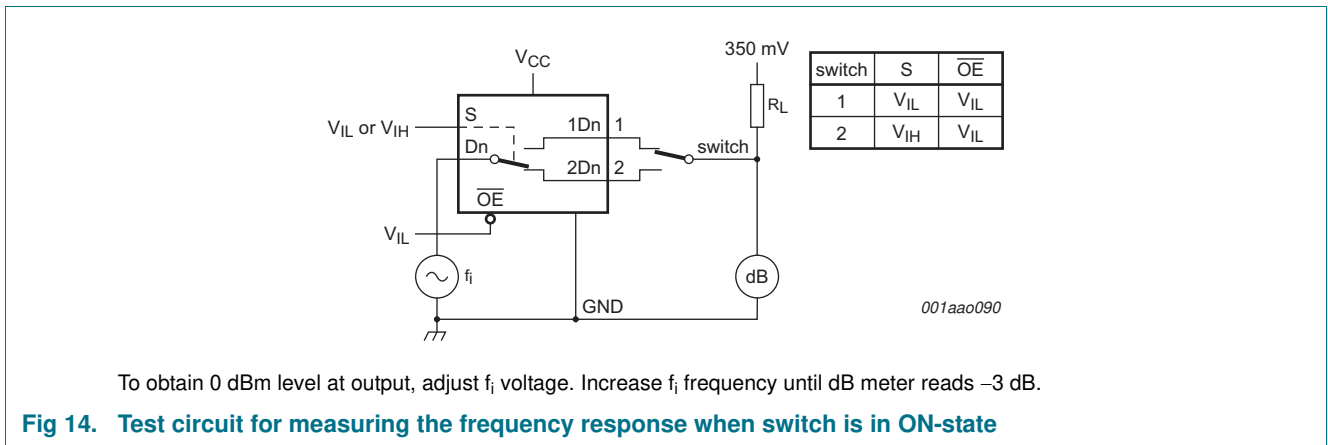

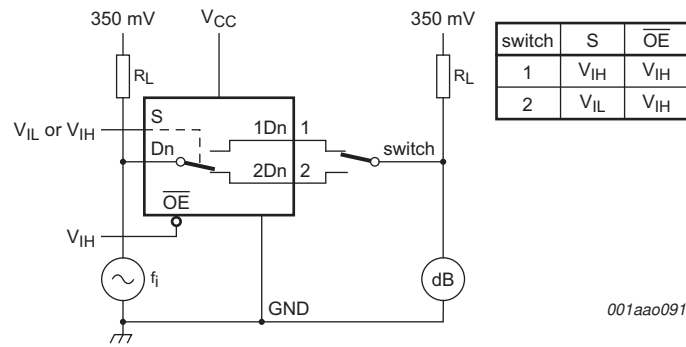

To obtain 0 dBm level at input, adjust  $f_i$  voltage.

Fig 15. Test circuit for measuring isolation (OFF-state)

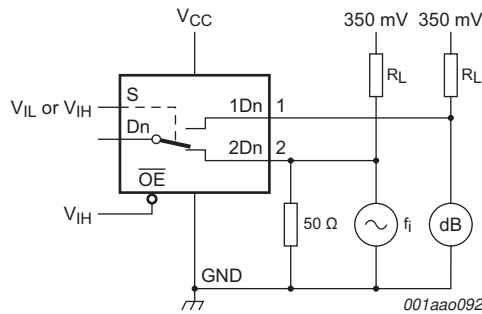

Fig 16. Test circuit for measuring crosstalk

### 13. Package outline

**XQFN10: plastic, extremely thin quad flat package; no leads; 10 terminals; body 1.55 x 2.00 x 0.50 mm**

SOT1049-3

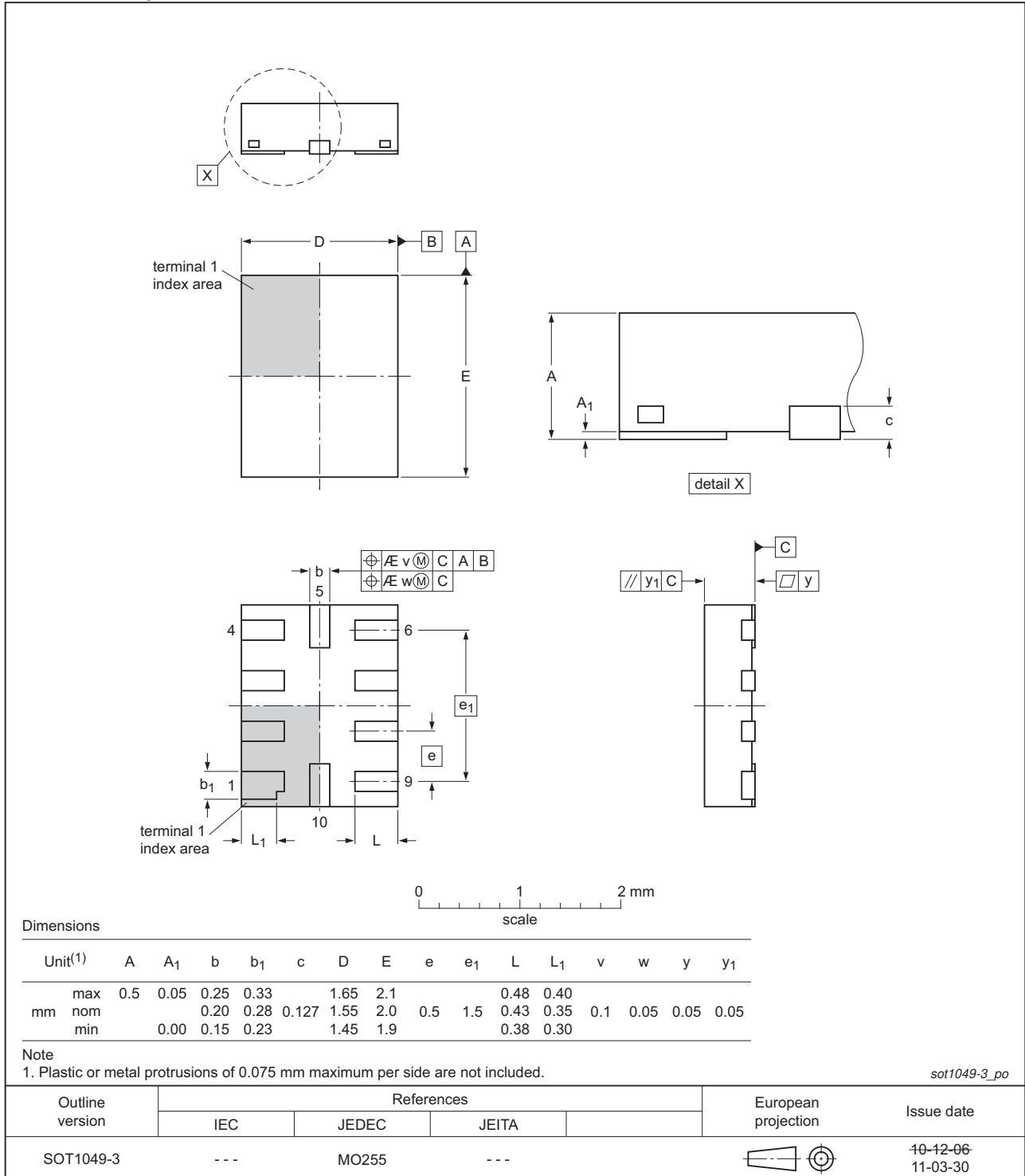

Fig 17. Package outline SOT1049-3 (XQFN10)

HVSON10: plastic thermal enhanced very thin small outline package; no leads;  
10 terminals; 3 x 3 x 0.85 mm

SOT650-2

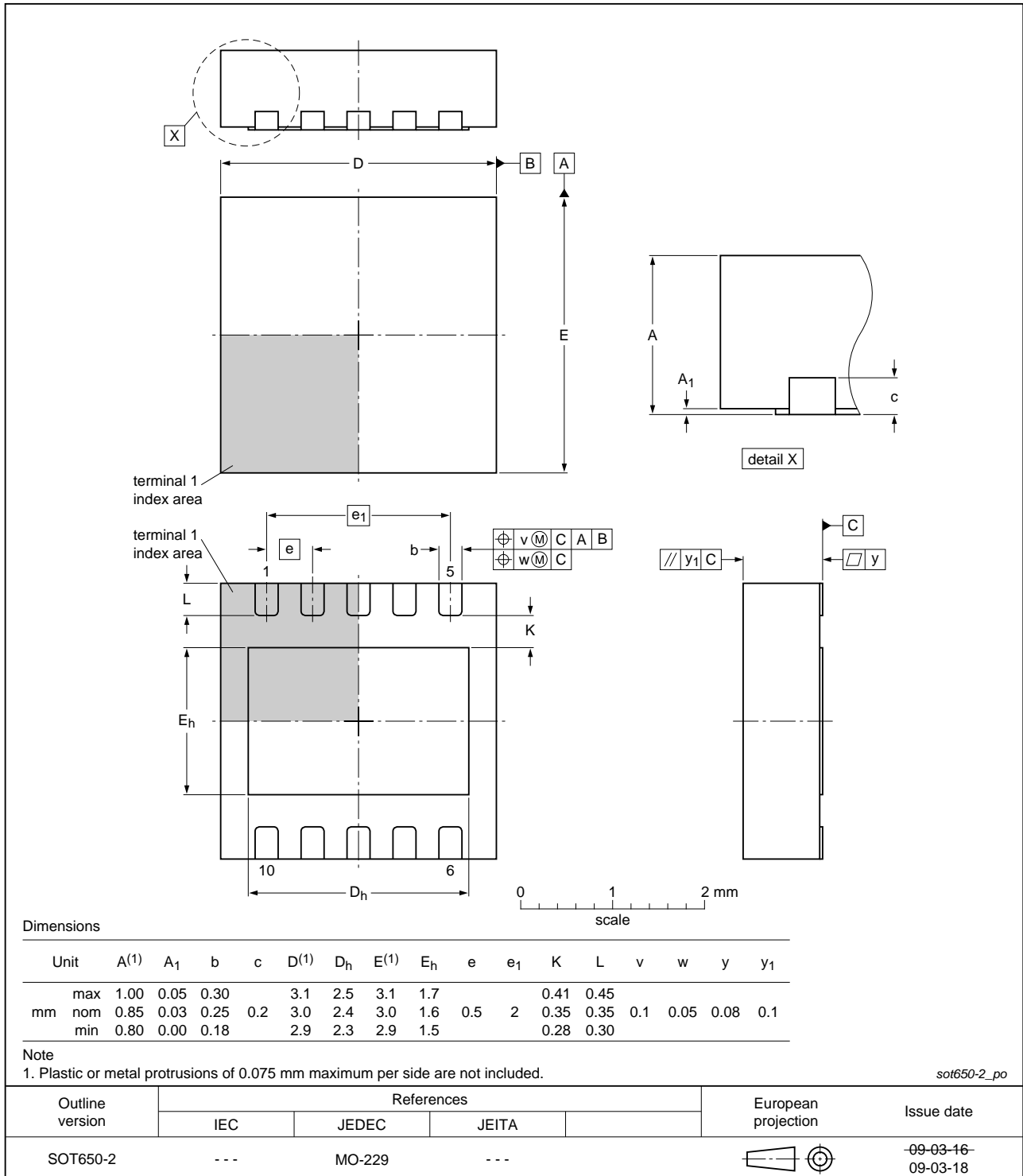

Fig 18. Package outline SOT650-2 (HVSON10)

## 14. Abbreviations

Table 13. Abbreviations

Acronym	Description
CDM	Charged Device Model
CMOS	Complementary Metal Oxide Semiconductor
ESD	ElectroStatic Discharge
HBM	Human Body Model
MM	Machine Model

## 15. Revision history

Table 14. Revision history

Document ID	Release date	Data sheet status	Change notice	Supersedes
NX3DV221 v.4	20130619	Product data sheet	-	NX3DV221 v.3
Modifications:	<ul style="list-style-type: none"><li>Type number NX3DV221TK added.</li><li>Package outline drawing added (<a href="#">Figure 18</a>).</li></ul>			
NX3DV221 v.3	20120705	Product data sheet	-	NX3DV221 v.2
NX3DV221 v.2	20111109	Product data sheet	-	NX3DV221 v.1
NX3DV221 v.1	20110421	Product data sheet	-	-



## 16. Legal information

### 16.1 Data sheet status

Document status <sup>[1][2]</sup>	Product status <sup>[3]</sup>	Definition
Objective [short] data sheet	Development	This document contains data from the objective specification for product development.
Preliminary [short] data sheet	Qualification	This document contains data from the preliminary specification.
Product [short] data sheet	Production	This document contains the product specification.

[1] Please consult the most recently issued document before initiating or completing a design.

[2] The term 'short data sheet' is explained in section "Definitions".

[3] The product status of device(s) described in this document may have changed since this document was published and may differ in case of multiple devices. The latest product status information is available on the Internet at URL <http://www.nxp.com>.

### 16.2 Definitions

**Draft** — The document is a draft version only. The content is still under internal review and subject to formal approval, which may result in modifications or additions. NXP Semiconductors does not give any representations or warranties as to the accuracy or completeness of information included herein and shall have no liability for the consequences of use of such information.

**Short data sheet** — A short data sheet is an extract from a full data sheet with the same product type number(s) and title. A short data sheet is intended for quick reference only and should not be relied upon to contain detailed and full information. For detailed and full information see the relevant full data sheet, which is available on request via the local NXP Semiconductors sales office. In case of any inconsistency or conflict with the short data sheet, the full data sheet shall prevail.

**Product specification** — The information and data provided in a Product data sheet shall define the specification of the product as agreed between NXP Semiconductors and its customer, unless NXP Semiconductors and customer have explicitly agreed otherwise in writing. In no event however, shall an agreement be valid in which the NXP Semiconductors product is deemed to offer functions and qualities beyond those described in the Product data sheet.

### 16.3 Disclaimers

**Limited warranty and liability** — Information in this document is believed to be accurate and reliable. However, NXP Semiconductors does not give any representations or warranties, expressed or implied, as to the accuracy or completeness of such information and shall have no liability for the consequences of use of such information. NXP Semiconductors takes no responsibility for the content in this document if provided by an information source outside of NXP Semiconductors.

In no event shall NXP Semiconductors be liable for any indirect, incidental, punitive, special or consequential damages (including - without limitation - lost profits, lost savings, business interruption, costs related to the removal or replacement of any products or rework charges) whether or not such damages are based on tort (including negligence), warranty, breach of contract or any other legal theory.

Notwithstanding any damages that customer might incur for any reason whatsoever, NXP Semiconductors' aggregate and cumulative liability towards customer for the products described herein shall be limited in accordance with the *Terms and conditions of commercial sale* of NXP Semiconductors.

**Right to make changes** — NXP Semiconductors reserves the right to make changes to information published in this document, including without limitation specifications and product descriptions, at any time and without notice. This document supersedes and replaces all information supplied prior to the publication hereof.

**Suitability for use** — NXP Semiconductors products are not designed, authorized or warranted to be suitable for use in life support, life-critical or safety-critical systems or equipment, nor in applications where failure or malfunction of an NXP Semiconductors product can reasonably be expected to result in personal injury, death or severe property or environmental damage. NXP Semiconductors and its suppliers accept no liability for inclusion and/or use of NXP Semiconductors products in such equipment or applications and therefore such inclusion and/or use is at the customer's own risk.

**Applications** — Applications that are described herein for any of these products are for illustrative purposes only. NXP Semiconductors makes no representation or warranty that such applications will be suitable for the specified use without further testing or modification.

Customers are responsible for the design and operation of their applications and products using NXP Semiconductors products, and NXP Semiconductors accepts no liability for any assistance with applications or customer product design. It is customer's sole responsibility to determine whether the NXP Semiconductors product is suitable and fit for the customer's applications and products planned, as well as for the planned application and use of customer's third party customer(s). Customers should provide appropriate design and operating safeguards to minimize the risks associated with their applications and products.

NXP Semiconductors does not accept any liability related to any default, damage, costs or problem which is based on any weakness or default in the customer's applications or products, or the application or use by customer's third party customer(s). Customer is responsible for doing all necessary testing for the customer's applications and products using NXP Semiconductors products in order to avoid a default of the applications and the products or of the application or use by customer's third party customer(s). NXP does not accept any liability in this respect.

**Limiting values** — Stress above one or more limiting values (as defined in the Absolute Maximum Ratings System of IEC 60134) will cause permanent damage to the device. Limiting values are stress ratings only and (proper) operation of the device at these or any other conditions above those given in the Recommended operating conditions section (if present) or the Characteristics sections of this document is not warranted. Constant or repeated exposure to limiting values will permanently and irreversibly affect the quality and reliability of the device.

**Terms and conditions of commercial sale** — NXP Semiconductors products are sold subject to the general terms and conditions of commercial sale, as published at <http://www.nxp.com/profile/terms>, unless otherwise agreed in a valid written individual agreement. In case an individual agreement is concluded only the terms and conditions of the respective agreement shall apply. NXP Semiconductors hereby expressly objects to applying the customer's general terms and conditions with regard to the purchase of NXP Semiconductors products by customer.

**No offer to sell or license** — Nothing in this document may be interpreted or construed as an offer to sell products that is open for acceptance or the grant, conveyance or implication of any license under any copyrights, patents or other industrial or intellectual property rights.

**Export control** — This document as well as the item(s) described herein may be subject to export control regulations. Export might require a prior authorization from competent authorities.

**Non-automotive qualified products** — Unless this data sheet expressly states that this specific NXP Semiconductors product is automotive qualified, the product is not suitable for automotive use. It is neither qualified nor tested in accordance with automotive testing or application requirements. NXP Semiconductors accepts no liability for inclusion and/or use of non-automotive qualified products in automotive equipment or applications.

In the event that customer uses the product for design-in and use in automotive applications to automotive specifications and standards, customer (a) shall use the product without NXP Semiconductors' warranty of the product for such automotive applications, use and specifications, and (b) whenever customer uses the product for automotive applications beyond

NXP Semiconductors' specifications such use shall be solely at customer's own risk, and (c) customer fully indemnifies NXP Semiconductors for any liability, damages or failed product claims resulting from customer design and use of the product for automotive applications beyond NXP Semiconductors' standard warranty and NXP Semiconductors' product specifications.

**Translations** — A non-English (translated) version of a document is for reference only. The English version shall prevail in case of any discrepancy between the translated and English versions.

## 16.4 Trademarks

Notice: All referenced brands, product names, service names and trademarks are the property of their respective owners.

## 17. Contact information

For more information, please visit: <http://www.nxp.com>

For sales office addresses, please send an email to: [salesaddresses@nxp.com](mailto:salesaddresses@nxp.com)

## 18. Contents

<b>1</b>	<b>General description</b> .....	<b>1</b>
<b>2</b>	<b>Features and benefits</b> .....	<b>1</b>
<b>3</b>	<b>Applications</b> .....	<b>1</b>
<b>4</b>	<b>Ordering information</b> .....	<b>2</b>
<b>5</b>	<b>Marking</b> .....	<b>2</b>
<b>6</b>	<b>Functional diagram</b> .....	<b>2</b>
<b>7</b>	<b>Pinning information</b> .....	<b>3</b>
7.1	Pinning .....	3
7.2	Pin description .....	3
<b>8</b>	<b>Functional description</b> .....	<b>3</b>
<b>9</b>	<b>Limiting values</b> .....	<b>4</b>
<b>10</b>	<b>Recommended operating conditions</b> .....	<b>4</b>
<b>11</b>	<b>Static characteristics</b> .....	<b>4</b>
11.1	Test circuits .....	5
11.2	ON resistance .....	6
11.3	ON resistance test circuit and waveforms .....	6
<b>12</b>	<b>Dynamic characteristics</b> .....	<b>7</b>
12.1	Waveforms, test circuit and graphs .....	8
12.2	Additional dynamic characteristics .....	12
12.3	Test circuits .....	12
<b>13</b>	<b>Package outline</b> .....	<b>14</b>
<b>14</b>	<b>Abbreviations</b> .....	<b>16</b>
<b>15</b>	<b>Revision history</b> .....	<b>16</b>
<b>16</b>	<b>Legal information</b> .....	<b>17</b>
16.1	Data sheet status .....	17
16.2	Definitions .....	17
16.3	Disclaimers .....	17
16.4	Trademarks .....	18
<b>17</b>	<b>Contact information</b> .....	<b>18</b>
<b>18</b>	<b>Contents</b> .....	<b>19</b>

Please be aware that important notices concerning this document and the product(s) described herein, have been included in section 'Legal information'.

© NXP B.V. 2013.

All rights reserved.

For more information, please visit: <http://www.nxp.com>

For sales office addresses, please send an email to: [salesaddresses@nxp.com](mailto:salesaddresses@nxp.com)

Date of release: 19 June 2013

Document identifier: NX3DV221