

This document is the property of Amphenol Corporation and is delivered on the express condition that is not to be disclosed, reproduced or used, in whole or in part, for manufacture or sale by anyone other than Amphenol Corporation without its prior consent, and that no right is granted to disclose or to use any information in this document.
The marking on this product doesn't contain environmental hazardous materials per directive 2011/65/EU for RoHS compliant.

REVISIONS				
SYM	ECN No.	DESCRIPTION	DATE	APPROVED
AX1	EDSR#9393	NON-RELEASE REVISION	08/23/2019	Roger Tsai
AX2	EDSR#9596	UPDATE DRAWING	11/21/2019	Roger Tsai
AX3		UPDATE DRAWING	05/28/2020	Roger Tsai

FOR REFERENCE ONLY

NOTES:

- MATERIAL:
HOUSING: HIGH TEMPERATURE THERMAL PLASTIC LCP UL94-V0,
COLOR: BLACK.
CONTACT TERMINAL: HIGH PERFORMANCE COPPER ALLOY.
GROUND TERMINAL: STAINLESS STEEL.
LATCH: STAINLESS STEEL.
SHELL: STAINLESS STEEL.
- FINISH:
CONTACT TERMINAL:
CONTACT AREA: SELECTIVE PLATING;
SOLDERING AREA: GOLD FLASH PLATING. ;
UNDER PLATING: NICKEL PLATING 50 μ m THICKNESS MIN.OVERALL.
GROUND TERMINAL:
SOLDERING AREA: GOLD FLASH PLATING. ;
UNDER PLATING: NICKEL PLATING 10 μ m THICKNESS MIN.OVERALL.
SHELL:
SOLDERING AREA: GOLD FLASH PLATING. ;
UNDER PLATING: NICKEL PLATING 10 μ m THICKNESS MIN.OVERALL.
- PRODUCT SPECIFICATION REFER TO : PS-7787.
- TEST SUMMARY REFER TO : TS-7787.
- THIS PRODUCT DOESN'T CONTAIN ENVIRONMENTAL HAZARDOUS PER DIRECTIVE 2011/65/EU FOR RoHS COMPLIANT OR PER IEC 61249-2-21 FOR HALOGEN-FREE COMPLIANT.

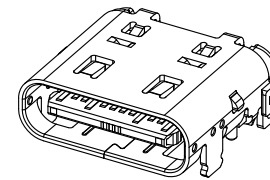
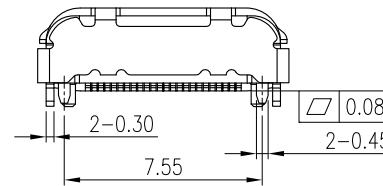
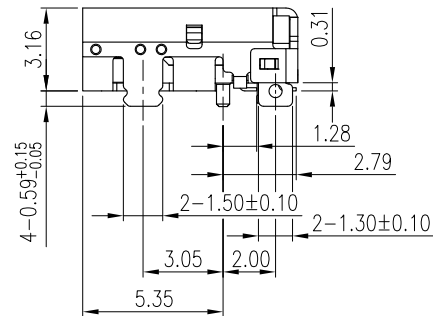
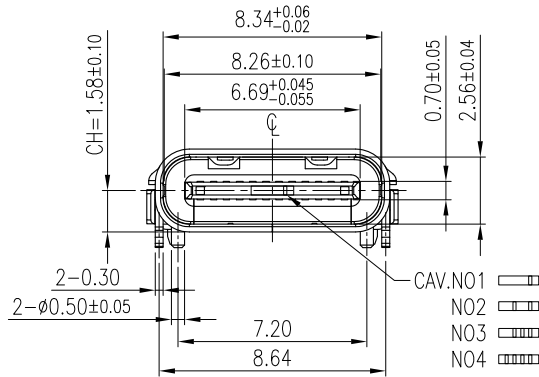
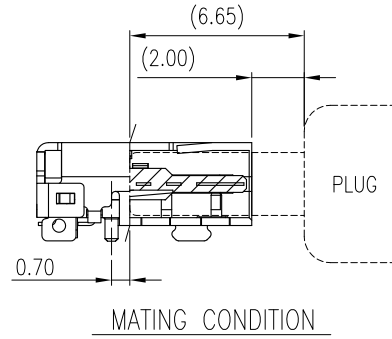
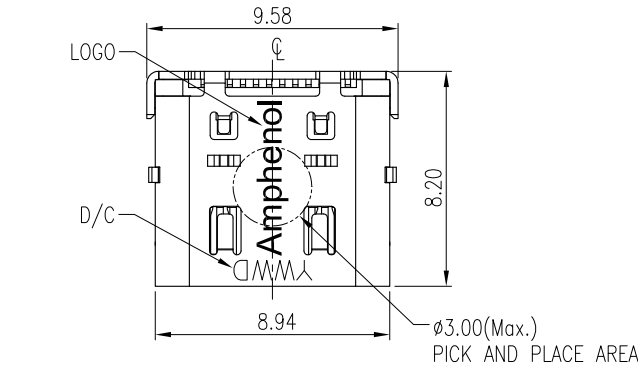

P/N : GSB4D31 X 302Y1HR
CONTACT FINISH
3: 30 μ m GOLD

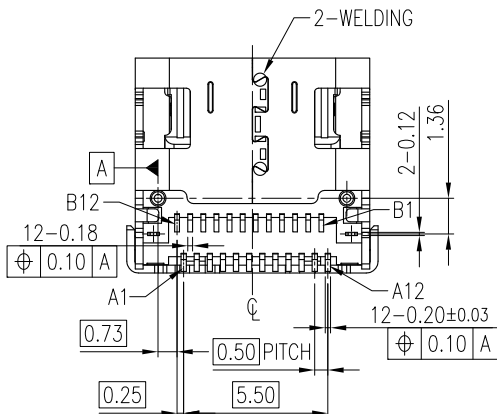

TOLERANCE	APPROVALS	DATE	TITLE	UNIT		SIZE	PART No.
X. ±0.30	DRAWN Karen Su	05/28/2020	USB TYPE-C ACCORD WITH USB4 GEN3 RECEPTACLE R/A DUAL ROW SMT TYPE, CH=1.58mm	mm	A3	GSB4D31X302Y1HR	
X.X ±0.20	CHECKED Aqua Chou	05/28/2020		SCALE	SHEET		
X.XXX ±0.10	APPROVED Roger Tsai	05/28/2020		NA	1 OF 3		
ANGULAR ±1°	DWG TYPE CUST DWG	PROJECT CODE OTHER		DWG No. GSB4D31X302Y1HR			REV. AX3
UNLESS OTHERWISE SPECIFIED							

This document is the property of Amphenol Corporation and is delivered on the express condition that is not to be disclosed, reproduced or used, in whole or in part, for manufacture or sale by anyone other than Amphenol Corporation without its prior consent, and that no right is granted to disclose or to use any information in this document.
The marking on this product doesn't contain environmental hazardous materials per directive 2011/65/EU for RoHS compliant.

REVISIONS				
SYM	ECN No.	DESCRIPTION	DATE	APPROVED
AX1	EDSR#9393	NON-RELEASE REVISION	08/23/2019	Roger Tsai
AX2	EDSR#9596	UPDATE DRAWING	11/21/2019	Roger Tsai
AX3		UPDATE DRAWING	05/28/2020	Roger Tsai

FOR REFERENCE ONLY

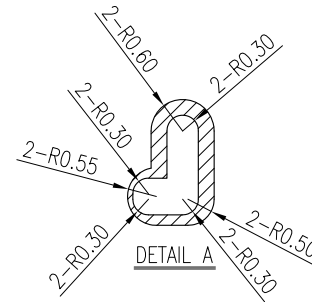
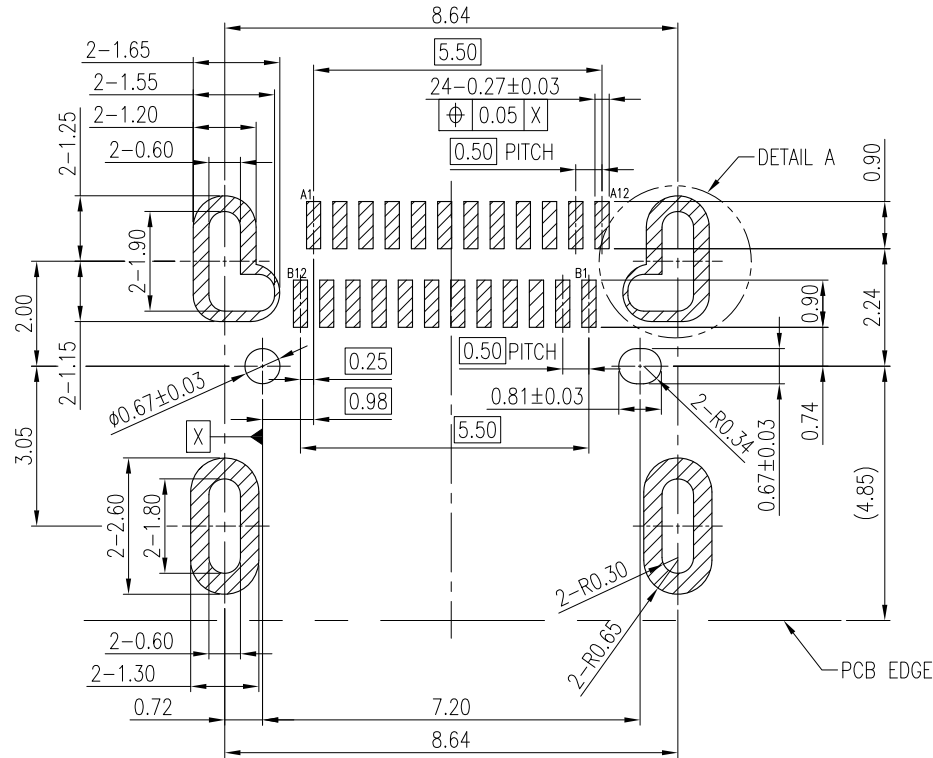

RECOMMENDED PCB LAYOUT (TOP VIEW)

TOLERANCE: ±0.05mm
(PCB THICKNESS 0.80±0.05mm)
SCALE 2:1

▨ BOARD PAD

PIN ASSIGNMENT											
A1	A2	A3	A4	A5	A6	A7	A8	A9	A10	A11	A12
GND	TX1+	TX1-	VBUS	CC1	D+	D-	RFU1	VBUS	RX2-	RX2+	GND
GND	RX1+	RX1-	VBUS	SBU2	D-	D+	CC2	VBUS	TX2-	TX2+	GND
B12	B11	B10	B9	B8	B7	B6	B5	B4	B3	B2	B1

TOLERANCE	APPROVALS	DATE	TITLE		Amphenol®	
X. ±0.30	DRAWN Karen Su	05/28/2020	USB TYPE-C ACCORD WITH USB4 GEN3 RECEPTACLE R/A DUAL ROW SMT TYPE, CH=1.58mm		Amphenol Corporation Amphenol Taiwan Corporation	
X.X ±0.20	CHECKED Aqua Chou	05/28/2020				
X.XXX ±0.10	APPROVED Roger Tsai	05/28/2020				
ANGULAR ±1°	DWG TYPE CUST DWG	PROJECT CODE OTHER	UNIT mm	SIZE A3	PART No. GSB4D31X302Y1HR	
UNLESS OTHERWISE SPECIFIED			SCALE NA	SHEET 2 OF 3	DWG No. GSB4D31X302Y1HR REV. AX3	

This document is the property of Amphenol Corporation and is delivered on the express condition that is not to be disclosed, reproduced or used, in whole or in part, for manufacture or sale by anyone other than Amphenol Corporation without its prior consent, and that no right is granted to disclose or to use any information in this document.
The marking on this product doesn't contain environmental hazardous materials per directive 2011/65/EU for RoHS compliant.

FOR REFERENCE ONLY

REVISIONS				
SYM	ECN No.	DESCRIPTION	DATE	APPROVED
AX1	EDSR#9393	NON-RELEASE REVISION	08/23/2019	Roger Tsai
AX2	EDSR#9596	UPDATE DRAWING	11/21/2019	Roger Tsai
AX3		UPDATE DRAWING	05/28/2020	Roger Tsai

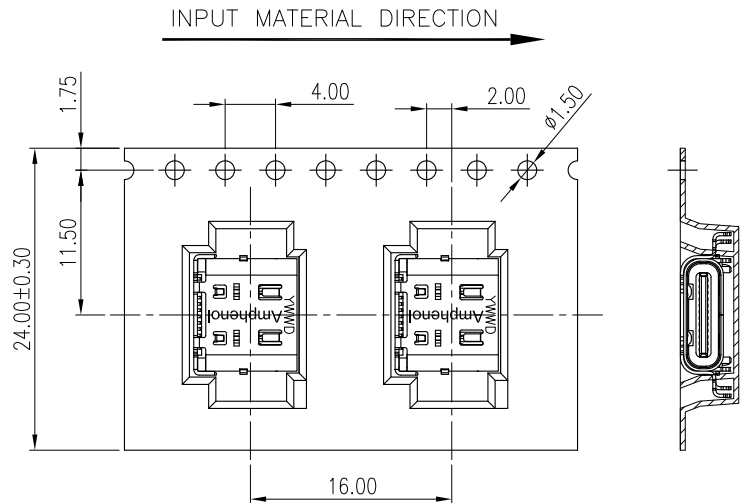
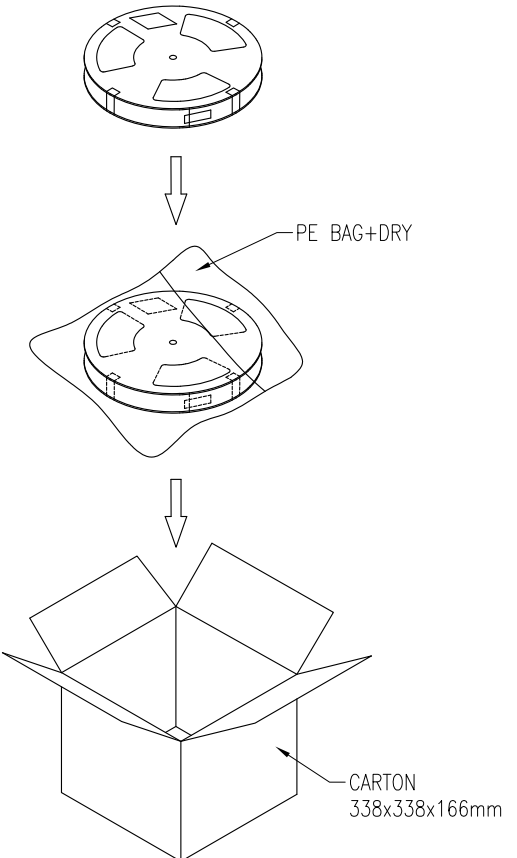
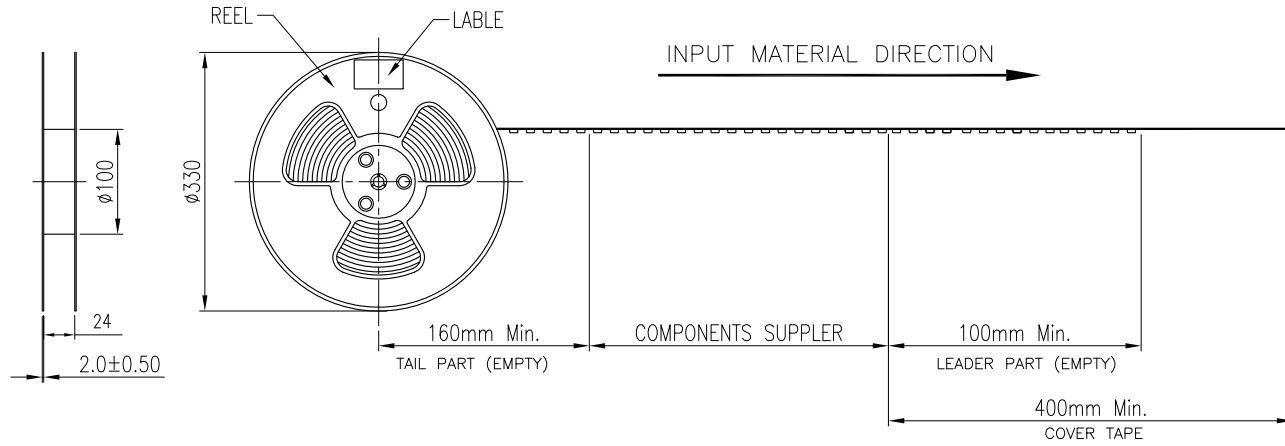

PACKAGING BY T&R	5.5 G/W KG	4.5 N/W KG	700 PCS/ REEL	5 REELS/ BOX	3500 QUANTITY (PCS)	GSB4D31X302Y1HR PART NUMBER
------------------	------------	------------	---------------	--------------	---------------------	-----------------------------

TOLERANCE	APPROVALS	DATE
X. ±0.30	DRAWN Karen Su	05/28/2020
X.X ±0.20	CHECKED Aqua Chou	05/28/2020
X.XXX ±0.10	APPROVED Roger Tsai	05/28/2020
ANGULAR ±1°	DWG TYPE CUST DWG	PROJECT CODE OTHER
UNLESS OTHERWISE SPECIFIED		

TITLE			UNIT		SIZE		PART No.	
USB TYPE-C ACCORD WITH USB4 GEN3 RECEPTACLE R/A DUAL ROW SMT TYPE, CH=1.58mm			mm	A3	GSB4D31X302Y1HR		Amphenol® Amphenol Corporation Amphenol Taiwan Corporation	
UNLESS OTHERWISE SPECIFIED			SCALE NA	SHEET 3 OF 3	GSB4D31X302Y1HR		REV. AX3	