

# PI3EQX1002E

## 1-Port USB3.1 Gen-2 ReDriver

### Features

- 10Gbps serial link with linear equalizer.
- USB3.1 and USB3.0 Compatible
- Full Compliancy to USB3.1 Super Speed Standard
- Two 10Gbps differential signal pairs
- Pin Adjustable Receiver Equalization
- Pin Adjustable output linear swing
- Pin Adjustable Flat Gain
- 100Ω Differential CML I/O's
- Automatic Receiver Detect
- Auto "Slumber" mode for adaptive power management
- Single Supply Voltage: 3.3V
- Patented Technology
- Totally Lead-Free & Fully RoHS Compliant (Notes 1 & 2)
- Halogen and Antimony Free. "Green" Device (Note 3)
- Packaging:
  - 24-pin, TQFN 2.5x2.5 mm (ZR24)

### Block Diagram

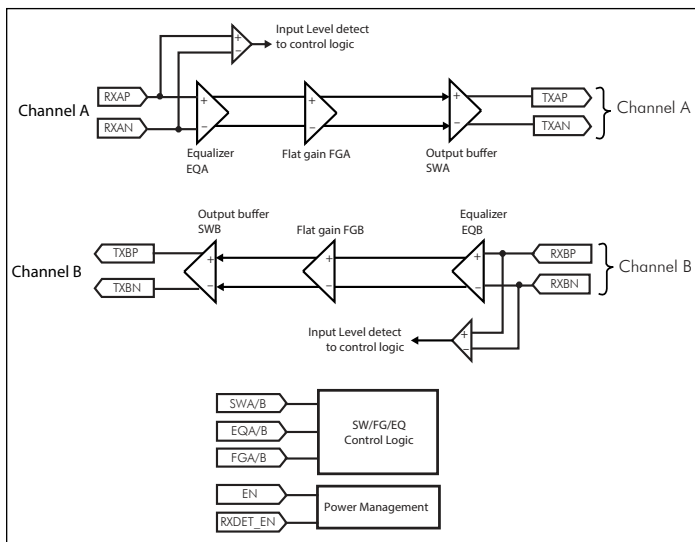

### Description

The PI3EQX1002E is a low power, high performance 10.0 Gbps 1-Port USB 3.1 linear ReDriver™ designed specifically for the USB 3.1 protocol.

The device provides programmable equalization, swing and flat gain to optimize performance over a variety of physical mediums by reducing Inter-Symbol Interference. PI3EQX1002E supports two 100Ω Differential CML data I/O's between the Protocol ASIC to a switch fabric, over cable, or to extend the signals across other distant data pathways on the user's platform.

The integrated equalization circuitry provides flexibility with signal integrity of the signal before the ReDriver. Each channel operates fully independently. The channels' input signal level determines whether the output is active.

The PI3EQX1002E also includes an automatic receiver detect function. The receiver detection loop will be active again if the corresponding channel's signal detector is idle for longer than 7.3mS. The channel will then move to Unplug Mode if load not detected, or it will return to Low Power Mode (Slumber Mode) due to inactivity.

### Block Diagram

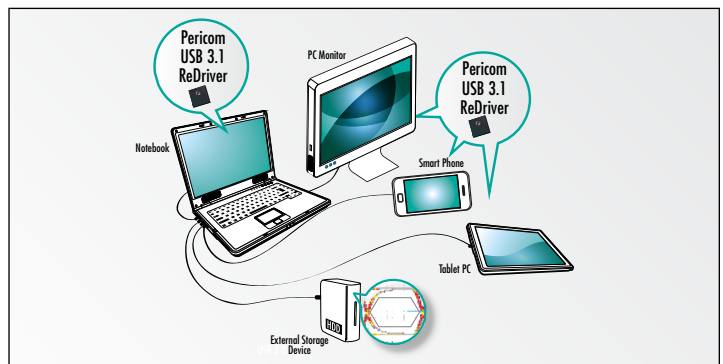

### Ordering Information

Part Number	Package	Description
PI3EQX1002EZREX	ZR	24-Contact, Very Very Thin Quad Flat No-Lead (TQFN)

#### Notes:

1. No purposely added lead. Fully EU Directive 2002/95/EC (RoHS), 2011/65/EU (RoHS 2) & 2015/863/EU (RoHS 3) compliant.
2. See <https://www.diodes.com/quality/lead-free/> for more information about Diodes Incorporated's definitions of Halogen- and Antimony-free, "Green" and Lead-free.
3. Halogen- and Antimony-free "Green" products are defined as those which contain <900ppm bromine, <900ppm chlorine (<1500ppm total Br + Cl) and <1000ppm antimony compounds.
4. E = Pb-free and Green
5. X suffix = Tape/Reel