

NHD-1.8-128160EF-SSXN-F_Rev1B

TFT (Thin-Film Transistor) Liquid Crystal Display Module

NHD-	Newhaven Display
1.8-	1.8" Diagonal
128160-	128 x 160 Pixels (Portrait Mode)
EF-	Model
S-	Built-in Controller, 3/4-wire Serial Interface
S-	Sunlight Readable
X-	TFT
N-	TN, 6:00 Optimal View, Wide Temperature
F-	FFC ZIF Connection Style

Newhaven Display International, Inc.

2661 Galvin Ct.

Elgin IL, 60124

Ph: 847-844-8795

Fax: 847-844-8796

www.newhavendisplay.com

nhtech@newhavendisplay.com

nhsales@newhavendisplay.com

Document Revision History

Revision	Date	Description	Changed by
-	2/27/19	Initial Release	AS
1	6/10/19	Added MPU Interface Summary & Pinout Details	AS
2	10/31/19	Adjusted Viewing Angles	SB
3	2/26/20	FPC Redesign: Pin 12 changed from NC to TE P/N updated to Rev1B	SM
4	8/19/20	Updated Optical Characteristics & Quality Information	AS
5	3/9/21	Updated Silkscreen on FPC & Quality Information	AS

Functions and Features

- 128 x 160 pixels (portrait mode)
- High brightness LED backlight
- Sunlight readable
- 2.8V power supply
- 3/4-wire serial MPU interface
- Built-in ILI9163V controller

Mechanical Drawing

SYMBOL	REVISION	DATE

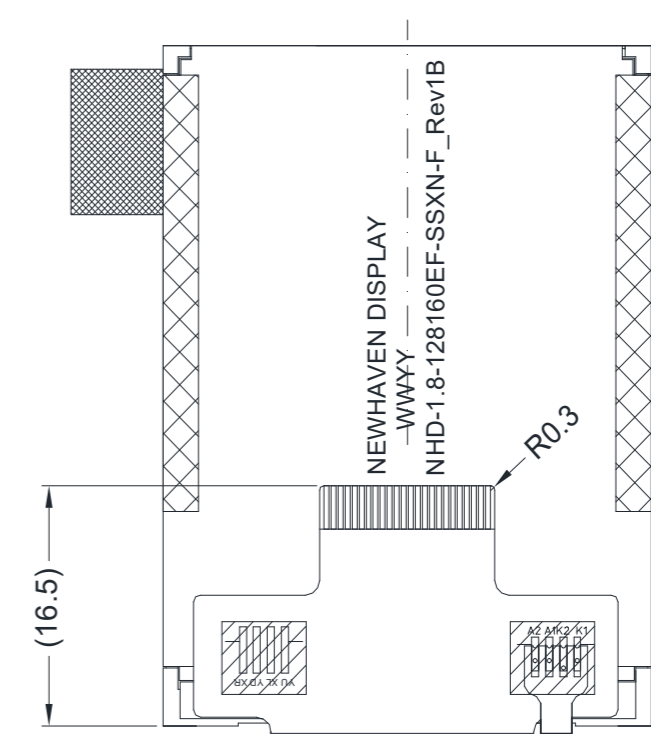
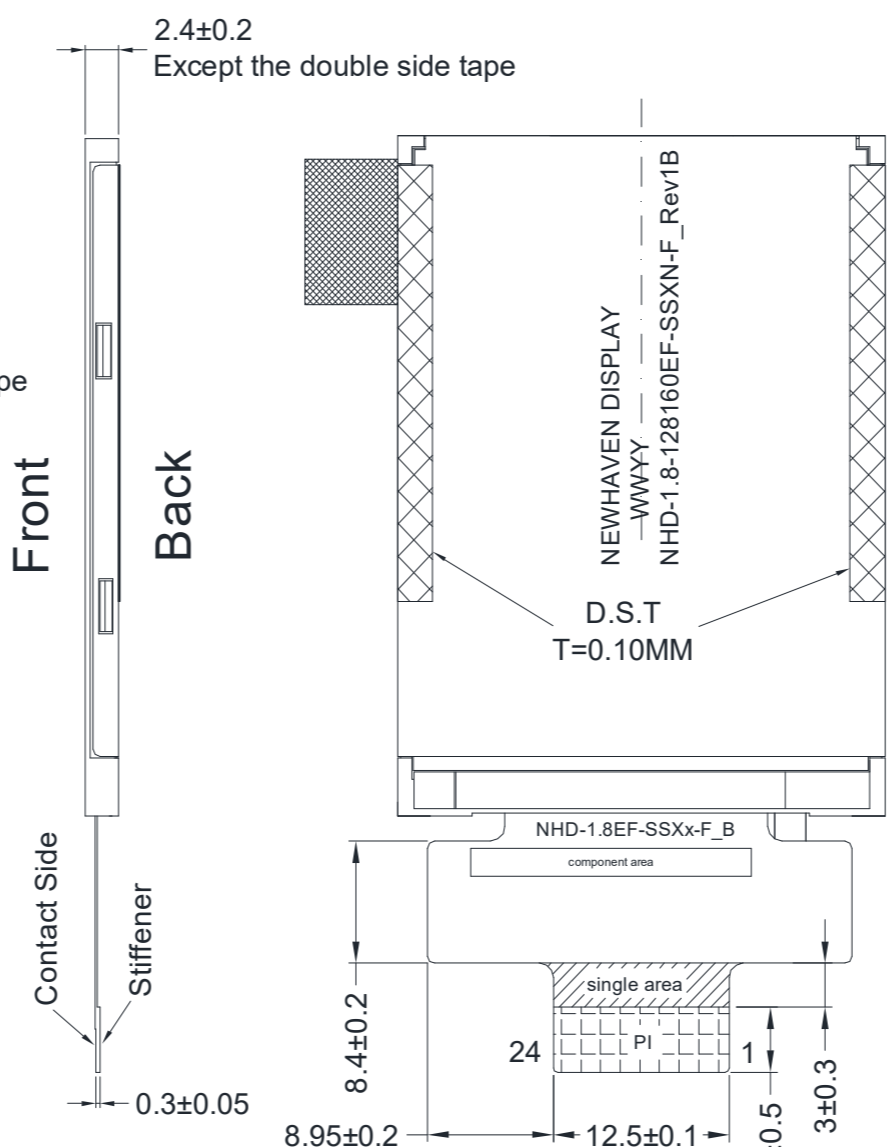
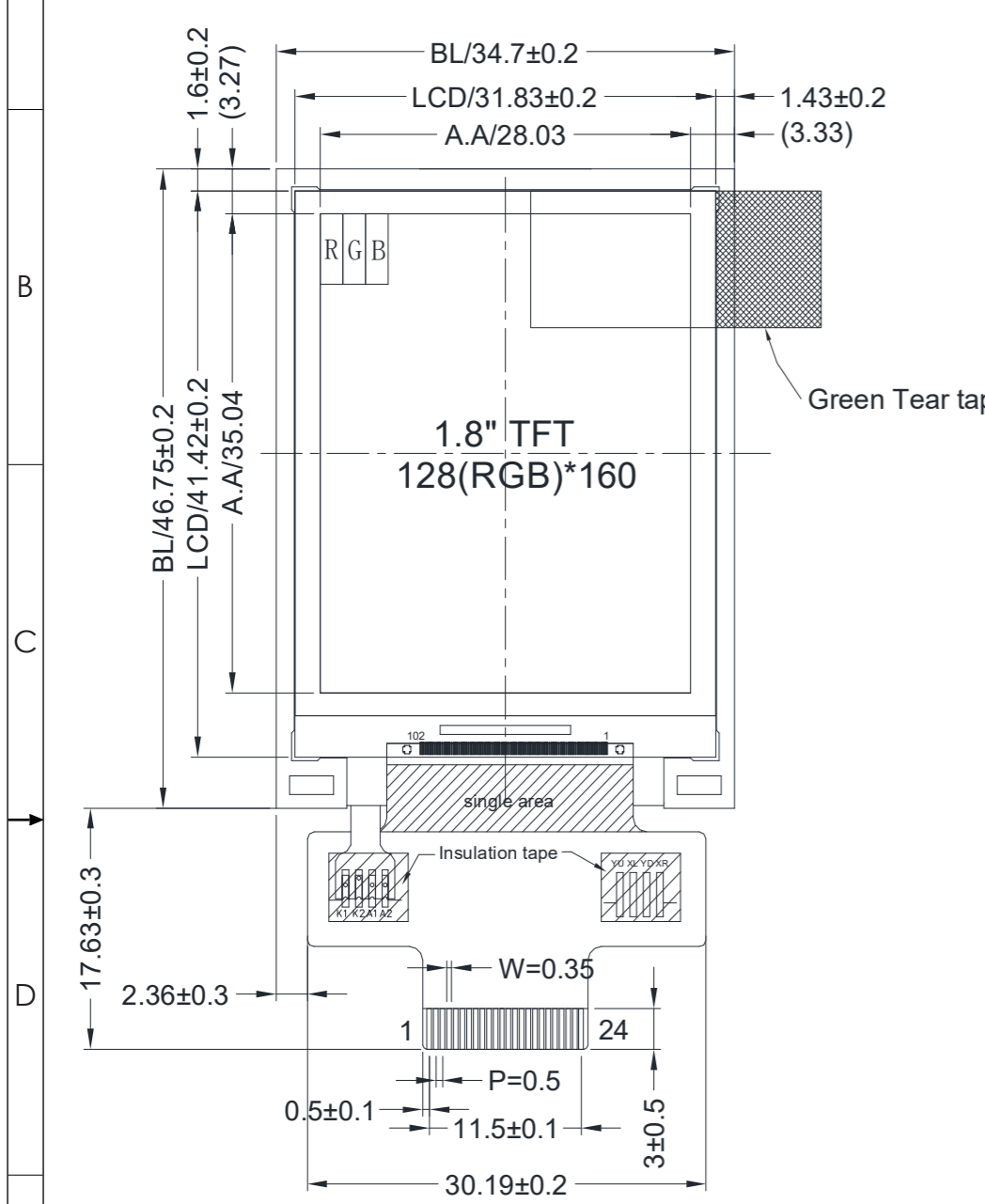

TFT Pinout:

Pin No.	Symbol
1	GND
2	IOVDD
3	VDD
4	/CS
5	/RST
6	SDIO
7	GND
8	D/C
9	SCL
10	GND
11	SPI4W
12	TE
13	NC
14	NC
15	NC
16	NC
17	LED-A
18	LED-K1
19	LED-K2
20	GND
21	NC
22	NC
23	NC
24	NC

- Notes:**
1. Display Size: 1.77" TFT
 2. Optimal View: 6:00
 3. Display Mode: Transmissive /Normal White / Anti-Glare
 4. Driver IC: ILI9163V
 5. Supply Voltage: 2.8 V
 6. Backlight: White LED / 3.2 V / 100 mA (Typ)
 7. Luminance: 1100 cd/m² (Typ)

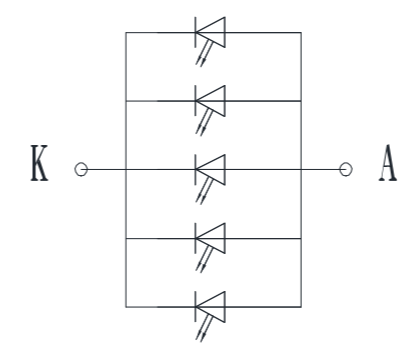

Standard Tolerance: (Unless otherwise specified) Linear: ±0.3mm		
	Drawing/Part Number: NHD-1.8-128160EF-SSXN-F	Revision: 1B
Unless otherwise specified: • Dimensions are in Millimeters • Third Angle Projection	Drawn By: A. Shah	Approved By: A. Shah
	Drawn Date: 3/5/2021	Approved Date: 3/5/2021
Do Not Scale Drawing		Sheet 1 of 1
This drawing is solely the property of Newhaven Display International, Inc. The information it contains is not to be disclosed, reproduced or copied in whole or part without written approval from Newhaven Display.		

Pin Description

Pin No.	Symbol	External Connection	Function Description
1	GND	Power Supply	Ground
2	IOV _{DD}	Power Supply	Supply Voltage for Logic (2.8V) – Can be tied to VDD
3	V _{DD}	Power Supply	Supply Voltage for LCD (2.8V)
4	/CS	MPU	Active LOW Chip Select signal
5	/RST	MPU	Active LOW Reset signal
6	SDIO	MPU	Serial Data Input & Output signal
7	GND	Power Supply	Ground
8	D/C	MPU	Data / Command selection 4-wire Serial: '1' = Data ; '0' = Command 3-wire Serial: Ground
9	SCL	MPU	Serial Clock signal
10	GND	Power Supply	Ground
11	SPI4W	MPU	SPI4W: '1' = 4-wire SPI ; '0' = 3-wire SPI (default)
12	TE	MPU	Tearing Effect output pin to synchronize MCU to frame writing. If not used, leave this pin floating (No Connect)
13-16	NC	-	No Connect
17	LED-A	Power Supply	Backlight Anode (100mA @ 3.2V)
18	LED-K1	Power Supply	Backlight Cathode
19	LED-K2	Power Supply	Backlight Cathode
20	GND	Power Supply	Ground
21-24	NC	-	No Connect

Recommended LCD connector: 24pin 0.5mm FFC connector. Molex P/N: 52435-2471

MPU Interface Pin Assignment Summary

	Pin 4 (/CS)	Pin 6 (SDIO)	Pin 8 (D/C)	Pin 9 (SCL)	Pin 11 (SPI4W)
3-wire SPI (default)	Chip Select	Serial Data I/O	Tie LOW	Serial Clock	0
4-wire SPI	Chip Select	Serial Data I/O	Data/Command	Serial Clock	1

Wiring Diagram

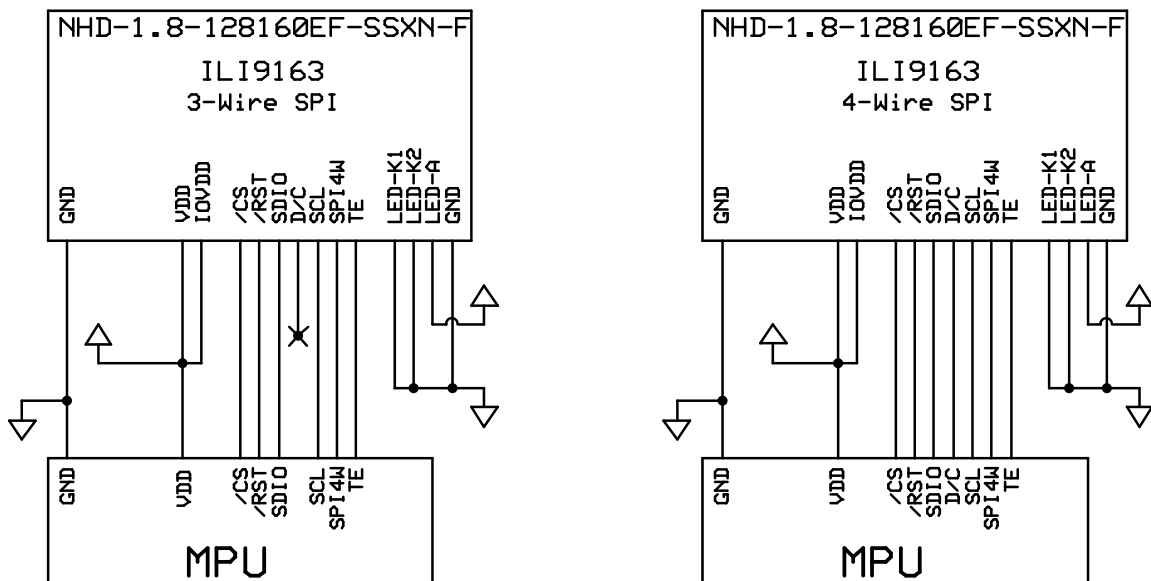

Electrical Characteristics

Item	Symbol	Condition	Min.	Typ.	Max.	Unit
Operating Temperature Range	T _{OP}	Absolute Max	-20	-	+70	°C
Storage Temperature Range	T _{ST}	Absolute Max	-30	-	+80	°C
Supply Voltage for LCD	V _{DD}	-	2.5	2.8	3.3	V
Supply Voltage for Logic	IOV _{DD}	-	1.65	2.8	3.3	V
Supply Current	I _{DD}	V _{DD} = 2.8V	1	3	5	mA
"H" Level input	V _{IH}	-	0.7*IOV _{DD}	-	IOV _{DD}	V
"L" Level input	V _{IL}	-	GND	-	0.3*IOV _{DD}	V
"H" Level output	V _{OH}	-	0.8*IOV _{DD}	-	IOV _{DD}	V
"L" Level output	V _{OL}	-	GND	-	0.2*IOV _{DD}	V
Backlight Supply Current	I _{LED}	-	-	100	125	mA
Backlight Supply Voltage	V _{LED}	I _{LED} = 100mA	2.8	3.2	3.4	V
Backlight Lifetime*	-	I _{LED} = 100mA T _{OP} = 25°C	20,000	30,000	-	Hrs.

*Backlight lifetime is rated as Hours until **half-brightness**, under normal operating conditions. The LED of the backlight is driven by current drain; drive voltage is for reference only. Drive voltage must be selected to ensure backlight current drain is below MAX level stated.

Optical Characteristics

Item	Symbol	Condition	Min.	Typ.	Max.	Unit		
Optimal Viewing Angles	Top	φY+	CR ≥ 10	-	40	-	°	
	Bottom	φY-		-	60	-	°	
	Left	θX-		-	60	-	°	
	Right	θX+		-	60	-	°	
Contrast Ratio	CR	-	400	500	-	-		
Luminance	L _V	I _{LED} =100mA	880	1100	-	cd/m ²		
Response Time	Rise + Fall	T _R +T _F	T _{OP} = 25°C		-	8	16	ms
Chromaticity	Red	X _R	-	0.552	0.602	0.652		
		Y _R		0.321	0.371	0.421		
	Green	X _G		0.266	0.316	0.366		
		Y _G		0.542	0.592	0.642		
	Blue	X _B		0.088	0.138	0.188		
		Y _B		0.049	0.099	0.149		
	White	X _W		0.245	0.295	0.345		
		Y _W		0.288	0.338	0.388		

Controller Information

Built-in ILI9163V controller.

Please download specification at <https://www.newhavendisplay.com/appnotes/datasheets/LCDs/ILI9163V.pdf>

Table of Commands

Hex Code	Command	Description	Number of Parameters	Display Architecture Implementation Requirement		
				Type 1	Type 2	Type 3
00h	nop	No Operation	0	Yes	Yes	Yes
01h	soft_reset	Software Reset	0	Yes	Yes	Yes
06h	get_red_channel	Get the red component of the pixel at (0, 0).	1	No	Yes	Yes
07h	get_green_channel	Get the green component of the pixel at (0, 0).	1	No	Yes	Yes
08h	get_blue_channel	Get the blue component of the pixel at (0, 0).	1	No	Yes	Yes
0Ch	get_pixel_format	Get the current pixel format.	1	Yes	Yes	Yes
0Ah	get_power_mode	Get the current power mode.	1	Yes	Yes	Yes
0Bh	get_address_mode	Get the frame memory to the display panel read order.	1	Yes	Yes	Yes
0Dh	get_display_mode	Get the current display mode from the peripheral.	1	Yes	Yes	Yes
0Eh	get_signal_mode	Get display module signaling mode.	1	Yes	Yes	Yes
0Fh	get_diagnostic_result	Get Peripheral Self-Diagnostic Result	1	Yes	Yes	Yes
10h	enter_sleep_mode	Power for the display panel is off.	0	Yes	Yes	Yes
11h	exit_sleep_mode	Power for the display panel is on.	0	Yes	Yes	Yes
12h	enter_partial_mode	Part of the display area is used for image display.	0	Yes	Yes	No
13h	enter_normal_mode	The whole display area is used for image display.	0	Yes	Yes	No
20h	exit_invert_mode	Displayed image colors are not inverted.	0	Yes	Yes	Yes
21h	enter_invert_mode	Displayed image colors are inverted.	0	Yes	Yes	Yes
26h	set_gamma_curve	Selects the gamma curve used by the display device.	1	Yes	Yes	Yes
28h	set_display_off	Blanks the display device.	0	Yes	Yes	Yes
29h	set_display_on	Show the image on the display device.	0	Yes	Yes	Yes
2Ah	set_column_address	Set the column extent.	4	Yes	Yes	No
2Bh	set_page_address	Set the page extent.	4	Yes	Yes	No
2Ch	write_memory_start	Transfer image data from the Host Processor to the peripheral starting at the location provided by set_column_address and set_page_address.	Variable	Yes	Yes	No
2Dh	write_LUT	Fills the peripheral look-up table with the provided data.	Variable	optional	No	No
2Eh	read_memory_start	Transfer image data from the peripheral to the Host Processor interface starting at the location provided by set_column_address and set_page_address.	Variable	Yes	Yes	No
30h	set_partial_area	Defines the partial display area on the display device.	4	Yes	Yes	No
33h	set_scroll_area	Defines the vertical scrolling and fixed area on display device.	6	Yes	No	No
34h	set_tear_off	Synchronization information is not sent from the display module to the host processor.	0	Yes	No	No
35h	set_tear_on	Synchronization information is sent from the display module to the host processor at the start of VFP.	1	Yes	No	No

36h	set_address_mode	Set the read order from frame memory to the display panel.	1	Yes	Yes	Yes
37h	set_scroll_start	Defines the vertical scrolling starting point.	2	Yes	No	No
38h	exit_idle_mode	Full color depth is used on the display panel.	0	Yes	No	No
39h	enter_idle_mode	Reduced color depth is used on the display panel.	0	Yes	No	No
3Ah	set_pixel_format	Defines how many bits per pixel are used in the interface.	1	Yes	Yes	Yes
3Ch	write_memory_continue	Transfer image information from the Host Processor interface to the peripheral from the last written location.	Variable	Yes	Yes	No
3Eh	read_memory_continue	Read image data from the peripheral continuing after the last read_memory_continue or read_memory_start.	Variable	Yes	Yes	No
44h	set_tear_scanline	Synchronization information is sent from the display module to the host processor when the display device refresh reaches the provided scanline.	2	Yes	No	No
45h	get_scanline	Get the current scanline.	2	Yes	Yes	No
Dah	Read ID1					
DBh	Read ID2					
DCh	Read ID3					

Notes:

1. There will be no abnormal visible effects on the display when S/W or H/W Reset are applied.
2. After Powered-On Reset finishes within 10 μ s after both VDD & VDDI are applied.
3. Mode 1 means Tearing Effect Output Line consists of V-Blanking Information only.

For Command Descriptions, please see: <https://www.newhavendisplay.com/appnotes/datasheets/LCDs/ILI9163V.pdf>

Timing Characteristics

3-wire Serial Interface:

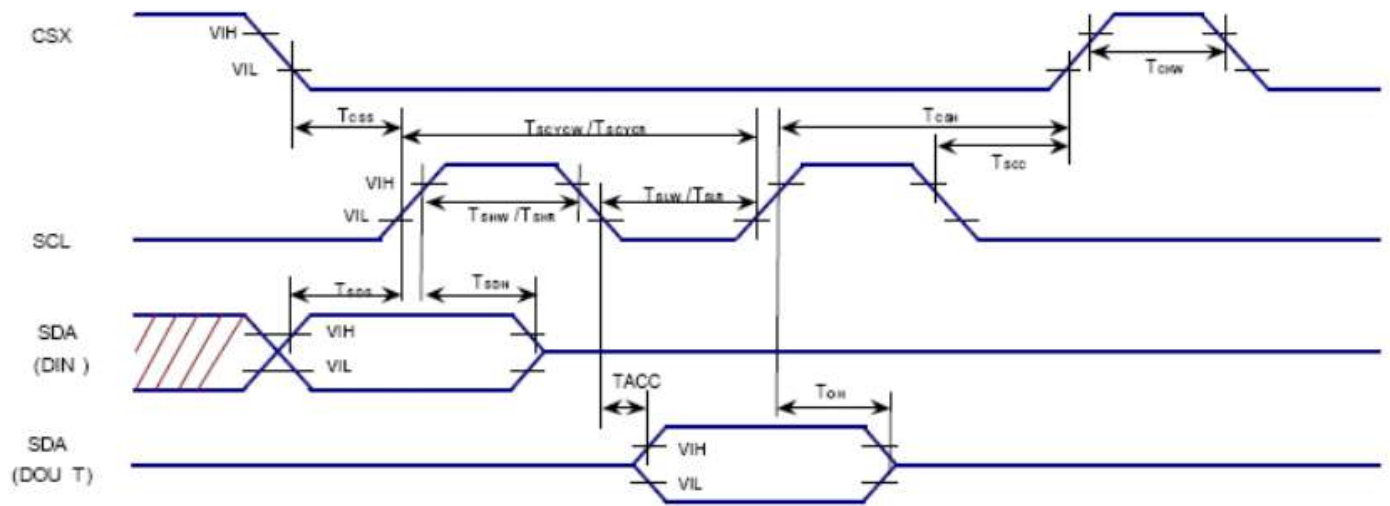

Signal	Symbol	Parameter	MIN	MAX	Unit	Description
CSX	TCSS	Chip select setup time	15		ns	
	TCSH	Chip select hold time	60		ns	
	TCHW	Chip select setup time	40		ns	
SCL	TSCYCW	Serial clock cycle(Write)	66		ns	
	TSHW	S"L""H" pulse width(Write)	1		ns	
	TSLW	S"L""L" pulse width(Write)	15		ns	
	TSCYCR	Serial clock cycle(Read)	150		ns	
	TSHR	S"L""H" pulse width(Read)	60		ns	
	TSLR	S"L""L" pulse width(Read)	60		ns	
SDA(DIN) (DOU T)	TSDS	Data setup time	10		ns	
	TSDH	Data hold time	10		ns	
	TACC	Access time	10	50	ns	For maximum CL = 30pF
	TOH	Output disable time	15		ns	For minimum CL = 8pF

Note 1: VDDI=1.65 to 3.3V, VDD=2.6 to 3.3V, AGND=GND=0V. Ta=-30 to 70°C (to +85°C no damage)

Note 2 : The input signal rise time and fall time(tr, tf) is specified at 15 ns or less.

Logic high and low levels are specified as 10% and 90% of VDDI for Input signals.

4-wire Serial Interface

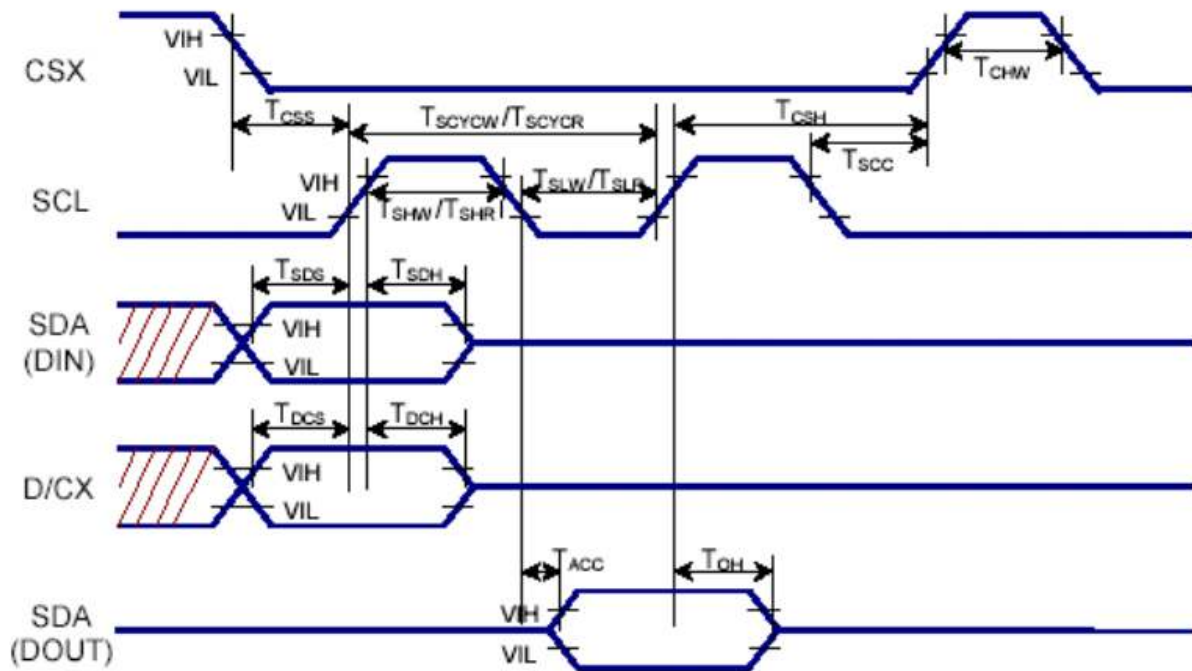

Signal	Symbol	Parameter	MIN	MAX	Unit	Description
CSX	T_{CSS}	Chip select setup time	15		ns	
	T_{CSH}	Chip select hold time	60		ns	
	T_{CHW}	Chip select setup time	40		ns	
SCL	T_{SCYCW}	Serial clock cycle(Write)	66		ns	
	T_{SHW}	$S^L \rightarrow H$ pulse width(Write)	1		ns	
	T_{SLW}	$S^L \rightarrow L$ pulse width(Write)	15		ns	
	T_{SCYCR}	Serial clock cycle(Read)	150		ns	
	T_{SHR}	$S^L \rightarrow H$ pulse width(Read)	60		ns	
	T_{SLR}	$S^L \rightarrow L$ pulse width(Read)	60		ns	
D/CX	T_{DCS}	D/CX setup time	7		ns	
	T_{DCH}	D/CX hold time	7		ns	
SDA(DIN) (DOUT)	T_{SDS}	Data setup time	10		ns	
	T_{SDH}	Data hold time	10		ns	
	T_{ACC}	Access time	10	50	ns	For maximum $CL = 30pF$
	T_{OH}	Output disable time	15		ns	For minimum $CL = 8pF$

Note 1: $V_{DDI}=1.65$ to $3.3V$, $V_{DD}=2.6$ to $3.3V$, $AGND=GND=0V$. $T_a=-30$ to $70^\circ C$ (to $+85^\circ C$ no damage)

Note 2 : The input signal rise time and fall time(t_r , t_f) is specified at 15 ns or less.

Logic high and low levels are specified as 10% and 90% of V_{DDI} for Input signals.

Reset Timing

Item	Symbol	Unit	Min.	Typ.	Max.
Reset low-level width	t_{RES}	ms	1	-	-
Reset rise time	t_{rRES}	μ s	-	-	10

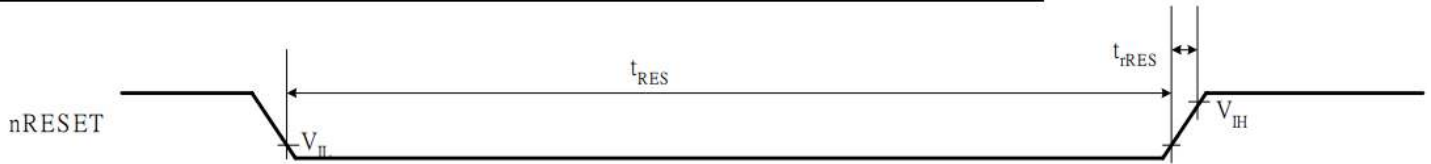

Power ON/OFF Sequence

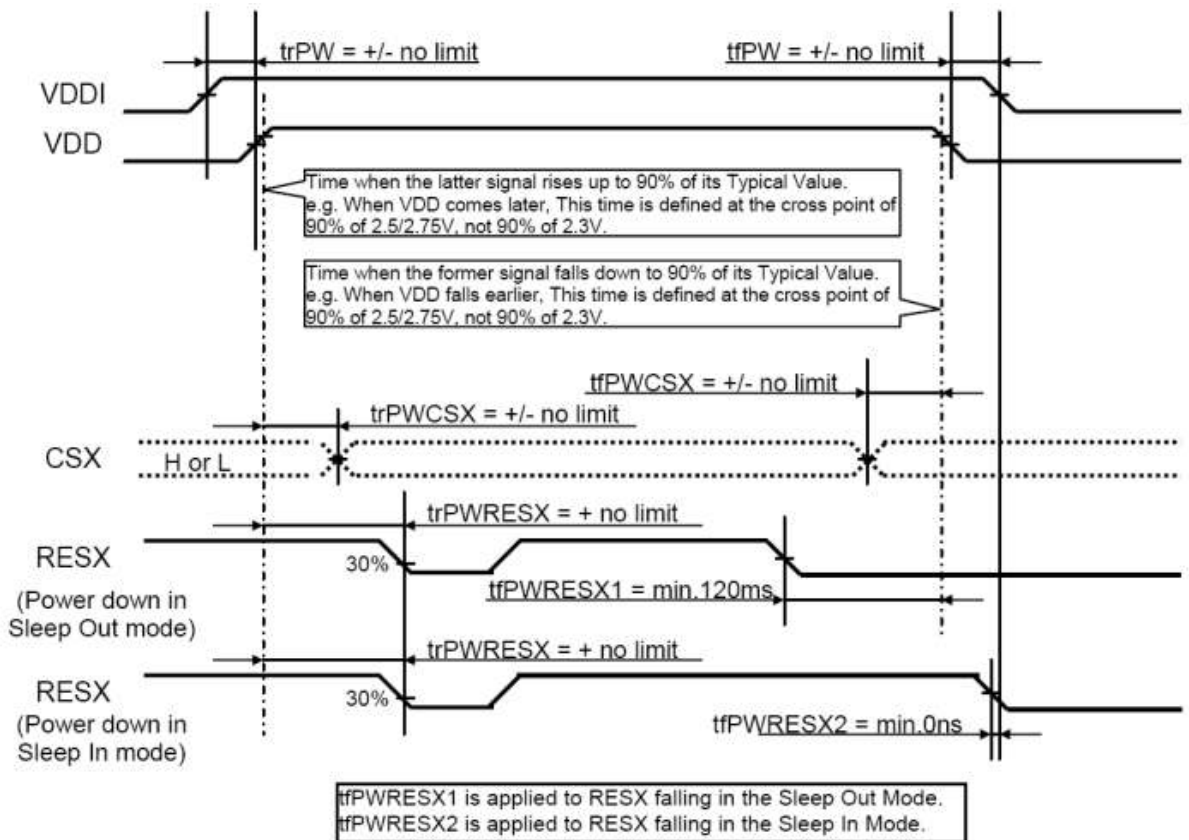

Note: Unless otherwise specified, timings herein show cross point at 50% of signal/power level.

Example Program Code

```
*****/
*      Initialization and Setup Routine for 3-Line & 4-Line      *
*****/
```

```
void setup()
{
  DDRB = 0xFF;           //Enable All outputs on PortB
  PORTB = 0x00;
  DDRD = 0xFF;           //Enable All outputs on PortD
  PORTD = 0x00;
  DDRD |= (1<<DDD6);     //SDIO = 1
  DDRD |= (1<<DDD7);     //SCL = 1
  digitalWrite(RST, LOW);
  delay(150);
  digitalWrite(RST, HIGH);
  delay(150);
  command(0x11);         //exit SLEEP mode
  delay(100);
  command(0x28);         //display off
  command(0x26);         //select gamma curve
  data(0x04);

  command(0xB1);         //frame rate control
  data(0x0A);
  data(0x14);

  command(0xC0);         //power control 1
  data(0x0A);
  data(0x00);

  command(0xC1);         //power control 2
  data(0x02);

  command(0xC5);         //VCOM control 1
  data(0x2F);
  data(0x3E);

  command(0xC7);         //VCOM control 2
  data(0x40);

  command(0x2A);         //column address set
  data(0x00);

  data(0x00);           //start 0x0000
  data(0x00);

  data(0x7F);           //end 0x007F
  command(0x2B);         //page address set
  data(0x00);
  data(0x00);           //start 0x0000
  data(0x00);
  data(0x9F);           //end 0x009F

  command(0x36);         //memory access control
  data(0xC0);           //C0 = RGB; C8 = BGR
  command(0x3A);         //pixel format = 18 bit per pixel
  data(0x06);

  command(0x29);         //display ON
  delay(10);
}
```

3-line Serial Interface

```
/******  
*           Functions           *  
*****/  
  
void command(unsigned char c) //9-bit Transmission  
{  
    digitalWrite(CS, LOW);           ///CS = 0  
    PORTD &= ~(1<<PORTD6);          //SDIO = 0 (Set D/C bit LOW for Command)  
    PORTD &= ~(1<<PORTD7);          //SCL = 0  
    PORTD |= (1<<PORTD7);           //SCL = 1  
    PORTD &= ~(1<<PORTD7);          //SCL = 0  
    for (int i=0;i<8;i++)  
    {  
        if((c & 0x80)== 0x80)        //Send MSB  
            PORTD |= (1<<PORTD6);    //SDIO = 1  
        else  
            PORTD &= ~(1<<PORTD6);    //SDIO = 0  
        c = (c<<1);  
        PORTD &= ~(1<<PORTD7);        //SCL = 0  
        PORTD |= (1<<PORTD7);         //SCL = 1  
        PORTD &= ~(1<<PORTD7);        //SCL = 0  
    }  
    digitalWrite(CS, HIGH);          ///CS = 1  
}
```

```
void data(unsigned char d) //9-bit Transmission  
{  
    digitalWrite(CS, LOW);           ///CS = 0  
    PORTD |= (1<<PORTD6);            //SDIO = 1 (Set D/C bit HIGH for Data)  
    PORTD &= ~(1<<PORTD7);          //SCL = 0  
    PORTD |= (1<<PORTD7);           //SCL = 1  
    PORTD &= ~(1<<PORTD7);          //SCL = 0  
    for (int i=0;i<8;i++)  
    {  
        if((d & 0x80)== 0x80)        //Send MSB  
            PORTD |= (1<<PORTD6);    //SDIO = 1  
        else  
            PORTD &= ~(1<<PORTD6);    //SDIO = 0  
        d = (d<<1);  
        PORTD &= ~(1<<PORTD7);        //SCL = 0  
        PORTD |= (1<<PORTD7);         //SCL = 1  
        PORTD &= ~(1<<PORTD7);        //SCL = 0  
    }  
    digitalWrite(CS, HIGH);          ///CS = 1  
}
```

4-line Serial Interface

```
/******  
*           Functions           *  
*****/
```

```
void command(unsigned char c) //8-bit Transmission  
{  
    digitalWrite(CS, LOW);           ///CS = 0  
    digitalWrite(DC, LOW);          //D/C = 0  
    for (int i=0;i<8;i++)  
    {  
        if((c & 0x80)== 0x80)        //Send MSB  
            PORTD |= (1<<PORTD6);    //SDIO = 1  
        else  
            PORTD &= ~(1<<PORTD6);    //SDIO = 0  
        c = (c<<1);  
        PORTD &= ~(1<<PORTD7);        //SCL = 0  
        PORTD |= (1<<PORTD7);         //SCL = 1  
        PORTD &= ~(1<<PORTD7);        //SCL = 0  
    }  
    digitalWrite(CS, HIGH);          ///CS = 1  
}
```

```
void data(unsigned char d) //8-bit Transmission  
{  
    digitalWrite(CS, LOW);           ///CS = 0  
    digitalWrite(DC, HIGH);          //D/C = 1  
    for (int i=0;i<8;i++)  
    {  
        if((d & 0x80)== 0x80)        //Send MSB  
            PORTD |= (1<<PORTD6);    //SDIO = 1  
        else  
            PORTD &= ~(1<<PORTD6);    //SDIO = 0  
        d = (d<<1);  
        PORTD &= ~(1<<PORTD7);        //SCL = 0  
        PORTD |= (1<<PORTD7);         //SCL = 1  
        PORTD &= ~(1<<PORTD7);        //SCL = 0  
    }  
    digitalWrite(CS, HIGH);          ///CS = 1  
}
```

Quality Information

Test Item	Content of Test	Test Condition	Note
High Temperature storage	Endurance test applying the high storage temperature for a long time.	+80°C , 96hrs	2
Low Temperature storage	Endurance test applying the low storage temperature for a long time.	-30°C , 96hrs	1,2
High Temperature Operation	Endurance test applying the electric stress (voltage & current) and the high thermal stress for a long time.	+70°C , 96hrs	2
Low Temperature Operation	Endurance test applying the electric stress (voltage & current) and the low thermal stress for a long time.	-20°C , 96hrs	1,2
High Temperature / Humidity Storage	Endurance test applying the electric stress (voltage & current) and the high thermal with high humidity stress for a long time.	+50°C , 90% RH , 96hrs	1,2
Thermal Shock resistance	Endurance test applying the electric stress (voltage & current) during a cycle of low and high thermal stress.	-20°C,60min -> 70°C,60min = 1 cycle, 20 cycles.	
Vibration test	Endurance test applying vibration to simulate transportation and use.	10-50Hz , 5G amplitude. 30min in each of 3 directions X, Y, Z	3
Static electricity test	Endurance test applying electric static discharge.	Air: ±8kV 150pF/330Ω, 5 Times	
		Contact: ±4kV 150pF/330Ω, 5 Times	

Note 1: No condensation to be observed.

Note 2: Conducted after 4 hours of storage at 25°C, 0%RH.

Note 3: Test performed on product itself, not inside a container.

Precautions for using LCDs/LCMs

See Precautions at www.newhavendisplay.com/specs/precautions.pdf

Warranty Information

See Terms & Conditions at http://www.newhavendisplay.com/index.php?main_page=terms